

# Installation manual

## Tumble dryer

TE1220E, TE1220G



**Electrolux**  
PROFESSIONAL



# Contents

---

## Contents

1	Safety Precautions .....	5
1.1	Gas heated tumble dryer: .....	7
1.2	General safety information.....	7
1.3	Commercial use only.....	7
1.4	Copyright .....	7
1.5	Symbols.....	8
2	Warranty terms and exclusions.....	9
3	Technical data .....	10
3.1	Drawing .....	10
3.2	Technical data .....	11
3.3	Connections .....	11
4	Setup .....	12
4.1	Unpacking.....	12
4.2	Recycling instruction for packaging .....	13
4.3	Siting .....	14
4.4	Mechanical installation .....	15
5	Reversing the door .....	16
6	Evacuation system .....	18
6.1	Air principle .....	18
6.2	Fresh air.....	18
6.3	Exhaust duct .....	19
6.4	Shared exhaust duct .....	19
6.5	Exhaust dimensioning .....	20
6.6	Outside Ductwork Protection.....	21
7	Electrical connection.....	22
7.1	Electrical installation .....	22
7.2	Single-phase connection .....	23
7.3	Electrical connections .....	23
7.4	Install the Electronic Coin Meter (Coin Operated Models).....	24
8	Gas connection .....	26
8.1	Fasten the label .....	26
8.2	General.....	26
8.3	Connect the dryer to the gas supply.....	27
8.4	Gas installation .....	27
8.5	Table of pressure .....	28
8.6	Test run.....	28
8.7	Converting instructions.....	28
8.8	Data label.....	33
9	Coin meter operation .....	34
9.1	Price Programming & Drying Time Program Setup .....	34
9.2	Free Dry / OPL Mode .....	35
9.3	Price and Time Registers.....	35
9.3.1	Time for Amount to Start .....	35
9.3.2	Time Per Coin (or Push In Free Dry Mode) .....	35
9.4	Promotion programming (for extra drying time).....	35
9.5	Promotion via the real time clock (RTC).....	36
9.6	Promotion via external clock-driven relay or switch .....	36
10	Function check.....	37
11	CPU reset.....	37
12	Disposal information .....	38
12.1	Disposal of appliance at end of life .....	38
12.2	Disposal of packing.....	38

The manufacturer reserves the right to make changes to design and component specifications.



## 1 Safety Precautions

- Servicing shall be carried out only by authorized personnel.
- Only authorized spare parts, accessories and consumables shall be used.
- The machine is not to be used if industrial chemicals have been used for cleaning.
- Do not dry unwashed items in the machine.
- Items that have been soiled with substances such as cooking oil, acetone, alcohol, petrol, kerosene, spot removers, turpentine, waxes and wax removers should be washed in hot water with an extra amount of detergent before being dried in the machine.
- Items such as foam rubber (latex foam), shower caps, waterproof textiles, rubber backed articles and clothes or pillows fitted with foam rubber pads should not be dried in the machine.
- Fabric softeners or similar products should be used as specified by the fabric softener instructions.
- The final part of a drying cycle occurs without heat (cool down cycle) to ensure that the items are left at a temperature that ensures that the items will not be damaged.
- Remove all objects from pockets such as lighters and matches.
- **WARNING.** Never stop the machine before the end of the drying cycle unless all items are quickly removed and spread out so that the heat is dissipated.
- Adequate ventilation has to be provided to avoid the back flow of gases into the room for appliances burning other fuels, including open fires.
- Exhaust air must not be discharged into a flue which is used for exhausting fumes from appliances burning gas or other fuels.
- The machine must not be installed behind a lockable door, a sliding door or a door with a hinge on the opposite side to that of the machine in such a way that a full opening of the machine is restricted.
- If the machine has a lint trap this has to be cleaned frequently.
- The lint must not be accumulated around the machine.
- **DO NOT MODIFY THIS APPLIANCE.**
- When performing service or replacing parts, the power must be disconnected.
- When the power is disconnected, the operator must see that the machine is disconnected (that the plug is removed and remains removed) from any point to which he has access. If this is not possible, due to the construction or installation of the machine, a disconnection with a locking system in the isolated position shall be provided.
- In accordance with the wiring rules: mount a multi-pole switch prior to the machine to facilitate installation and service operations.
- **WARNING:** The appliance must not be supplied through an external switching device, such as a timer, or connected to a circuit that is regularly switched on and off by a utility.
- If different rated voltages or different rated frequencies (separated by a /) are stated at the machine data plate, instructions for adjusting the appliance for operation at the required rated voltage or rated frequency are stated in the installation manual.
- Stationary appliances not fitted with means for disconnection from the supply mains having a contact separation in all poles that provide full disconnection under overvoltage category III, the instructions state that means for disconnection must be incorporated in the fixed wiring in accordance with the wiring rules.
- The openings in the base, shall not be obstructed by a carpet.

- Oil-affected items can ignite spontaneously, especially when exposed to heat sources such as in a tumble dryer. The items become warm, causing an oxidation reaction in the oil. Oxidation creates heat. If the heat cannot escape, the items can become hot enough to catch fire. Piling, stacking or storing oil-affected items can prevent heat from escaping and so create a fire hazard.
- If it is unavoidable that fabrics that contain vegetable or cooking oil or have been contaminated by hair care products be placed in a tumble dryer they should first be washed in hot water with extra detergent – this will reduce, but not eliminate, the hazard.
- Maximum mass of dry cloth: 12 kg.
- A-weighted emission sound pressure level at working stations: <68 dB(A).
- If the supply cord is damaged, it must be replaced by the manufacturer, its service agent or similarly qualified persons in order to avoid a hazard.

### 1.1 Gas heated tumble dryer:

- Before installation, check that the local distribution conditions, nature of gas and pressure and the adjustment of the appliance are compatible.
- The machine is not to be installed in rooms containing cleaning machines with perchloroethylene, TRICHLOROETHYLENE or CHLOROFLUOROCONTAINING HYDROCARBONS as cleaning agents.
- If you can smell gas:
  - Do not switch on any equipment
  - Do not use electrical switches
  - Do not use telephones in the building
  - Evacuate the room, building or area
  - Contact the person responsible for the machine
- Additional requirements for the following countries; AT, BE, BG, HR, CY, CZ, DK, EE, FI, FR, DE, GR, HU, IS, IE, IT, LV, LT, LU, MT, NL, NO, PL, PT, RO, SK, SI, ES, SE, CH, TR, UK:
  - The appliance can be used in public areas.
  - This appliance can be used by children aged from 8 years and above and persons with reduced physical, sensory or mental capabilities or lack of experience and knowledge if they have been given supervision or instruction concerning use of the appliance in a safe way and understand the hazards involved. Children shall not play with the appliance. Cleaning and user maintenance shall not be made by children without supervision.
- Additional requirements for other countries:
  - This appliance is not intended for use by persons (including children) with reduced physical, sensory or mental capabilities, or lack of experience and knowledge, unless they have been given supervision or instruction concerning use of the appliance by a person responsible for their safety. Children should be supervised to ensure that they do not play with the appliance.

### 1.2 General safety information

In order to prevent damage to the electronics (and other parts) that may occur as the result of condensation, the machine should be placed in room temperature for 24 hours before being used for the first time.





### 1.3 Commercial use only

The machine/machines covered by this manual is/are made for commercial and industrial use only.

### 1.4 Copyright

This manual is intended solely for consultation by the operator and can only be given to third parties with the permission of Electrolux Professional company.

**1.5 Symbols**

	Caution
	Caution, hot surface
	Caution, high voltage
	Read the instructions before using the machine



## 2 Warranty terms and exclusions

If the purchase of this product includes warranty coverage, warranty is provided in line with local regulations and subject to the product being installed and used for the purposes as designed, and as described within the appropriate equipment documentation.

Warranty will be applicable where the customer has used only genuine spare parts and has performed maintenance in accordance with Electrolux Professional user and maintenance documentation made available in paper or electronic format.

Electrolux Professional strongly recommends using Electrolux Professional approved cleaning, rinse and descaling agents to obtain optimal results and maintain product efficiency over time.

The Electrolux Professional warranty does not cover:

- service trips cost to deliver and pick up the product;
- installation;
- training on how to use/operate;
- replacement (and/or supply) of wear and tear parts unless resulting from defects in materials or workmanship reported within one (1) week from the failure;
- correction of external wiring;
- correction of unauthorized repairs as well as any damages, failures and inefficiencies caused by and/or resulting from;
  - insufficient and/or abnormal capacity of the electrical systems (current/voltage/frequency, including spikes and/or outages);
  - inadequate or interrupted water supply, steam, air, gas (including impurities and/or other that does not comply with the technical requirements for each appliance);
  - plumbing parts, components or consumable cleaning products that are not approved by the manufacturer;
  - customer's negligence, misuse, abuse and/or non-compliance with the use and care instructions detailed within the appropriate equipment documentation;
  - improper or poor: installation, repair, maintenance (including tampering, modifications and repairs carried out by third parties not authorized third parties) and modification of safety systems;
  - Use of non-original components (e.g.: consumables, wear and tear, or spare parts);
  - environment conditions provoking thermal (e.g. overheating/freezing) or chemical (e.g. corrosion/oxidation) stress;
  - foreign objects placed in- or connected to- the product;
  - accidents or force majeure;
  - transportation and handling, including scratches, dents, chips, and/or other damage to the finish of the product, unless such damage results from defects in materials or workmanship and is reported within one (1) week of delivery unless otherwise agreed;
- product with original serial numbers that have been removed, altered or cannot be readily determined;
- replacement of light bulbs, filters or any consumable parts;
- any accessories and software not approved or specified by Electrolux Professional.

Warranty does not include scheduled maintenance activities (including the parts required for it) or the supply of cleaning agents unless specifically covered within any local agreement, subject to local terms and conditions.

Check on Electrolux Professional website the list of authorized customer care.

### 3 Technical data

#### 3.1 Drawing

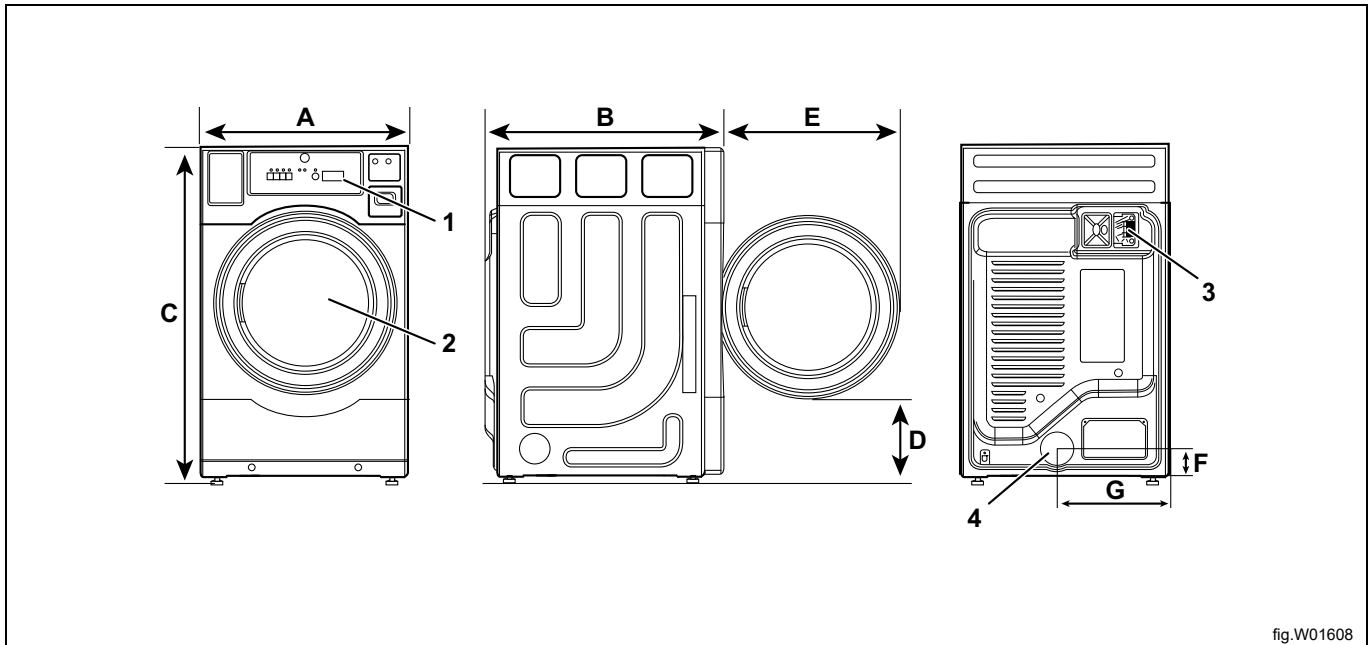

fig.W01608

1	Operating panel
2	Door opening, $\varnothing$ 570 mm
3	Electrical connection
4	Exhaust connection

	A	B	C	D	E	F	G
mm	686	822	1098	302	555	91	368

#### Footprint

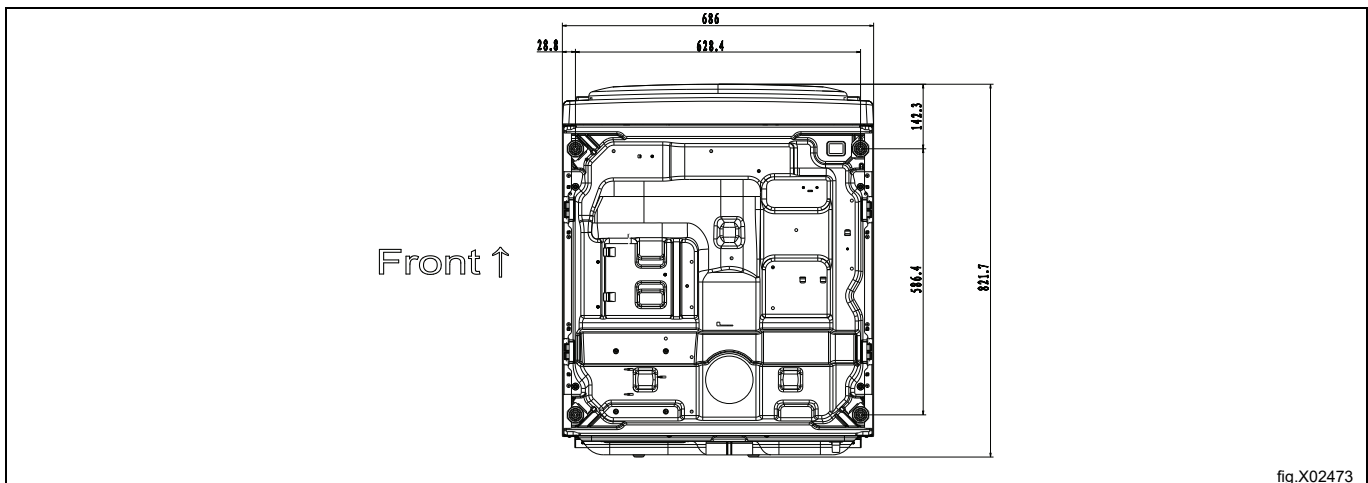

fig.X02473

### 3.2 Technical data

Net Weight ( electric heating )	kg	70
Net Weight ( Gas heating )	kg	78
Drum volume	litres	218
Drum diameter	mm	664
Drum depth	mm	533
Drum speed, medium load	rpm	45
Rated capacity, filling factor 1:18 (Max. load)	kg	12
Heating: Electricity ( 230V )	kW	4.84
Nominal Heat Input ( Gas dryer )	kW	5.7
Maximum air flow	m <sup>3</sup> /h	256
Maximum static back pressure	Pa	130
A-weighted emission sound pressure level at working stations	dB(A)	68
Gas rate(Hi):G20	m <sup>3</sup> /h	0.6
Gas rate(Hi):G30	m <sup>3</sup> /h	0.17
Gas rate(Hi):G31	m <sup>3</sup> /h	0.23

### 3.3 Connections

Air outlet ( Electric heating )	∅ mm	100
Air outlet ( Gas heating )	∅ mm	102
Gas connection	1/2"	ISO 7/1-R1/2

#### Note!

It is pointed out that the connection and commissioning of appliances complying with this standard are subject to observance of the installation regulations in force in the countries where these appliances are marketed.

## 4 Setup

### 4.1 Unpacking

**Note!**

**Two persons are recommended for the unpacking.**

The machine is delivered fixed onto the transport pallet with packing strap.

Remove packing strap from the machine then remove the transport pallet.

Remove all the packing from the machine.

**Note!**

**When moving the machine, handle it with care. The drum has no transport clamps.**

**Place the machine on its final position.**

4.2 Recycling instruction for packaging

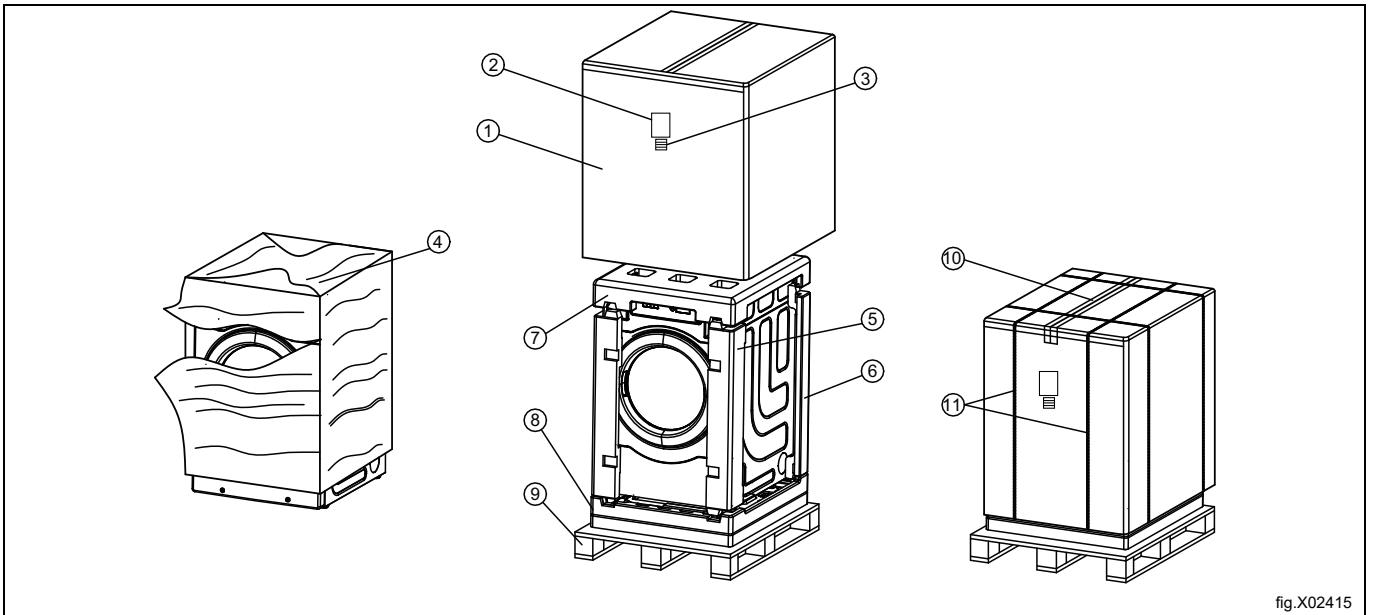

fig.X02415

Fig.	Description	Code	Type
1	Cardboard packaging	PAP 20	Paper
2	Packaging box sticker	PAP 22	Paper
3	Bar code sticker	PAP 22	Paper
4	Wrapping film	HDPE 2	Plastics
5	Front corner protection	PS 6	Plastics
6	Back corner protection	PS 6	Plastics
7	Top protection	PS 6	Plastics
8	Bottom protection	C/* 81	Combination
9	Pallet	FOR 50	Wood
10	PET tape	PET 1	Plastics
11	Packaging strap	PP 5	Plastics

### 4.3 Siting

The machine should be positioned so that there is plenty of room for working, both for the user and service personnel. The following clearances are recommended:

- The requirement to allow the door to open completely is 36 inches (91 cm).
- A minimum overhead clearance of 6-inches (15.24 cm) is recommended.
- Dryer should be positioned a minimum of 12-inches (30.5 cm) away from the nearest obstruction, 24-inches (61 cm) is recommended for ease of installation, maintenance, and service.

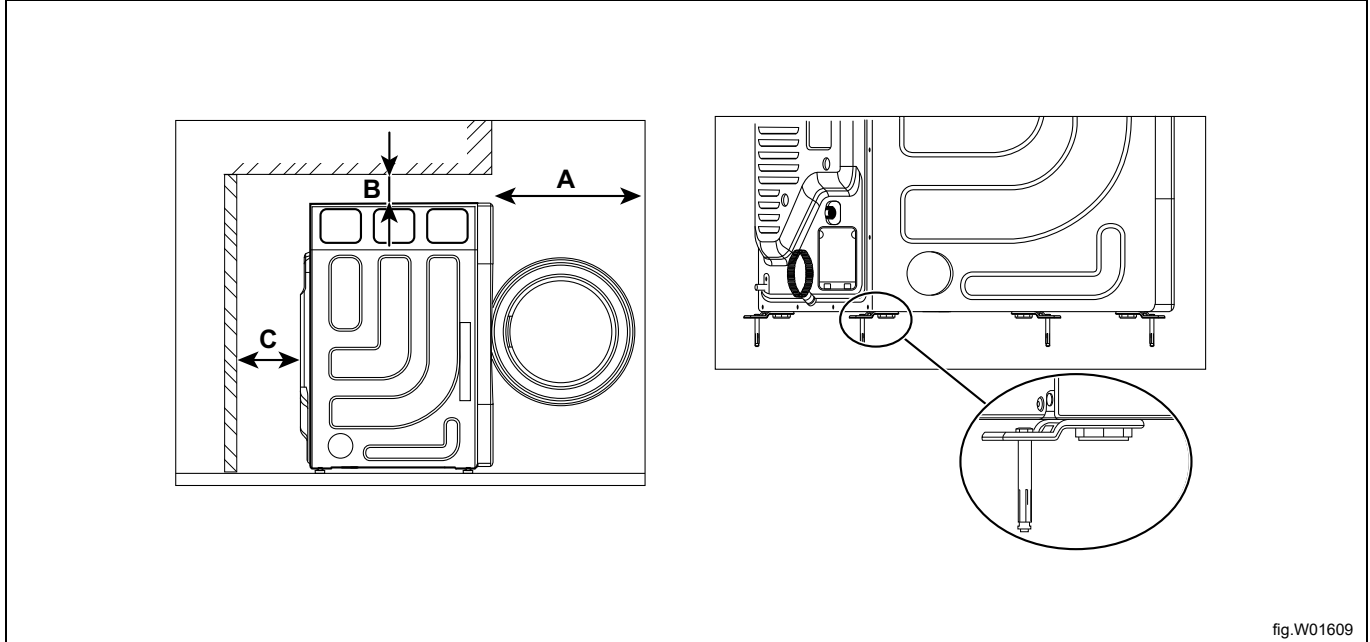

fig.W01609

A	Min. 36 inch (91 cm)
B	Min. 6 inch (15.24 cm)
C	Min. 12 inch (30.5 cm)

#### 4.4 Mechanical installation

Level the machine with the feet of the machine. The maximum height adjustment of the feet is 15 mm.

It is important to lock the feet with nuts (A).

For the gas dryer, the four feet should be locked with the expansion bolts and foot press plates in the accessory bag to prevent straining of the gas supply when the appliance is moved, at least the two diagonal feet should be fixed.

See the top right illustration. If the installation conditions are not suitable for the use of expansion bolts, it is also possible to use a rope to straighten the machine onto the fixed pile on the wall.

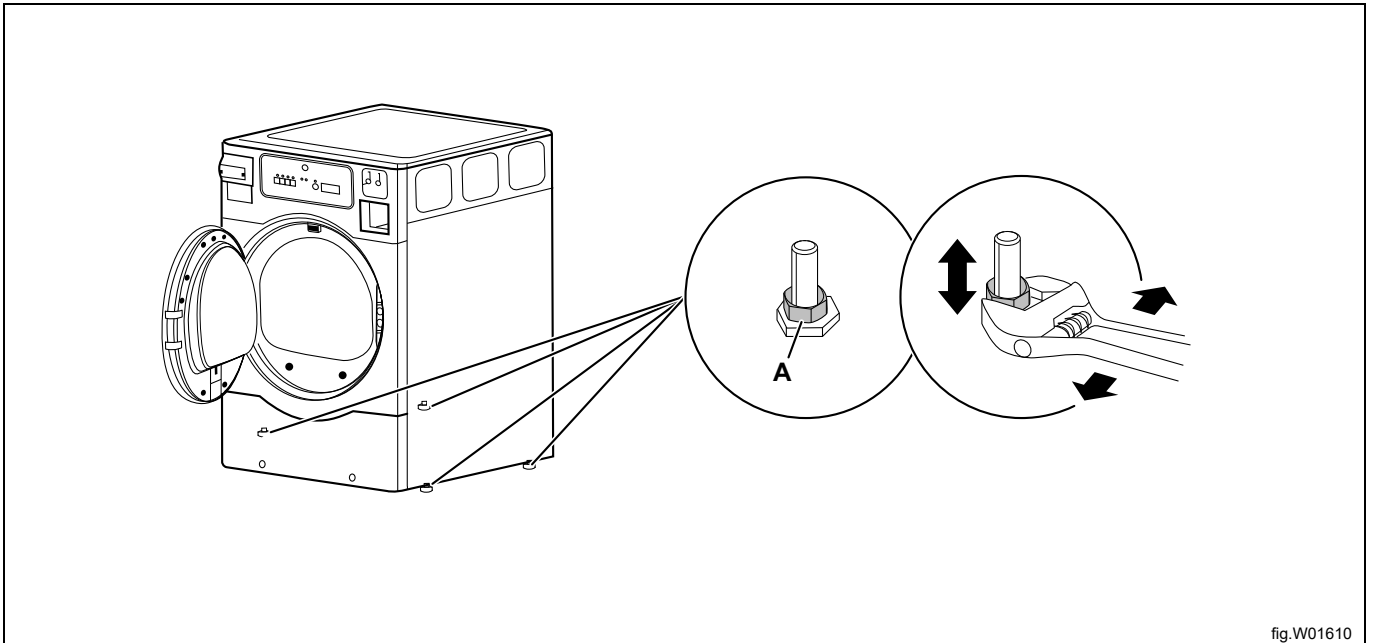
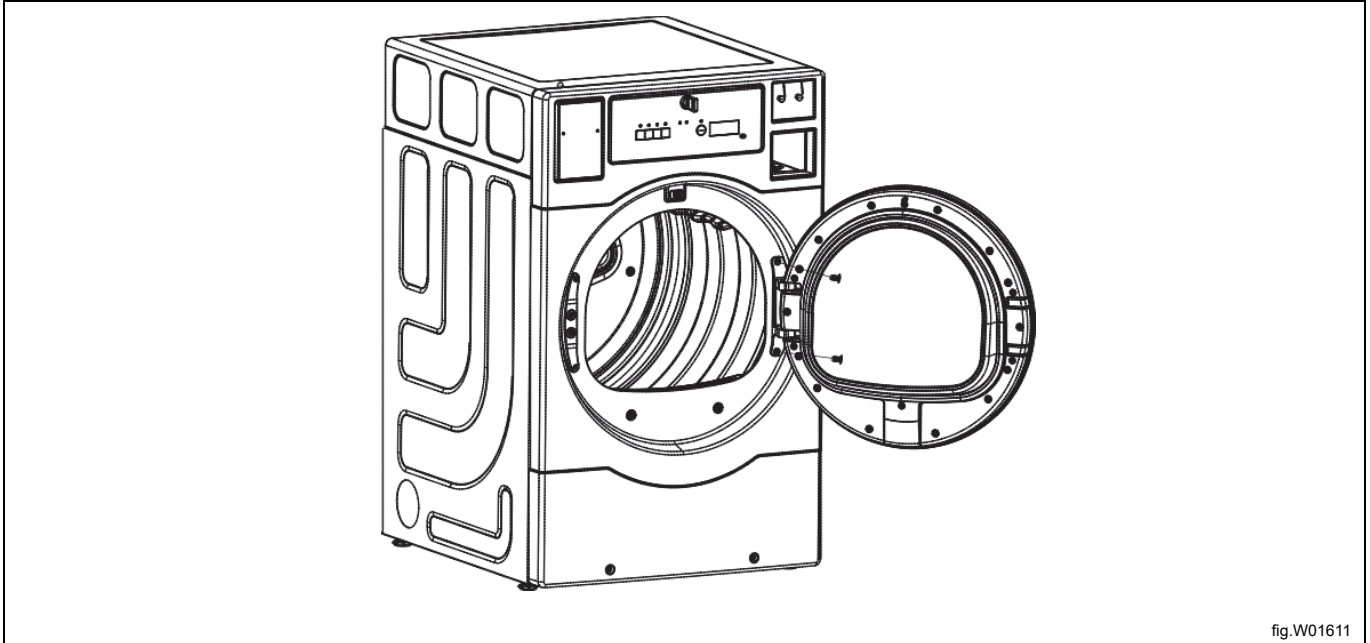

fig.W01610

## 5 Reversing the door

Disconnect the power to the machine.

Demount the hinge and remove the door.



Demount the screws on the door module except for (A) and (B). Rotate back door plate parts (C) and the middle frame (D) by 180 degrees. Remount the screws on the door module.

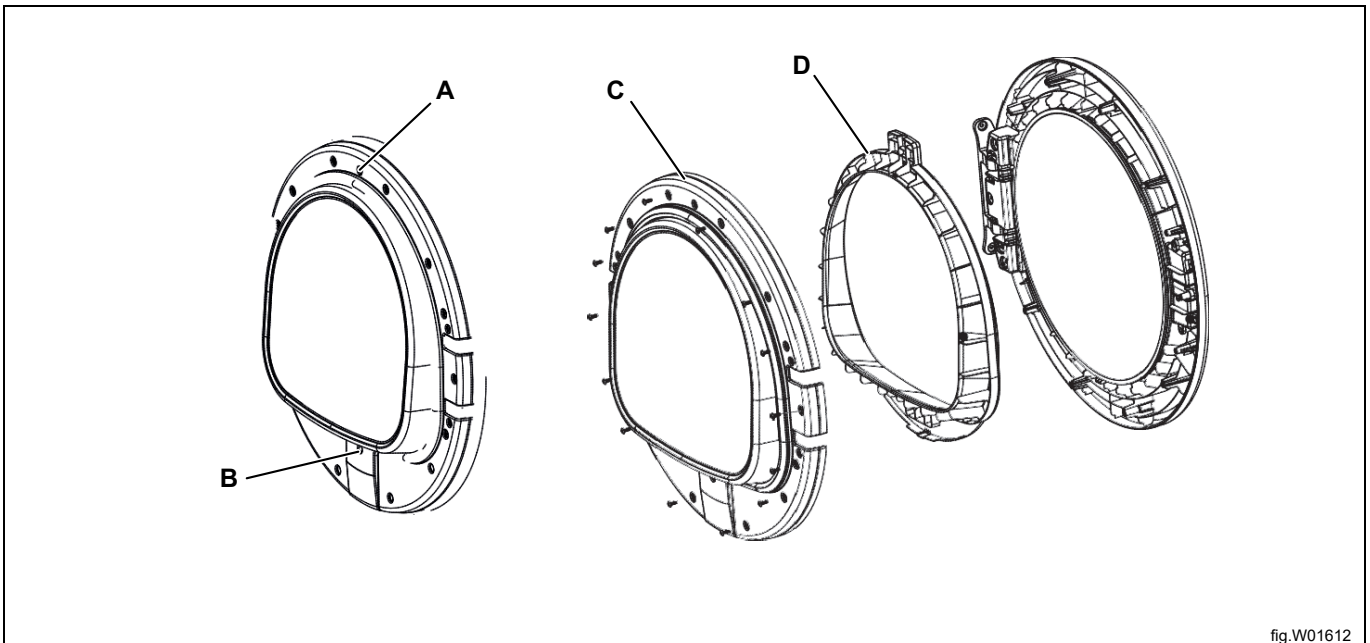



Demount the two magnets (A) and the protective cover (B) and move them to the opposite side.

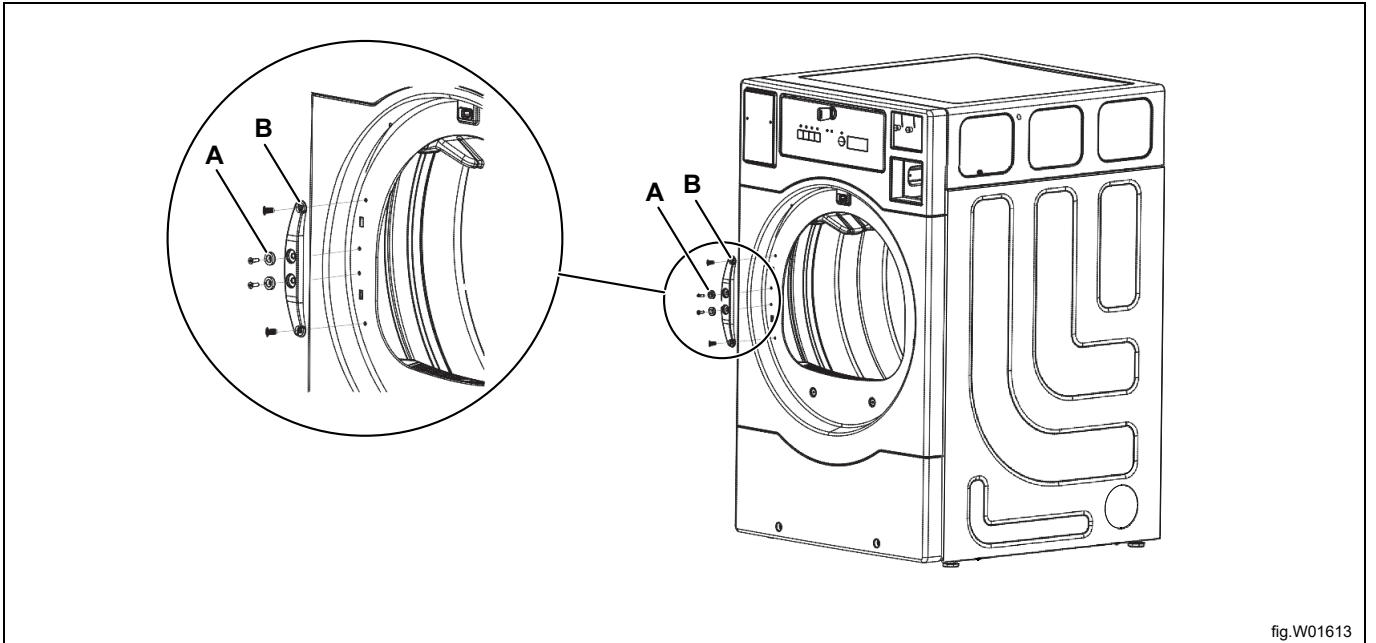

fig.W01613

Remount the two magnets (A) and the protective cover (B).  
Remount the door on the opposite side and fasten the hinges.

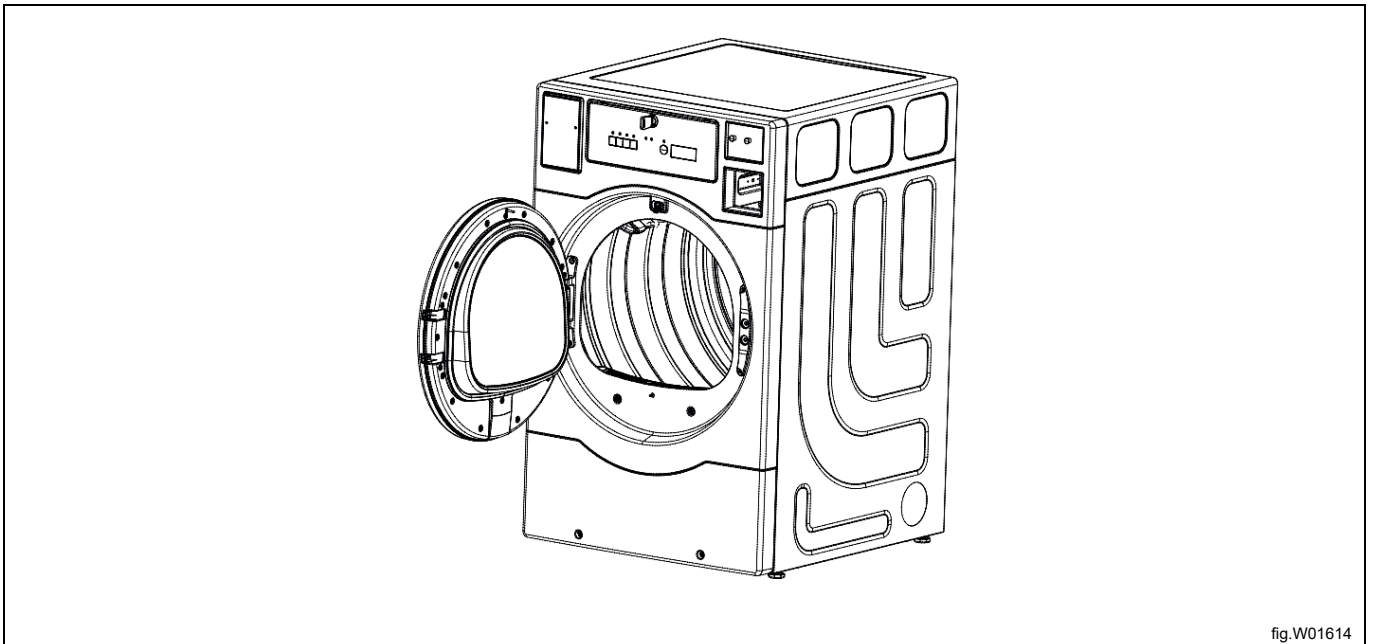

fig.W01614

Connect the power to the machine.  
Test run the machine.

## 6 Evacuation system

### 6.1 Air principle

The fan creates low pressure in the machine, drawing air into the drum via the heating unit.

The heated air passes through the garments and the drum holes.

The air then flows out through a lint filter positioned below the drum. Then the air is evacuated through the fan and exhaust system.

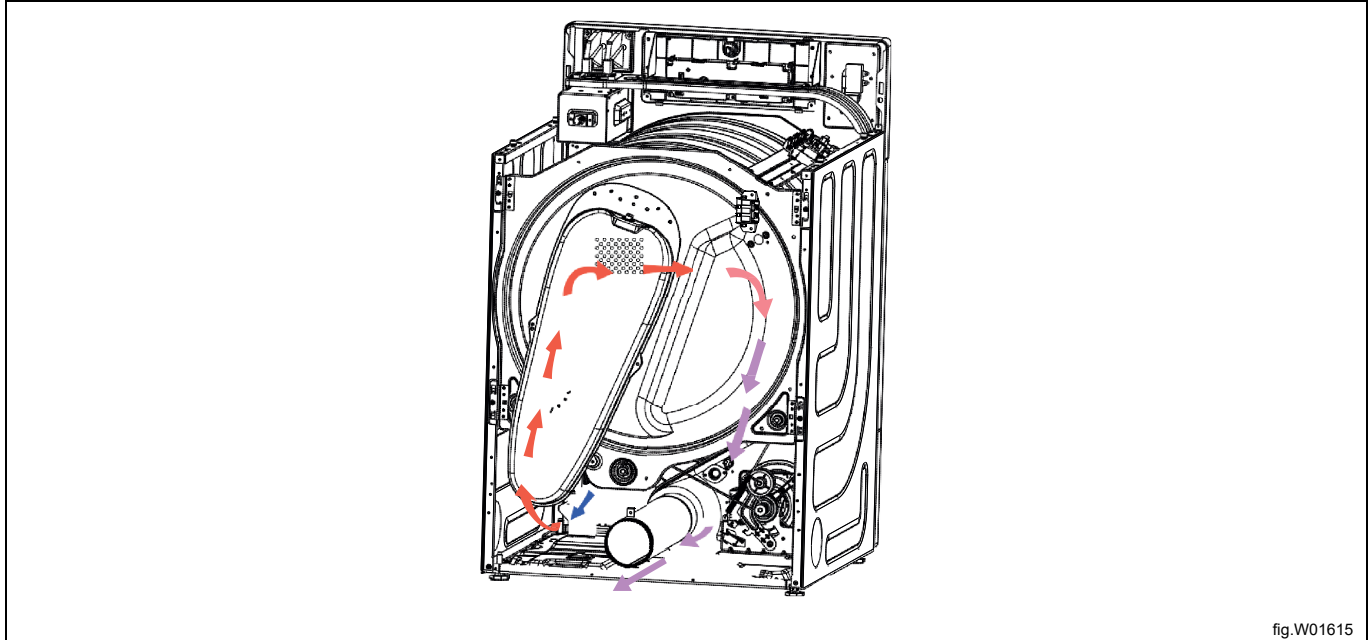

fig.W01615

#### Note!

It is very important that the machine gets enough fresh air in order to get the best drying result.

### 6.2 Fresh air

For maximum efficiency and the shortest possible drying time, it is important to ensure that fresh air is able to enter the room from the outside in the same volume as that blown out of the room.

To avoid draught in the room it is important to place the air inlet behind the machine.

The area of the air inlet opening is recommended to be five times the size of the exhaust pipe area. The area of the inlet opening is the area through which the air can flow without resistance from the grating/slatted cover.

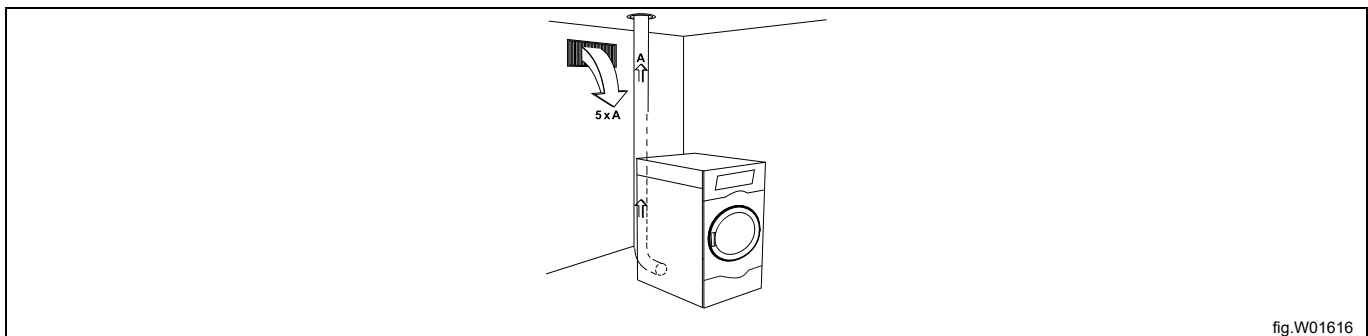

fig.W01616

#### Note!

Gratings/slatted covers often block half of the total fresh air vent area. Remember to take this into account.

### 6.3 Exhaust duct

- Only rigid or flexible metal duct should be used for exhausting.
- Plastic ducting is not to be used.
- Recommended material for exhaust is galvanized steel.
- The duct is not to be assembled with screws or other fastening means that extend into the duct and catch lint.
- The exhaust air should not be vented into a wall, a ceiling, or a concealed space of building.
- The exhaust duct must lead clear of the building as condensation may cause frost damage to the building.
- The exhaust duct must lead to the outdoors.
- The exhaust duct must be placed in such a way that it is protected on the outside.
- The exhaust duct must be smooth on the inside (low air resistance).
- The exhaust duct must have gentle bends.

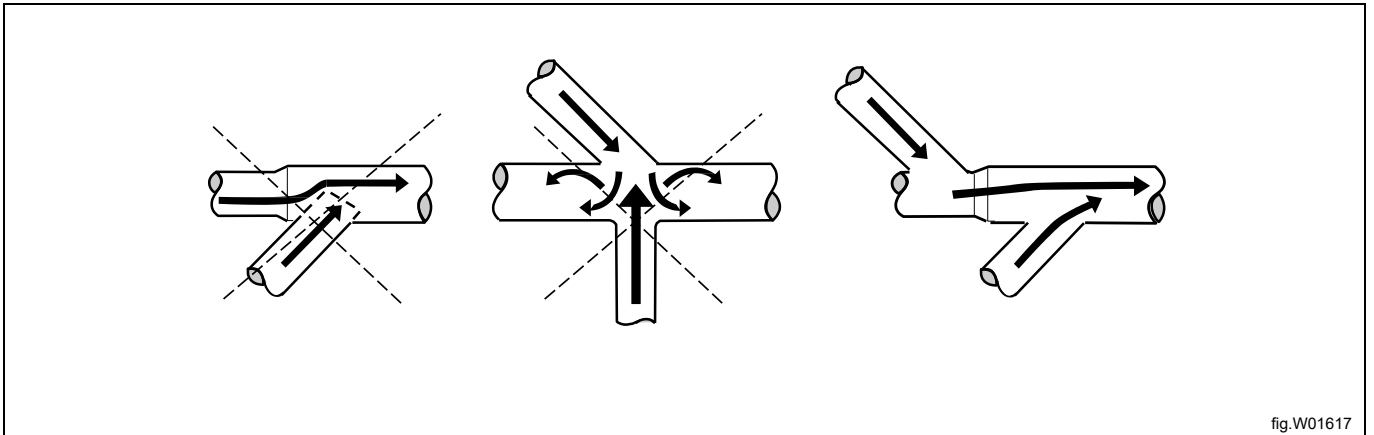

fig.W01617

### 6.4 Shared exhaust duct



It is recommended that each machine is connected to a separate exhaust duct and fully inserts into the exhaust duct.

When several machines shall use the same exhaust duct, the exhaust duct must increase after each machine.

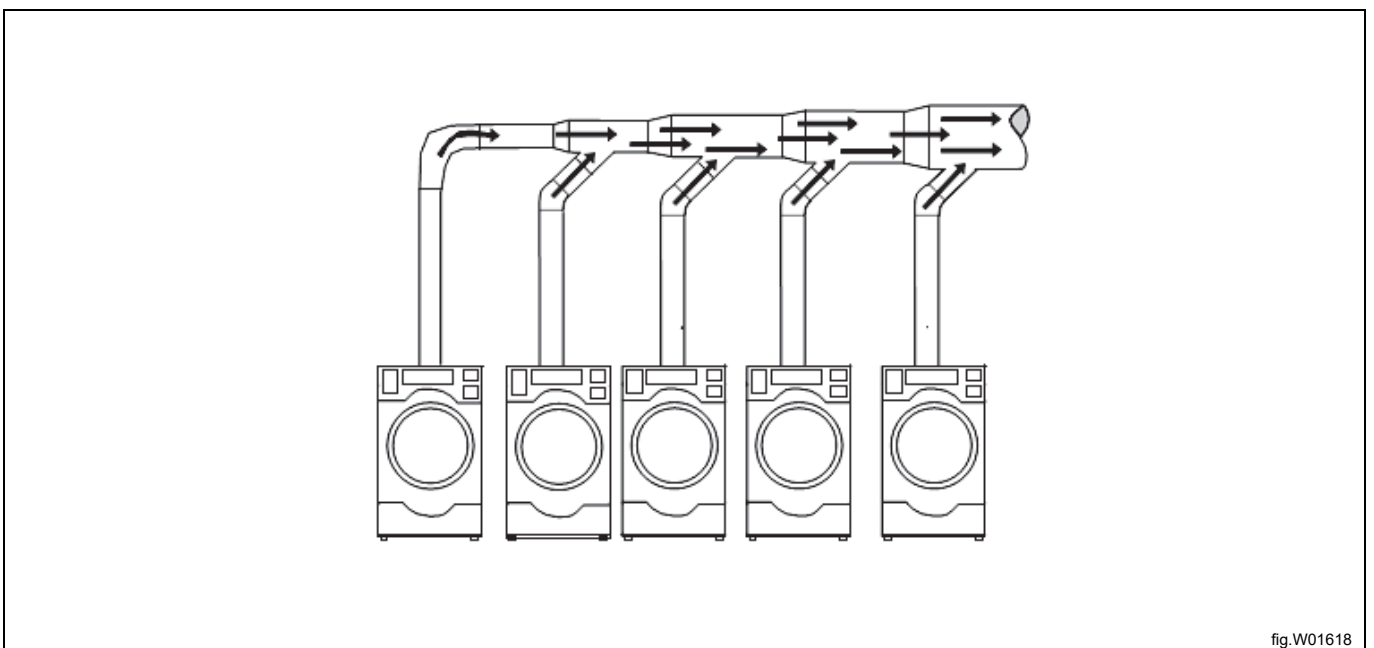

fig.W01618

Number of machines		1	2	3	4	5	6	7	8	9	10
Exhaust duct	ø mm	100	200	300	300	400	400	500	500	600	600
Recommended area of fresh air intake	m <sup>2</sup>	0.04	0.16	0.35	0.35	0.63	0.63	0.98	0.98	1.41	1.41
Minimum area of fresh air intake	m <sup>2</sup>	0.03	0.117	0.223	0.31	0.351	0.468	0.585	0.702	0.846	1.17



The exhaust duct diameter must not be reduced.  
The multiple dryers must have separate backdraft dampers when connected through a shared exhaust duct.  
If not, the load in the dryer will be affected by other dryers and become moist.

## 6.5 Exhaust dimensioning

It is important that the machine has correct air volume compared to each machines power. If the air flow is smaller or larger this will result in a longer drying period.

If the outlet pipe is long or the ventilation is not properly designed we recommend to clean the outlet pipes periodically. The exhaust pipes shall be short in order for the machine to work in the best way.

Failure to install back draft dampers in shared dryer exhaust ducts can cause hazardous conditions such backflow of combustible gases. Single or independent dryer venting is recommended. It is suggested that the use of 90° turns be avoided; use 30° and/or 45° bends.

It is recommended that exhaust or booster fans not be used in the exhaust ductwork system. If an exhaust booster fan is required, care must be taken to meet all other installation requirements.

The exhaust duct must be designed the static back pressure measured from the exhaust outlet connection does not exceed the maximum allowable back pressure specified in Technical data.

### Note!

1. The flue outlet of gas dryer shall be female and shall allow connection to a flue duct whose diameter complies with the standards in force in the country where the appliance is to be installed.
2. When installing the exhaust duct of the gas dryer, keep a certain angle with the vertical wall so that any condensate formed when operating the appliance from cold can be discharged.
3. The connection where the exhaust duct connects to the dryer should be sealed with steel clamp or duct tape to prevent escaping the combustion products from the machine.
4. For gas dryer, vertical venting is prohibited.

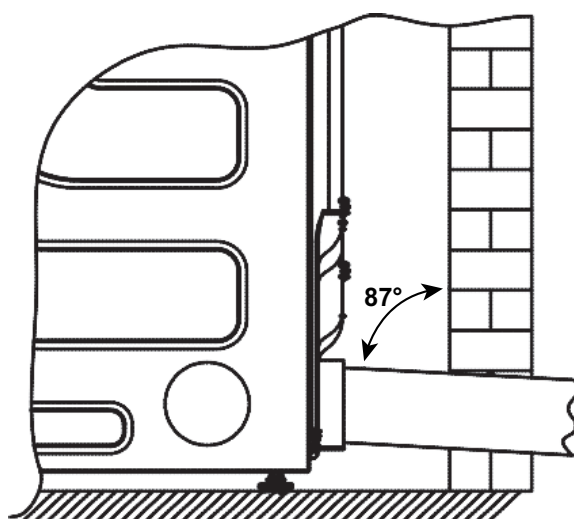

## 6.6 Outside Ductwork Protection

To protect the outside end of the horizontal ductwork from the weather, a 90° elbow bent downward should be installed where the exhaust exits the building. If the ductwork travels vertically up through the roof, it should be protected from the weather by using a 180° turn to point the opening downward. In either case, allow at least twice the diameter of the duct between the duct opening and the nearest obstruction.



### Important



Do not use screens, louvers, or caps on the outside opening of the exhaust ductwork.

## 7 Electrical connection

### 7.1 Electrical installation



The electrical installation may only be carried out by qualified personnel.



It is important to know that the machines are designed to provide a high level of personal safety, which is why items of external equipment such as earth leakage circuit breakers are not necessary. If you still want to connect your machine across an earth leakage circuit breaker, please remember the following:

- contact a skilled, authorised installation company to ensure that the appropriate type of breaker is chosen and that the dimensioning is correct
- for maximum reliability, connect only one machine per earth leakage circuit breaker
- it is important that the earth wire is properly connected.

In instances where the machine is not equipped with an omni-polar switch, one must be installed beforehand.

In accordance with the wiring rules: mount a multi-pole switch prior to the machine to facilitate installation and service operations.

The connecting cable shall hang in a gentle curve.

### 7.2 Single-phase connection

For electric heated dryer, demount the cover panel from the supply unit. Connect the earth and other wires as shown.

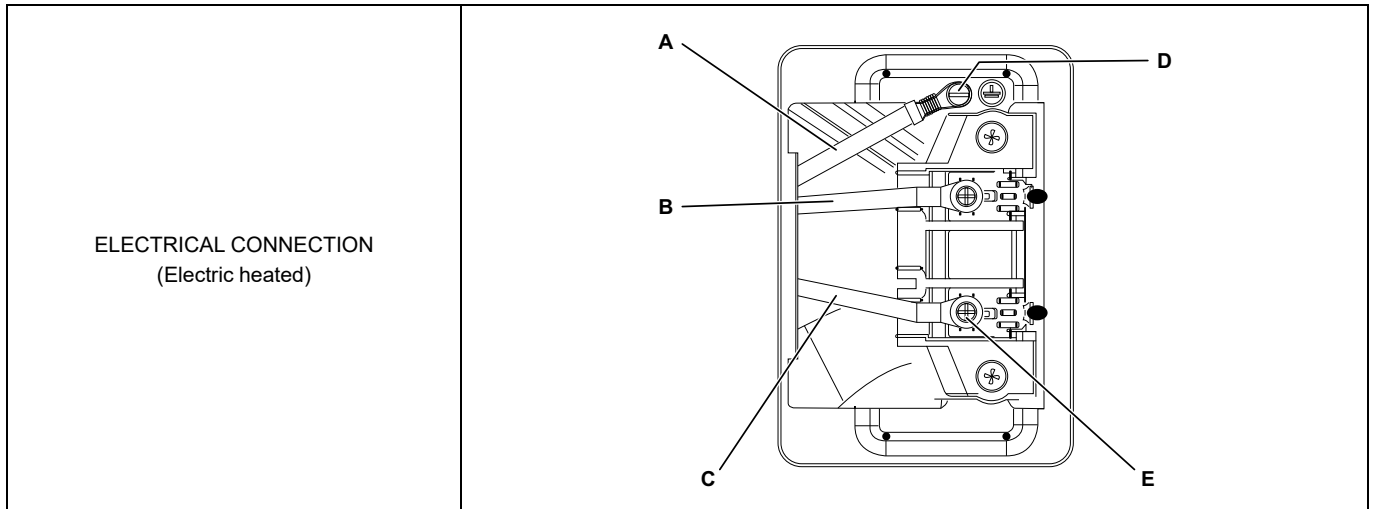

A	G Grounding Wire
B	L Power Cord
C	N Power Cord
D	Ground Screw (Green)
E	Terminal Block Screw

Outlet Receptacle – Properly grounded 3-prong receptacle to be located, so the power cord is accessible when the dryer is in an installed position.

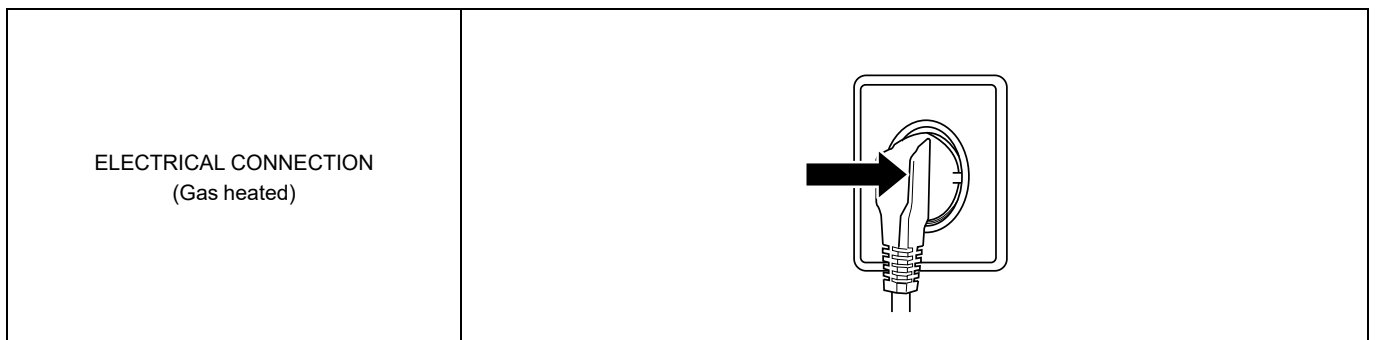

**When the installation is completed remount the cover panel and check:**

- That the drum is empty.
- That the machine operates by connecting the power to the machine and start a program with heat.

### 7.3 Electrical connections

Heating	Main voltage	Hz	Heating power	Total power kW	Recommended fuse A
Electric heated	220–240V	50	4.84 kW	5.0	30
	220–240V	60	4.84 kW	5.0	30
Gas heated	220–240V	50	5.7 kW	1.1	10
	220–240V	60	5.7 kW	1.1	10

## 7.4 Install the Electronic Coin Meter (Coin Operated Models)

1. Unlock control panel with the provided key.
2. Loosen four screws in the control panel.
3. Extract the four terminals of the display PCB, and remove the main control panel, then demount the control panel seat.
4. Install the coin meter faceplate into the control panel seat with two hexagonal disc nuts, then assemble the coin meter into the faceplate with two hexagon self-locking nuts.
5. Connect the eight-pin terminal to the harness, then fix the harness onto the crossbeam with a plastic clip

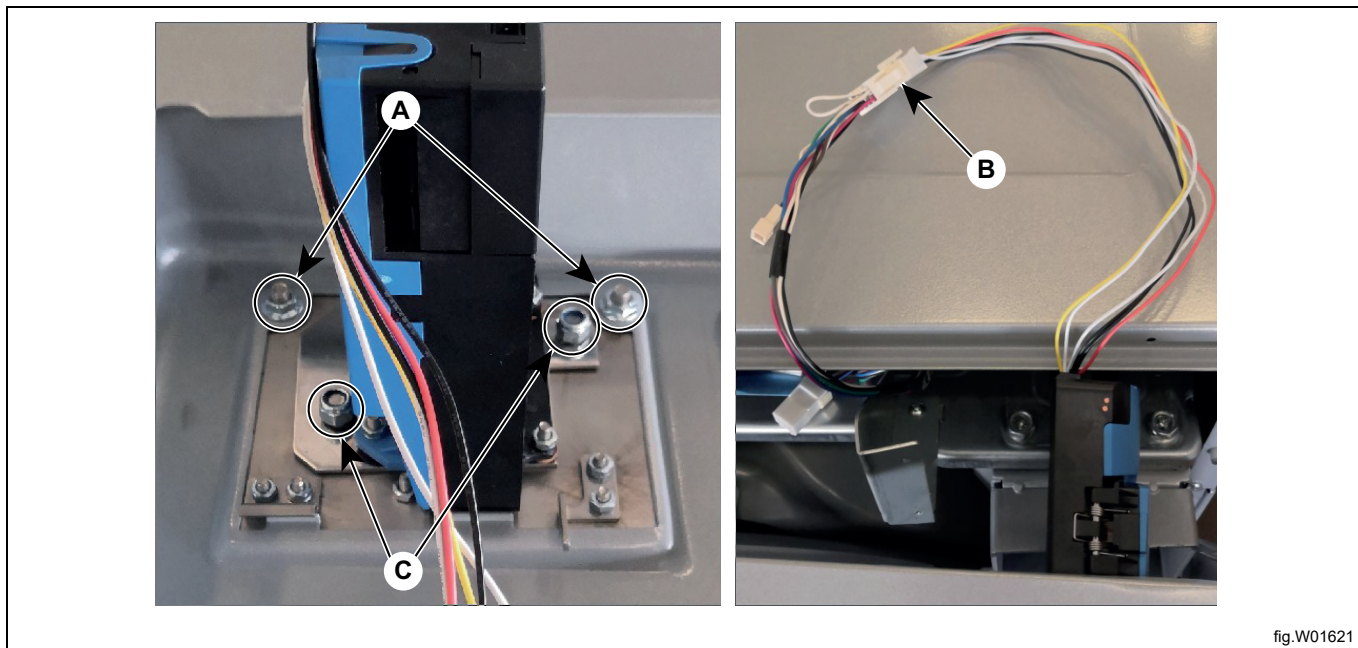

fig.W01621

A	two hexagonal disc nuts
B	eight-pin terminal
C	two hexagon self-locking nuts



6. Mount the control panel seat carefully, don't damage the coinmeter.
7. Reinstall the control panel seat by using the four screws.

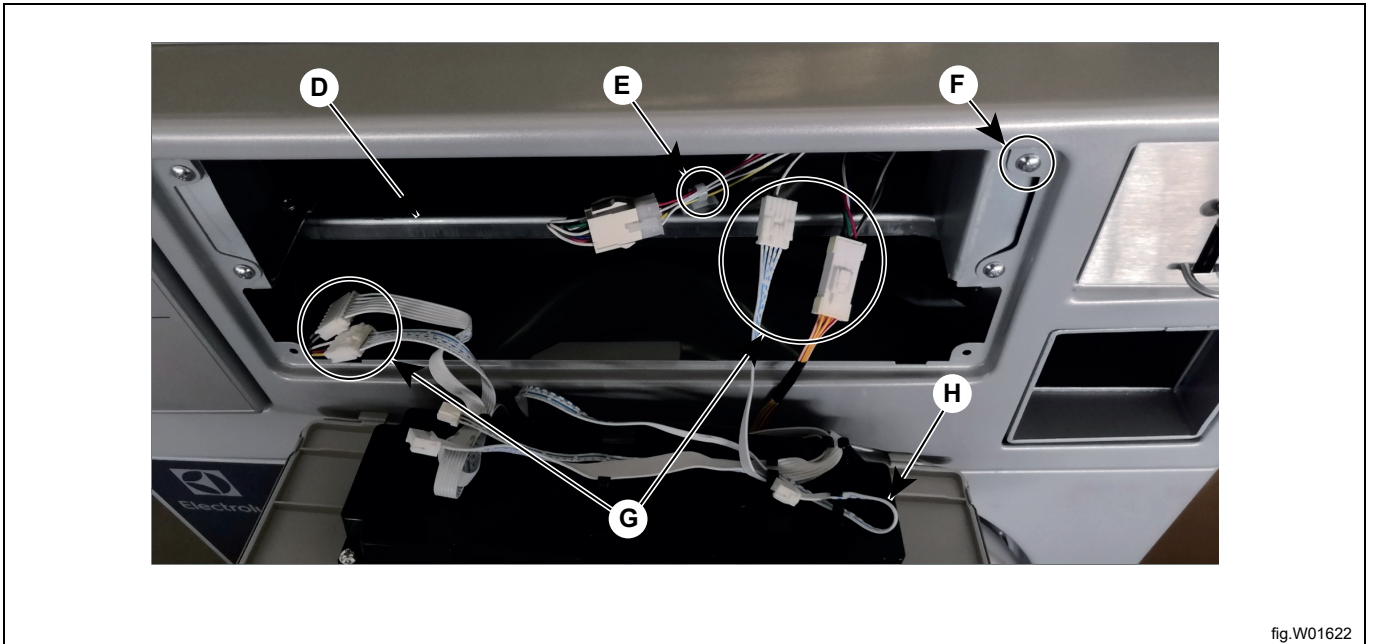

fig.W01622

D	the crossbeam
E	plastic clip
F	total four screws
G	the four terminals of the display PCB (Electric heated)
H	main control panel

8. Connect the four terminals of the display PCB, the above figure shows the connection of four terminals of electric heating dryer, but for the gas heated dryer, the four terminals are directly connected to the display board.
9. Locking main control panel with the provided key.

## 8 Gas connection

### 8.1 Fasten the label

Before installing the machine fasten the label the “user instructions” on the inside of the door in a suitable place and at the front panel.

The label must have the correct country code, choose the correct label from the gas kit.

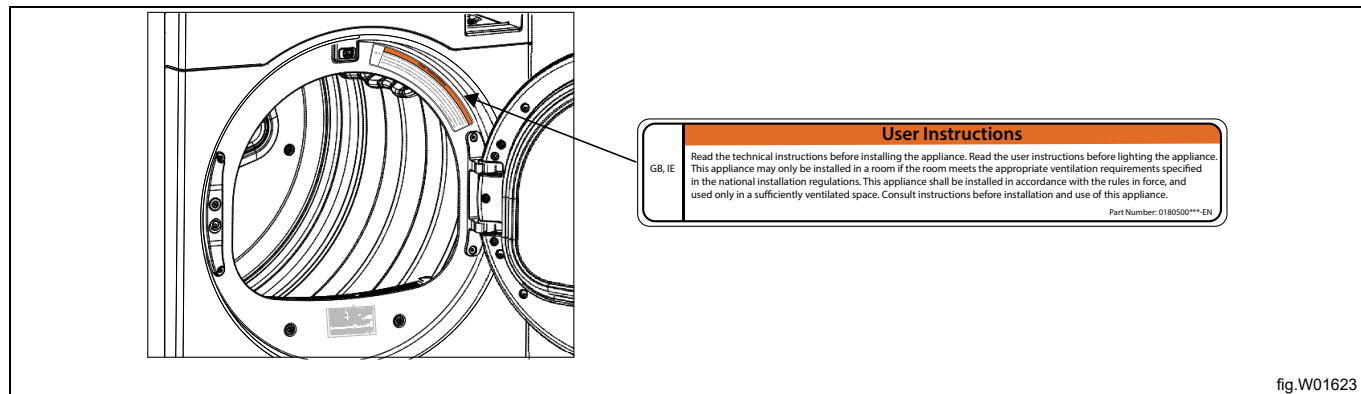

### 8.2 General



May only be carried out by qualified personnel.



Mount a shut-off valve upstream from the machine.

The factory injector pressure setting corresponds to the fuel value given on the data label.

Check that the injector pressure and fuel value correspond with the values in the gas tables on the following pages. If not, contact the supplier.

#### **Note!**

**After connection all joints must be checked. There must not be any leaks.**

### 8.3 Connect the dryer to the gas supply

1. Remove the cap from the end of the gas inlet.
2. Install a female 3/8" NPT adapter at the end of the dryer gas inlet, the male size of the adapter is R1/2".
3. Attach the flexible metal gas line connector to the adapter.
4. Tighten the flexible gas line connection, using two adjustable wrenches.



## Important



Apply pipe compound or PTFE tape to the threads of the adapter and dryer gas inlet.

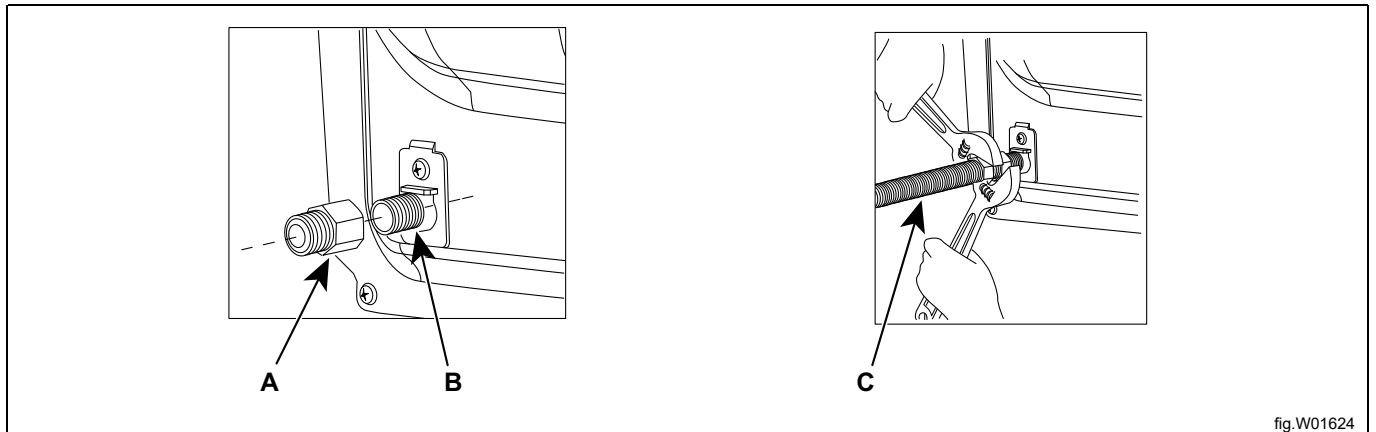

A	Adampter
B	3/8" NPT gas inlet
C	the flexible metal gas line

### 8.4 Gas installation

This gas appliance is built to run on natural gas (group I2H), commonly identified by the nameplate on the dryer. The following table lists the country abbreviations.

AL	Albania
AT	Austria
BE	Belgium
BG	Bulgaria
CH	Switzerland
CY	Cyprus
CZ	Czech Republic
DE	Germany
DK	Denmark
EE	Estonia
ES	Spain
FI	Finland
FR	France
GB	UnitedKingdom
GR	Greece
HR	Croatia
HU	Hungary
IE	Ireland

IS	Iceland
IT	Italy
JP	Japan
LT	Lithuania
LU	Luxembourg
LV	Latvia
MK	Republic of Macedonia
MT	Malta
NL	Netherlands
NEC	Non-europeancountries
NO	Norway
PL	Poland
PT	Portugal
RO	Romania
SE	Sweden
SI	Slovenia
SK	Slovakia
TR	Turkey

You should check the kind of energy gas that is available in your place.

There are many gas types of the same kind but the machine should be equipped with different kinds of injectors depending on the gas type.

## 8.5 Table of pressure

The data label shows the injector size and the injector pressure and the countries that use this gas quality:

(Pressure: 1mmH<sub>2</sub>O=10Pa=0.1mbar)

Liqued petroleum gases	Gas category	Inlet pressure (mbar)	Injector pressure (mbar)	Injector size (ø mm)	Reference gas	Label code	May be available in following countries
Butane	3B/P	30	27.4	1.21	G30	Sticker D	AT, BE, CY, CZ, DE, DK, EE, FR, GB, HR, HU, IT, LT, NL, NO, RO, SE, SI, SK
Propane	3P	37	36	1.21	G31	Sticker C	BE, CH, CZ, ES, FR, GB, GR, HR, IE, IT, LT, NL, PL, PT, SI, SK, TR

Natural gas	Gas category	Inlet pressure (mbar)	Injector pressure (mbar)	Injector size (ø mm)	Reference gas	Label number	May be available in following countries
	2H	20	7.7	2.26	G20	Default	AT, CH, CY, CZ, DK, EE, ES, FI, FR, GB, GR, HR, IE, IT, LU, LV, LT, NO, PT, RO, SE, SK, SI, TR
		25					HU
	2E	20					DE, PL, RO

## 8.6 Test run

- Select a program with heat.
- Start the machine.
- Check the injector pressure, see 8.5 *Table of pressure*.
- Check that the gas is burning evenly.

## 8.7 Converting instructions

**This conversion shall be installed by a qualified service agency in accordance with the manufacturer's instructions and all applicable codes and requirements of the authority having jurisdiction. The information in these instructions must be followed to minimize the risk of fire or explosion or to prevent property damage, personal injury, or death. The qualified service agency is responsible for the proper installation of this kit.**

This conversion need the parts as below:

### Parts List

#### Parts List

1 INJECTOR	Burner-Butane or Propane
1 STICKER A	LP Gas Valve Sticker
1 STICKER B	Conversion Record
1 STICKER C	Rating Plate Conversion of Propane Gas
1 STICKER D	Rating Plate Conversion of Butane Gas

This dryer has been manufactured for use with Natural gas. If need convert to LP, please read these instructions before proceeding. This dryer is converted for use with L.P. gas, for altitudes up to 10,000 feet. For installations above 10,000 feet, contact a qualified service agency for derating instructions.

1. Unplug dryer or disconnect power.
2. Turn off gas supply using the shut-off valve that supplies the dryer.
3. Remove the lower panel.

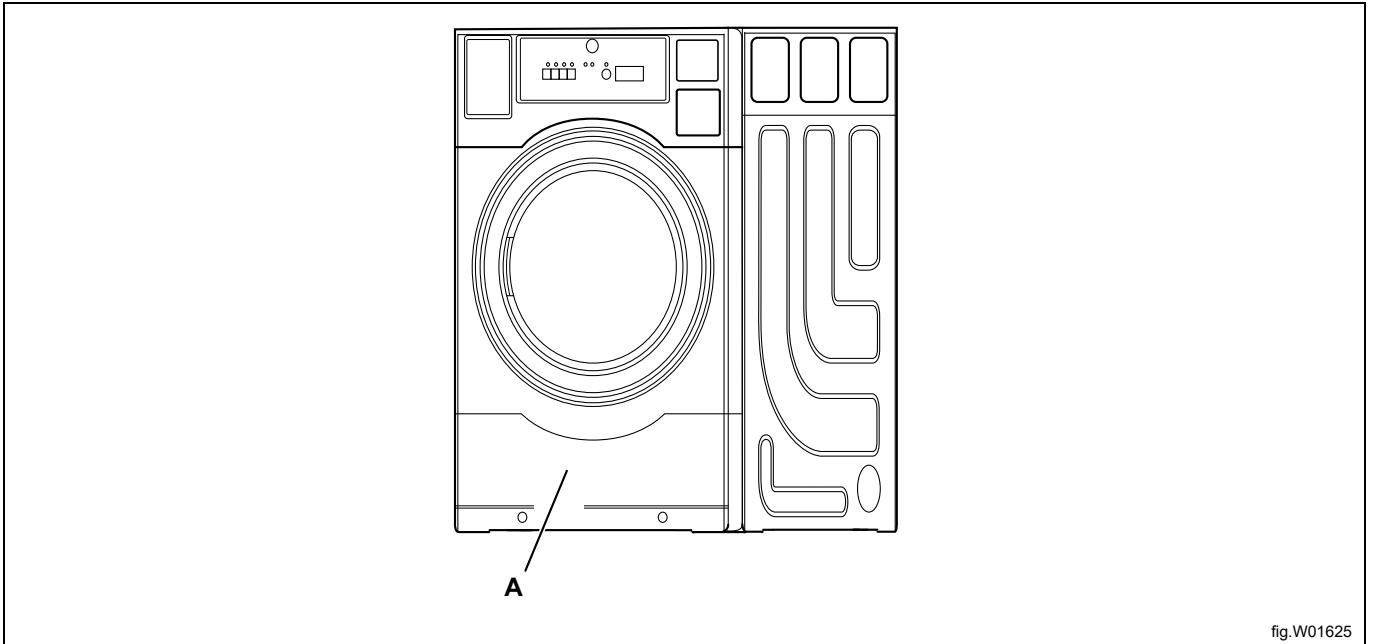

fig.W01625

A	The Lower Panel
---	-----------------

4. Shut off the gas pipe valve.
5. Use a wrench to loosen the hexagon nut union counterclockwise.

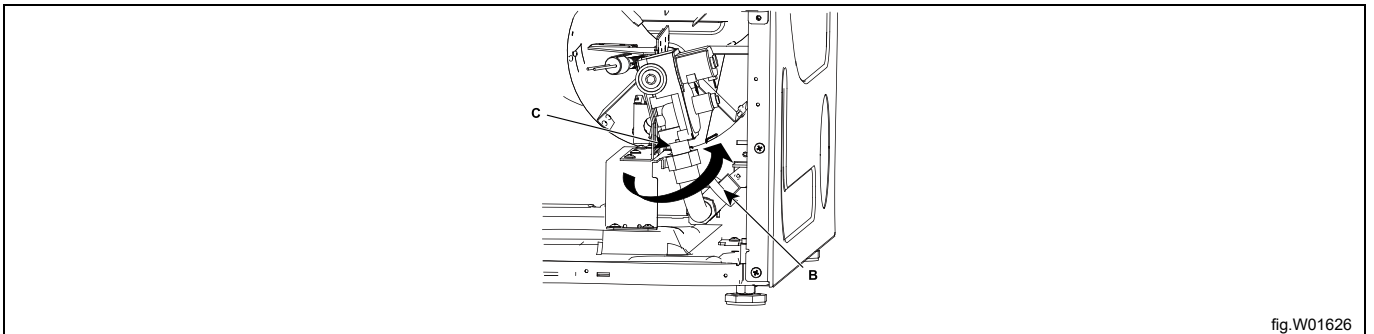

fig.W01626

B	gas pipe valve
C	union

6. Remove the two screws with cross screwdriver.

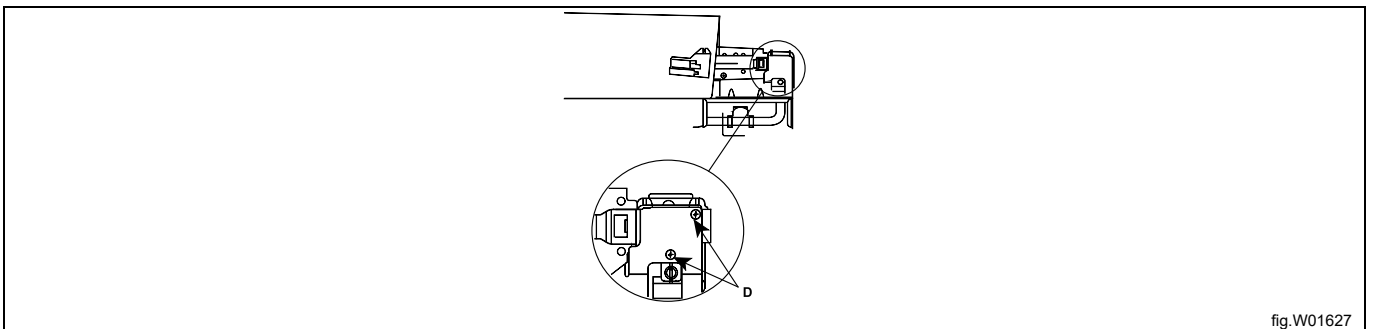

fig.W01627

D	the two screws
---	----------------

7. Disconnect ignitor wires from harness and then take out the gas valve.
  8. Remove the burner injector from the valve and replace it with the injector inside the accessory bag. Torque the new injector to 30 in-lbs (3.4 N·m).
- Use the injector (diameter 1.21mm) for both Butane gas and Propane gas**
9. Grab the dimples (not the cap) with the lips of needle nosed pliers to twist the cover until the marking LPG point toward the base point.
  10. Apply STICKER A (LP Gas Valve Sticker) over the existing valve label.
  11. Put the gas valve back on the burner assembly. Securely tighten the two mounting screws. Reconnect the valve to the harness.
  12. Check all connections to ensure no leakage with referring to the method of leak check as the next page.
  13. Connect a manometer to measure the injector pressure, its details of the pressure test as below.

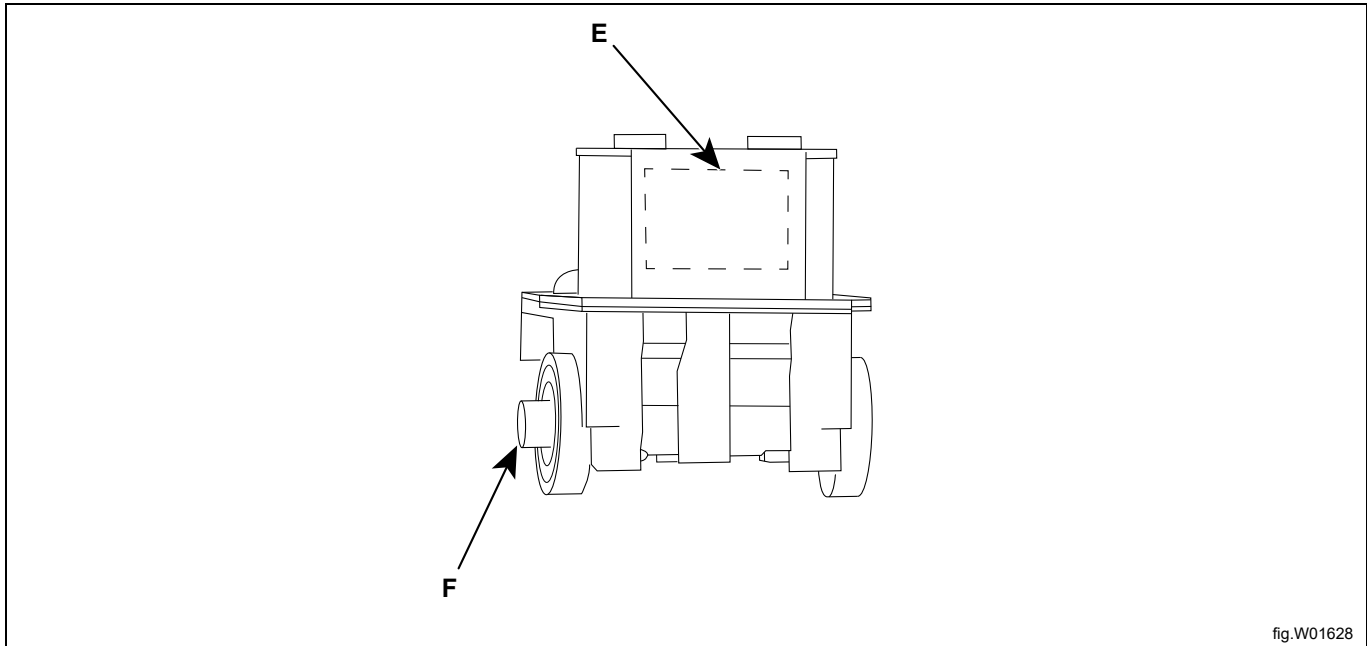

fig.W01628

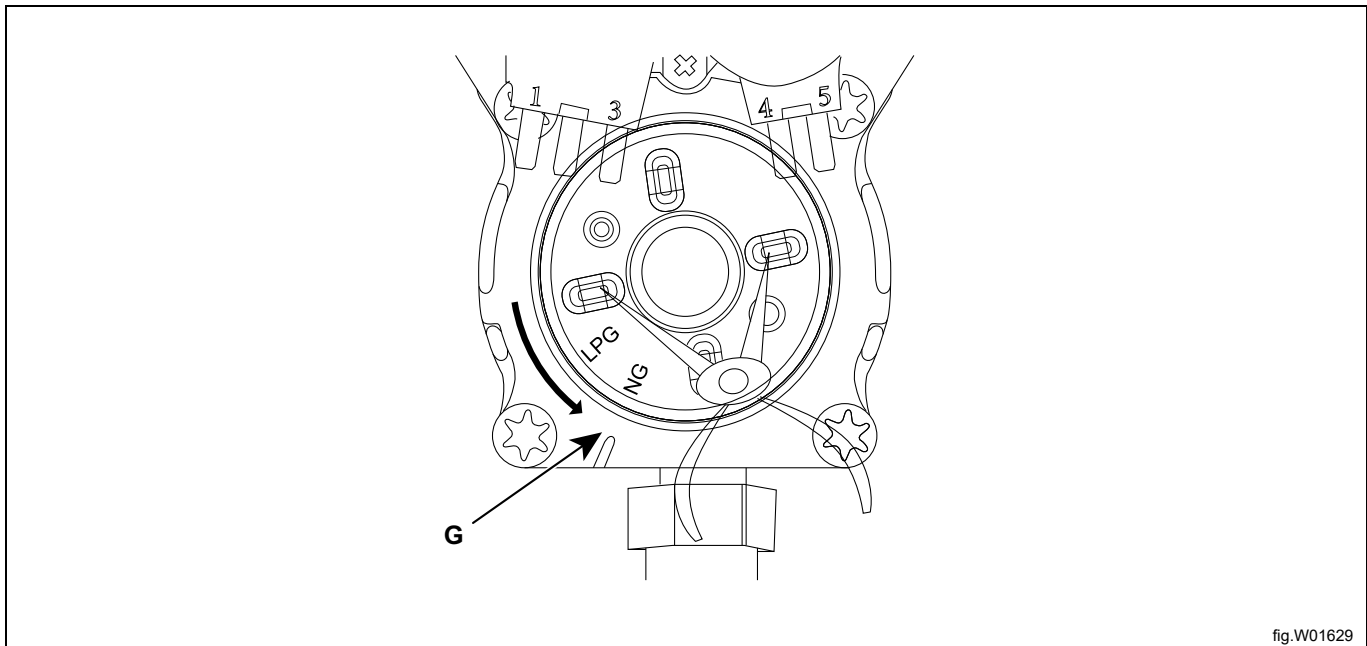
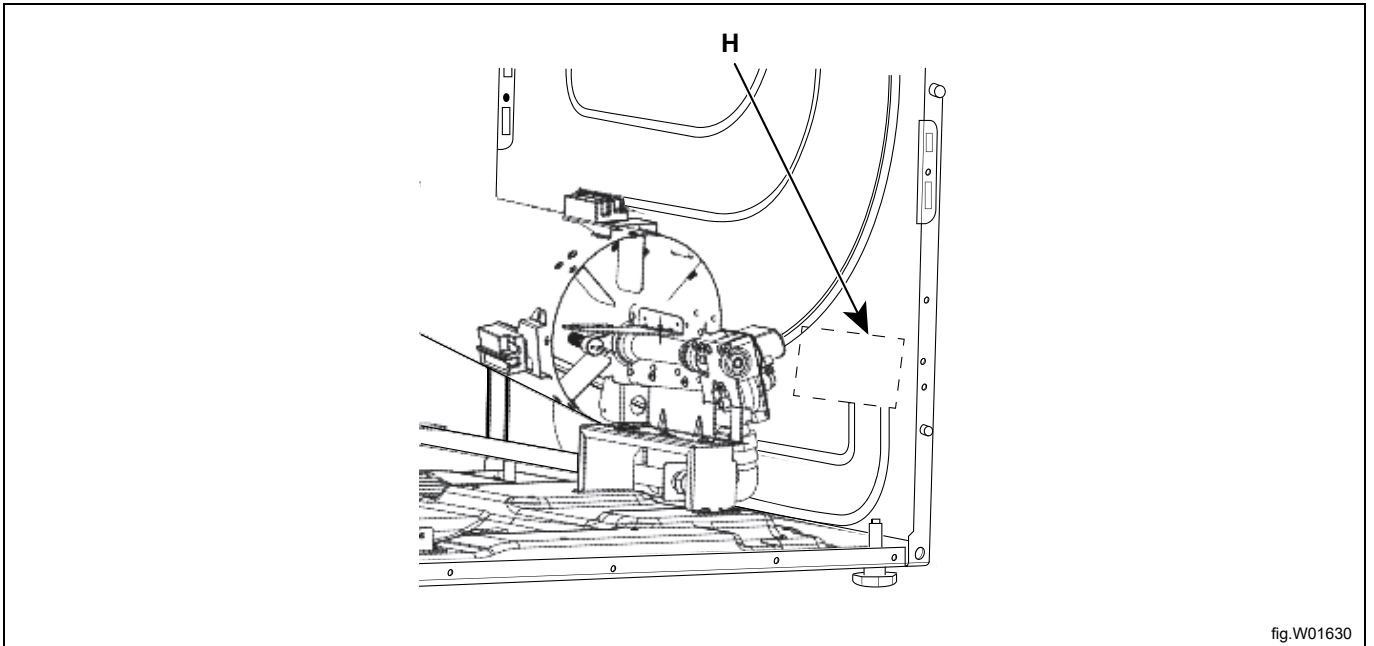

fig.W01629

E	Apply STICKER A Here
F	the New Injector
G	Base Point

14. Sign and date one of the STICKER B (Conversion Record) and apply it on the right side panel adjacent to the gas valve.
15. Reinstall the lower panel.



H	Apply STICKER B Here
---	----------------------

**Leak Check**

1. Turn on gas supply.
2. Plug in dryer or reconnect power.
3. Set dryer cycle to time high heat and turn on dryer.
4. Brush or spray an approved noncorrosive leak-detection solution onto pressure tap and union nut (if applicable) and inspect for leaks indicated by growing bubbles.
5. If any bubbles are present, turn off gas supply, tighten the leaking connection and retest for leaks.
6. If dryer was moved during conversion, use the same method to check for leaks in the flexible gas supply line and fittings between the dryer and the gas supply pipe.
7. If any bubbles are present, tighten the leaking connection and retest for leaks.
8. Unplug dryer or disconnect power.

**Pressure Test**

1. Loosen the pressure measuring screw in the test nipple.
2. Connect the airtight hose to the pressure test nipple. (Airtight hose will attach between the pressure test nipple and manometer).
3. Connect opposite end of hose to manometer.
4. Connect electrical service and turn on gas supply to the dryer.  
Then turn on gas pipe valve.
5. Check gas valve pressure as follows:
  - a. Connect manometer to tubing.
  - b. Start dryer using high temp setting.
  - c. Check the injector pressure, see 8.5 *Table of pressure*.
  - d. Turn off the dryer.
6. Unplug dryer or disconnect power.
7. Turn off gas supply.
8. Disconnect manometer .
9. Remove hose from the pressure test nipple.
10. Tighten pressure screw to gas valve.

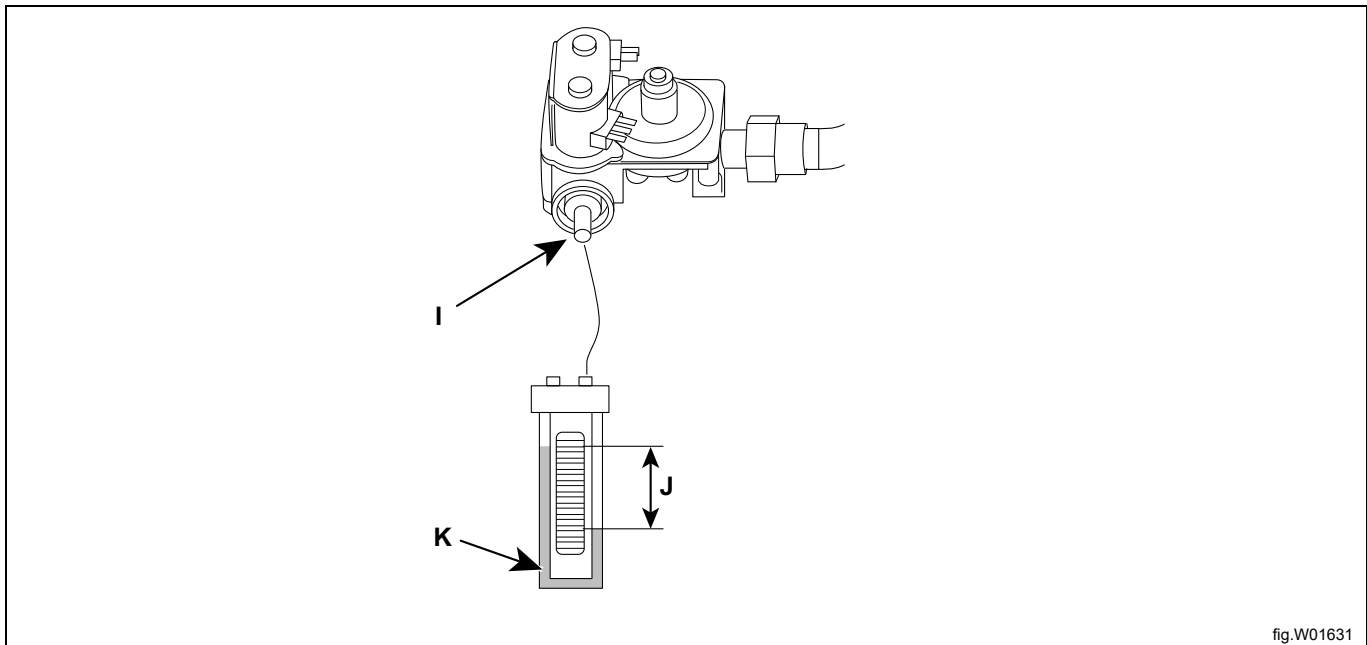

fig.W01631

I	Test Nipple
J	<b>Injector Pressure</b> (see 8.5 <i>Table of pressure</i> )
K	"U"Tube Manometer



### 8.8 Data label

When the machine is to be converted to another gas type, the data label at the front panel of the machine must be updated in order for the data to be correct.

Select the Sticker C (Rating Plate of Propane Gas) or Sticker D (Rating Plate of Butane Gas) in the accessory bag covering the original data label as shown below.

Note the correct country code and gas type.

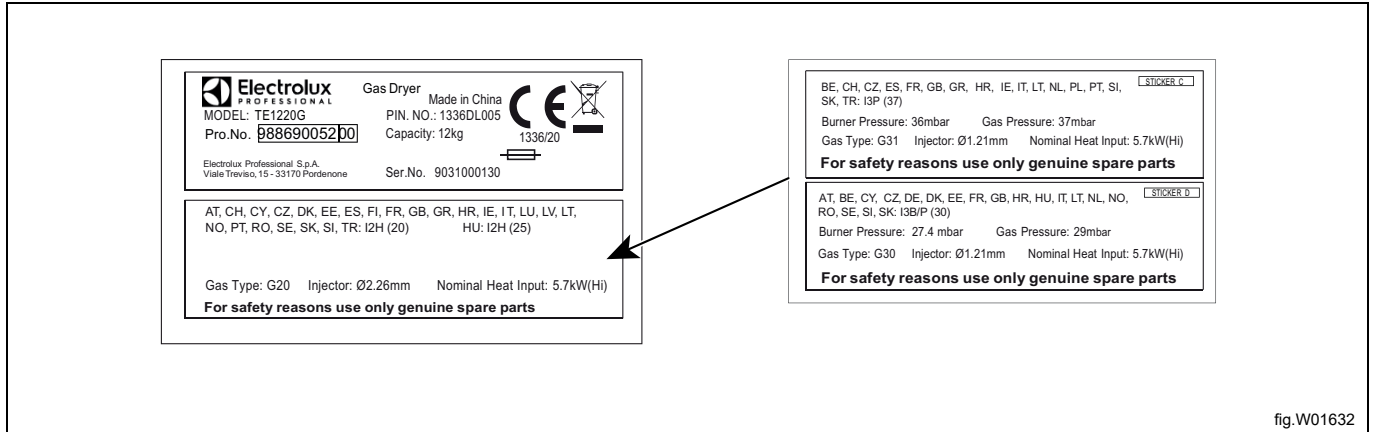

fig.W01632

## 9 Coin meter operation

In coin operated machines prices for programs and other operational parameters must be programmed during machine setup.

Prices can be programmed as Euros or as the number of coins or tokens required to start and to add additional drying time.

There are four drying programs High, Medium, Low, and No Heat. These four programs can be programmed for different prices and times. When the machine is in standby mode (i.e. before the drying program begins), the selected drying program may be changed. Once a drying program has started, the program may be changed only if all the programs High, Medium, Low and No Heat have identical settings for price, drying time, and time added for each additional coin or press.

After the initial drying time has been purchased for a selected program, additional drying time may be added by inserting more coins. The amount of extra time per coin inserted for the selected program can be programmed in the service registers. Additional drying time up to the maximum allowed may be purchased.

### 9.1 Price Programming & Drying Time Program Setup

Amount to Start (ATS) service registers 040-043 define the price that must be paid before a selected program may be started.

The ATS price is displayed when the machine is idle. As each coin is deposited the display will count down by the "Coin 1 Value" or "Coin 2 Value" as the coin pulses are received. The following instructions show how to set up prices for drying programs.

1. Unlock and separate the PCB assembly from the control panel seat.
2. Press the reset button for 2 seconds , then release the finger to enter service mode.

When you enter the service mode successfully by this method, the PCB will display 8888

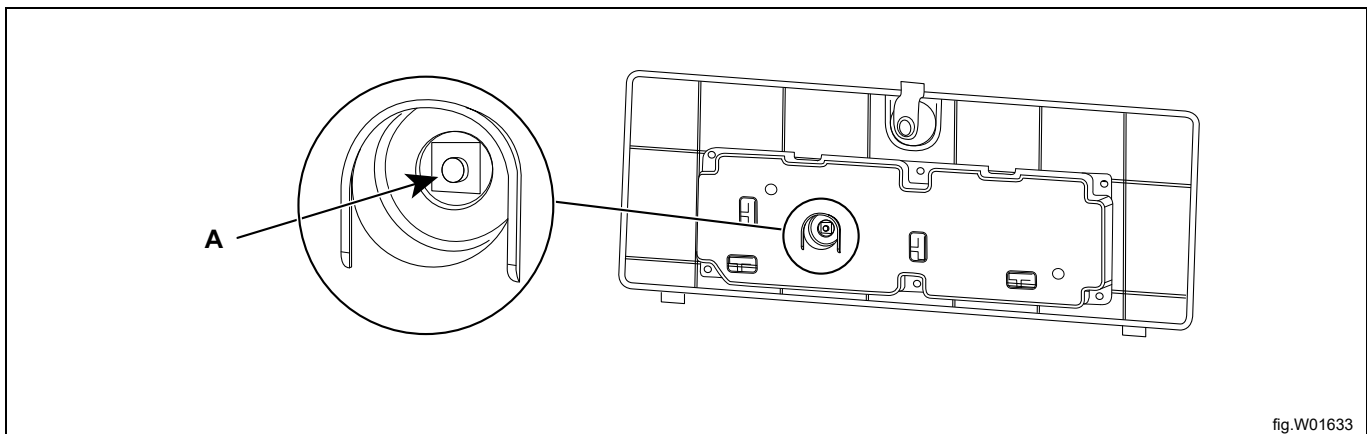

fig.W01633

A	reset button
---	--------------

3. Press the start button, "SE" shall appear in the display confirming access to the service registers.
4. Use the "Low" and "No Heat" buttons to navigate to the desired register.
5. Go to register 40, High heat and press Start to enter. The current price will be shown in the display, blinking.
6. Use the three program selection buttons; Medium, Low, and No Heat to change each of the three digits in the price display. Each button increments a corresponding digit, left to right, in the price. Each digit rolls over from 9 to 0 without affecting the other digits. Once the desired price has been set in the register, press the Start button to save the value and exit the register.
7. If registers 041, 042, and 043 = "0.00" the values of these registers will be set to the same value as register "040". If different pricing is desired, program each register separately repeating steps 4-5.
8. Press the Service Switch in the vault to exit service mode.
9. Check the newly entered prices by selecting each program.

Register 030 (Coin / Token Mode) determines how prices are displayed by the machine. When set to "00" (default), prices are set and displayed with a decimal (e.g. "3.00"). When set to "01", the decimal point is turned off, and prices are set and displayed as "number of coins or tokens" required (e.g. "12"). In either case, the value of each coin drop is stored in Register 031 "Coin Value 1" and Register 032 "Coin Value 2" and determine how much the remaining price will be reduced each time a coin is deposited. The coin-value registers can be adjusted to accommodate any currency.

## 9.2 Free Dry / OPL Mode

When the Amount To Start (ATS) register for a program is set to 0.00 (00 in “token mode”), the program operates in “Time per push mode” (this is free dry mode). In this mode, each time a program button is pressed, the remaining time is incremented. The first press adds the “Time for Amount to Start” register value (Register 044 – 047) to the drying time, and then each additional press continues to add the “Time per Push or Coin” (Register 048 – 051) to the drying time. These registers are only accessible in Full Service Mode. In no case shall the displayed remaining dryer time be greater than the “Max drying time” for that program.

Each program (temperature) button has a group of registers (040-055) assigned for setting vend time, price, and maximum allowable time. The registers are organized to provide maximum flexibility for vended operations, yet simple programming for non-vended applications (Free dry).

## 9.3 Price and Time Registers

### 9.3.1 Time for Amount to Start

The time for amount to start registers Register (044–047) defines the time credited when the amount to start has been paid or the base time of the drying program when Amount to start = 0.00 (00 in token mode). This time is credited when a program-selection (temperature) button is pressed for the first time if the remaining drying time = 0. These registers are only accessible in Full Service Mode.

### 9.3.2 Time Per Coin (or Push In Free Dry Mode)

Register (048 — 051) defines the time, in minutes, that is credited when a coin pulse is received from a payment device or when a program button is pressed when amount to start (ATS) Register (040 - 043) = 0, AFTER the initial “Time for amount to start” has been credited, whether the machine is idle or operating. This register is only accessible in Full Service Mode. Once these registers are set, the control vends the same amount of time for each coin pulse received from the payment device (or push of a program button if Amount to start = 0 for that program), up to the Maximum drying time specified for the particular program.

## 9.4 Promotion programming (for extra drying time)

The dryer can apply “Promotion” percentage discount to the vend price of a program selection at specified times and days. Up to four different promotion discount events and percentages can be selected using the dryer’s built-in Real Time Clock (RTC) or one promotion event can be selected using an optionally-installed, external signal provided by a clock-driven relay or switch. This signal can activate multiple dryers. Both options require setup via the service registers, access to which is described in the Service Mode section of this manual.

During machine setup, the promotional discount is represented by a three-digit percentage (%%%) and can range from 000% (no discount) to “999” = 9999%. It defines the percentage by which credited time shall be increased before being added to the base price of the drying program. For example, if “Time for amount to start”, (Register 044 – 047) = 30 and Time for additional coin or push, register (048 – 051) = 10 and promotion percentage = 50, then 45 minutes shall be credited when the Amount to start is paid and 15 minutes shall be credited when additional coin 1 pulses are received. Setting the promotion to “A00” sets the machine to free dry mode.

Note that the remaining drying time will not exceed the Maximum Drying Time established for each program in the Maximum Drying Time registers (052 - 055).

## 9.5 Promotion via the real time clock (RTC)

The RTC and Promotion times are set and displayed in 24hr format. (e.g. 1:15 PM = 13:15). The promotion days of the week are represented by a two digit number (nn). The RTC's built in calendar adjusts for leap years. Promotion set up requires setting the RTC and up to four pairs of Promotional start and stop times and percentages.

### RTC and Promotional Setup

1. Navigate to Register 72 (RTC set-up) as explained in the Service Mode section.
2. Press START, this will stop the clock. The year will be displayed as a four digit number (yyyy). Edit these values using the HIGH, MEDIUM, LOW, and NO HEAT buttons.
3. Press START, the Month and Day will be displayed as two-digit numbers (mm.dd). Edit these values using the HIGH, MEDIUM, LOW, and NO HEAT buttons.
4. Press START, the Hour and Minutes will be displayed in 24 hr format as two digit numbers (hh.mm). Edit these values using the HIGH, MEDIUM, LOW, and NO HEAT buttons.
5. Press START to save the changes and exit register 72. This will reset the clock to the set time, reset the clock's seconds digit to "00", and restart the clock. This allows synchronizing the clocks on multiple machines to a master clock such as a wall clock, wristwatch, or cell phone.
6. Navigate to Register "73" (RTC Promotion #1 START) to set the percentage discount, day of the week and start time for promotion #1.
7. Press START, a two-digit day number ("0d") for which the start day(s) of the week for promotion #1 will be displayed. (1=Sunday, 2=Monday, ... 7=Saturday, 8=All days, 9=Monday-Friday only, A=Saturday and Sunday only, 0=promotion is inactive.) Edit this number using the NO HEAT button to cycle through the allowed values.
8. Press START, the Hours and Minutes in 24 hr format for the start of Promotion #1 will be displayed (hh.mm). Edit these values using the HIGH, MEDIUM, LOW, and NO HEAT buttons.
9. Press START, the promotion percentage discount will be displayed as three digits (%%%). The discount can range from "000" = 000% to "999" = 999%. Setting the promotion to = "A00" will allow free drying). Edit this number using the Medium, Low and No Heat buttons. Note, pressing the Medium button ten times will cycle the value to "A00".
10. Press START to save the changes and exit Register "73"
11. Navigate to Register "74" (RTC Promotion #1 END). This will allow you to set the end time for promotion #1.
12. Press START, the promotion end time in hours and minutes in 24 hr format will be displayed (hh.min). Edit these values using the HIGH, MEDIUM, LOW, and NO HEAT buttons.
13. Press START, this will save the changes and exit register 74.
14. Program the three other Promotion times and percentages as desired using register pairs: 075 & 076 (Promotion #2), 077 & 078 (Promotion #3), and 079 & 080 (Promotion #4). Each promotion can have a different percent reduction. They must not overlap with each other.
15. Exit Service Mode.

## 9.6 Promotion via external clock-driven relay or switch

This dryer can apply a Promotion price discount using an external clock-driven relay or manual switch. To use this feature the dryer requires an optional external price reduction harness kit be installed. Refer to the kit's installation manual for information regarding connecting this signal to the dryer to activate discounts.

### Parameter memory register assignments

1. Navigate to Register 081 (Promotion %%% for discount input signal) as explained in the Service Mode section.
2. Press START the promotion percentage discount will be displayed as three digits (%%%). The discount can range from "000" = 0% to "999" = 999% Setting to "A00" will allow free drying. Edit this number using the Medium, LOW and NO HEAT buttons.
3. Press START, this will save the changes and exit register 081.
4. Exit Service Mode.

When the external signal is activated, the DRYER will apply Promotion set in register 081, to increase the drying time as explained elsewhere in this manual.

Please contact Electrolux Professional local contact's Technical Support team if you have any questions or need assistance with price programming or implementing promotion events.

## 10 Function check



May only be carried out by qualified personnel.



A function check must be made when the installation is finished and before the machine can be ready to be used. Whenever a repair has been made, a function check must be performed before the machine can be used again.

Check the automatic stop of the machine

- Start the machine.
- Check if the micro switches are working properly: The machine must stop if the door is opened.

Check the heat

- Let the machine work for five minutes on a program with heat.
- Check that the heating is working by opening the door and feel if there is heat in the drum.

Ready to use

If all tests are OK the machine is now ready to be used.

If some of the tests failed, or deficiencies or errors are detected, please contact your local service organisation or dealer.

The installer shall instruct the user on the operation of the appliance before leaving.

## 11 CPU reset

A CPU reset will return the machine's registers and temperature settings to default values. The machine will be set to COIN mode and pricing cleared.

To finish CPU reset, you need to follow the below two steps:

1. Unlock and separate the PCB assembly from the control panel seat.
2. Press and hold the reset button for 6 seconds on the back of the PCB assembly until hear "Bi-Bi" sound and show 0.00 on the screen, then release the finger to finish reset setting.

## 12 Disposal information

### 12.1 Disposal of appliance at end of life

Before disposing of the machine, make sure to carefully check its physical condition, and in particular any parts of the structure that can give or break during scrapping.

The machine's parts must be disposed of in a differentiated way, according to their different characteristics (e.g. metals, oils, greases, plastic, rubber, etc.).

Different regulations are in force in the various countries, therefore comply with the provisions of the laws and competent bodies in the country where scrapping takes place.

In general, the appliance must be taken to a specialised collection/scrapping centre.

Dismantle the appliance, grouping the components according to their chemical characteristics, remembering that the compressor contains lubricant oil and refrigerant fluid which can be recycled, and that the refrigerator and heat pump components are special waste assimilable with urban waste.

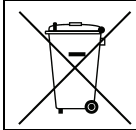

The symbol on the product indicates that this product should not be treated as domestic waste, but must be correctly disposed of in order to prevent any negative consequences for the environment and human health. For further information on the recycling of this product, contact the local dealer or agent, the Customer Care service or the local body responsible for waste disposal.



#### Note!

**When scrapping the machine, any marking, this manual and other documents concerning the appliance must be destroyed.**

### 12.2 Disposal of packing

The packing must be disposed of in compliance with the current regulations in the country where the appliance is used. All the packing materials are environmentally friendly.

They can be safely kept, recycled or burned in an appropriate waste incineration plant. Recyclable plastic parts are marked as following examples.

	Polyethylene: <ul style="list-style-type: none"> <li>• Outer wrapping</li> <li>• Instructions bag</li> </ul>
	Polypropylene: <ul style="list-style-type: none"> <li>• Straps</li> </ul>
	Polystyrene foam: <ul style="list-style-type: none"> <li>• Corner protectors</li> </ul>





Electrolux Professional AB  
341 80 Ljungby, Sweden  
[www.electroluxprofessional.com](http://www.electroluxprofessional.com)