

Washer extractor

WH6-8



Exceptional savings and effortless use



Priority on people

Certified ergonomic design with a human-centered approach for an outstanding user experience

Compass Pro® microprocessor offers:

- Easy program selection
- Language selection
- Quick selection and option buttons for the most frequently used wash programs and options
- Wash program packages optimized on Economy, Performance and Time
- By using the Laundry Program Manager tool you can edit and create new programs to adapt to the requirements of your business



Long-term savings

Innovative features designed for lowest possible water, energy and detergent consumption, to save money and time, and embrace a sustainable lifestyle

- Automatic Savings weighs the linen and adjusts the water level to the amount of linen, saving water and energy at less than full load
- Power Balance measures, corrects the unbalance and adjusts the G force in real time, maximizing the dewatering, saving money and time in the drying process



Pure control

Monitoring of the status of the equipment and performance from anywhere, allowing to take action to improve the business

- Washers connectable to OnE Connected, the personal assistant for hygiene validation, process management and revenue management



Global Advanced Hygiene

Global Advanced Hygiene program package^I with proven log 6 reduction^{II} disinfection of textiles through the laundry process, fulfilling the criteria of all local approved standards

I. Programs available in the standard library of all products, excluding products for specific segments where water temperature is not controllable.

II. Log 6 reduction equals to 99,9999% viral infectivity reduction. The efficacy of reduction of SARS-CoV-2 and other pathogens in the process is confirmed by RISE (The Research Institute of Sweden) on the basis of Electrolux Professional laboratory data.



Images shown are a representation of the product only and variations may occur.

Main options

- Savings on chemicals with help of Efficient dosing, both ED peristaltic pumps and ED Venturi
- Connection to booking- /payment- system or coin meter

Main specifications		WH6-8			
Rated capacity, filling factor 1:9	kg/lb	8 / 18			
Drum, volume	litre	75			
Drum, diameter	ø mm	520			
Extraction	rpm	1245			
G-factor		450			
Standard heating alternatives	electricity, kW	5.4 / 7.5			
Low energy heating alternatives	electricity, kW	2.0 / 3.0			
	steam	x			
	non-heated	x			
Consumption data "ECO 60°C"¹		El		Steam ²	
		Full load, 8 kg	Half load, 3.75 kg ³	Full load, 8 kg	Half load, 3.75 kg ³
Total time	Min	57	54	57	54
Water consumption (cold+hot)	litre	46+3	26+3	49+0	29+0
Energy consumption (motor/heating/hot water)	kWh	0.2/0.95/0.15	0.15/0.55/0.15	0.2	0.15
Steam consumption	kg	-	-	1.65	1.05
Residual moisture	%	45	46	45	46

1. Water temperature 15°C cold water and 65°C hot water.

2. Depending on steam pressure.

3. Programs with AS.

Produced according to ISO 9001 and ISO 14001.

Certified with CB certificate for Low Voltage Directive and S-mark according to the Machinery Directive. Protection class IP X4D.

Electrical connections					
Heating alternative	Main voltage	Hz	Heating power kW	Total power kW	Recommended fuse A
Electric heated	220-240V 1/1N-	50/60	3.0	3.4	16
	220-240V 1/1N ¹ -	50/60	5.4/7.5	5.7/7.8	25/32
	220-240V 3-	50/60	3.0	3.4	10
	220-240V 3-	50/60	5.4/7.5	5.7/7.8	16/25
	380-415V 3N/3-	50/60	3.0	3.4	10
	380-415V 3N/3-	50/60	5.4/7.5	5.7/7.8	10/16
	440V 3-	50/60	5.4/7.5	5.7/7.8	10/16
Non heated/Steam heated	208-240V 1/1N-	50/60	¹	1.0	10
	380-480V 1- ²	50/60	¹	1.0	10

1. Total power and recommended fuse does not depend on the heating power in those cases.
2. Prepared for 3-

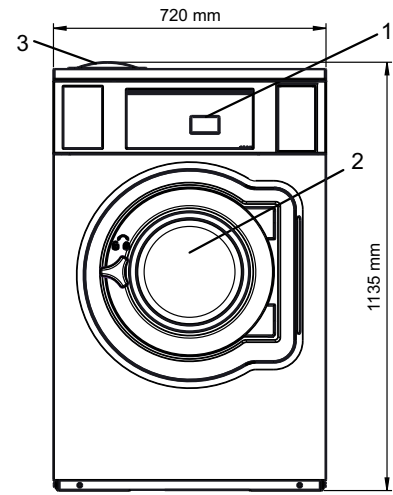

Water and steam connection ¹		WH6-8
Water valves	DN	20
Water pressure	kPa	200-600
Capacity at 300 kPa	l/min	20
Drain valve	ø mm	50/75
Draining capacity	l/min	170
Steam valve	DN	15
Steam pressure	kPa	300-600
Liquid detergent supplies		5

Floor requirements		
Frequency of the dynamic force	Hz	20.8
Floor load at max extraction	kN	1.9 ± 0.5

Sound levels		
Sound power/pressure level at extraction ²	dB(A)	73/59
Sound power/pressure level at wash ²	dB(A)	61/47

Heat emission	
% of installed power, max	5

Shipping data ³		
Weight	net, kg	158
Shipping volume	m ³	0.81

Accessories	
Steel base	x
Hose kits for water or steam	x
Fluff collector	x

- | | |
|---|--|
| 1. Operating panel | 7. Re-used water from tank/pump or Liquid detergent supply |
| 2. Door opening ø 310 mm | 8. Drain |
| 3. Detergent box | 9. Liquid detergent supply |
| 4. Cold water | 10. Electrical connection |
| 5. Hot water | 11. Steam connection |
| 6. Cold/Hot water or Re-used water with network pressure (option) | |

1. The washer extractor is equipped with a built-in type AB airgap according to EN 61770.
2. Sound power levels measured according to ISO 60704.
3. Average data. Crated weight/shipping volume depends on configuration. Please contact logistics for exact measures.

Silver grey and dark blue color samples can be ordered on part number 472998313.

