

Washer extractor

H7-600

Features and benefits

- Flexible Control – programmable microprocessor with 9 fixed and up to 192 programs to allow free programming
- High extraction for efficient dewatering
- Frequency-controlled motor for optimal washing
- Supplied with 8 + 5 signals for liquid detergents
- Eight connections for liquid detergents
- Large door opening for easy loading and unloading
- All critical parts made from stainless steel to provide a high level of corrosion resistance
- Powder painted galvanised steel side panels
- Bearing seals lubricated with oil to ensure a long service life. Empty container alarm
- Electric or direct steam heating
- Designed for easy servicing and maintenance

Main options

- Front mounted loading hopper
- Forward or forward/backward tilting with full reversing function
- Five-compartment detergent box for powder detergent (located at the front or on the right hand side of the machine)
- Third water valve
- Large water valves
- IS – Integrated Saving
- Connection to CMIS



Images shown are a representation of the product only and variations may occur.

Main specifications				H7-600		
Max. capacity		kg/lb	65/145			
Drum, volume		litre	600			
	diameter	ø mm	980			
Extraction		rpm	800			
G-factor			350			
Heating alternatives	electricity	kW	38.4 / 54.0			
	steam		x			
	hot water		-			
Consumption data "Normal 60°C" * (7G01)				Steam**	EI 38.4 kW	EI 54.0 kW
Total time (cold+hot/cold)		min	39/42	42/-	40/-	
Water consumption (cold/hot)		litre	321/92	321/92	321/92	
Energy consumption (motor/heating/hot water)		kWh	1.2/-	1.2/3.5/5.9	1.2/3.5/5.9	
Steam consumption (cold/hot)		kg	7	-	-	
Steam consumption (cold)		kg	14	-	-	

* With filling factor 1:10. Water temperature 15°C cold water and 65°C hot water.

** Steam at 300-400 kPa.

Produced according to ISO 9001 and ISO 14001.

Certified with CB certificate for Low Voltage Directive and S-mark according to the Machinery Directive. Protection class IP X4D.

Electrical connections					
Heating alternative	Main voltage		Heating power kW	Total power kW	Recommended fuse A
		Hz			
Electric heated	220-240V 3 ~	50/60	38.4/54.0	41.0/56.6	125/160
	380-415V 3 ~	50/60	38.4/54.0	41.0/56.6	63/100
	440/480V 3 ~	50/60	38.4/54.0	41.0/56.6	63/80
	220V 3 ~	50/60	49.4	52.0	160
Steam or Non heated	220-240V 3 ~	50/60	-	4.8	20
	380-480V 3 ~	50/60	-	4.8	16

Water, steam and air connection			H7-600
Water valves	DN		25
Rec. water pressure	kPa		200-600
Functioning limits for water valve	kPa		50-1000
Capacity at 300 kPa	l/min		110
Drain valve	∅ mm		110
Draining capacity	l/min		400
Steam valve	DN		20
Rec. steam pressure	kPa		300-600
Functioning limits for steam valve	kPa		50-800
Compressed air	DN		6
Air pressure	kPa		500-700
Air consumption	l/h		20
Five-compartment detergent injector	DN		20
Floor requirements			
Frequency of the dynamic force	Hz		13.3
Floor load at max extraction	kN		16.9 ± 1.4
Sound levels			
Sound pressure level*	dB(A)		76
With insulation	dB(A)		< 70
Heat emission			
% of installed power, max			6
Shipping data**			
Shipping volume	net, kg		1380
	crated, kg		1500
	m ³		5.7

* A-weighted emission sound pressure level at workingstations.

** Average data. Crated weight/shipping volume depends on configuration. Please contact logistics for exact measures.

Dimensions in mm		H7-600
A	Width	1390
B	Depth	1585
C	Height std/tilt+IWS	1975/2015
C	Height, low foot	-
D	std/tilt+IWS	870/910
Ea		300
Eb		210
F	std/tilt+IWS	1825/1865
G		270
H	std/tilt+IWS	780/820
I	std/tilt+IWS	380/420
K		435
L		425
M		525
N		660
O		2225
P		935
R		815
S		325
T		2200
U		1120
V		300

1	Control panel
2	Door opening \varnothing 535
3a	Five-compartment detergent box, front (optional)
3b	Five-compartment detergent box, right hand side (optional)
4	Cold water connection
5	Hot water connection
6	Third water connection (optional)
7	Steam connection
8	Drain
9	Electrical connection
10	Compressed air connection
11	External liquid detergent connections, 6 pcs \varnothing 10 mm, 1 pc \varnothing 16 mm and 1 pc \varnothing 20 mm
12	Water connection, detergent injector (optional) 3/4"

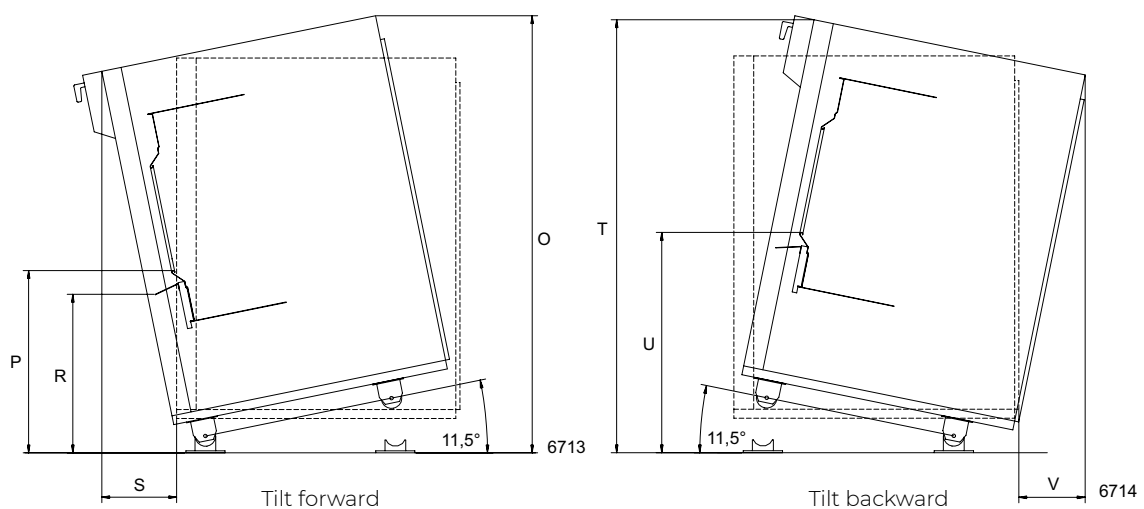
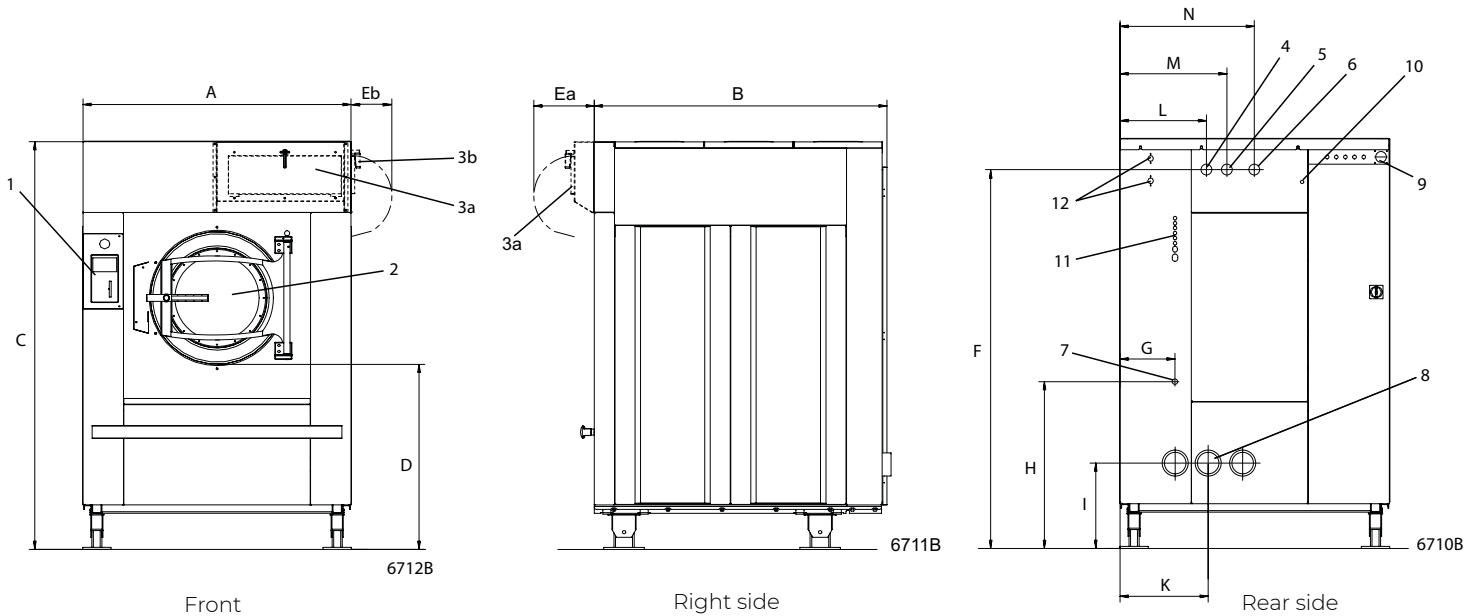

Options

- Front mounted loading hopper - easy loading from "sling-bag" system. Manually operated.
- Backwards and forwards tilting – backwards tilting can be used in conjunction with input wheel or other loading system.
- Forward tilting with drum reversal – makes unloading into a trolley easy.
- Five-compartment detergent box (5 x 1 litre) on right hand side or front.
- Third water valve – electrically-controlled water valve for hard water.
- Steam connection components.
- Connection components for 2 water connections.
- Connection components for 3 water connections.
- IS – Integrated Saving.
- Large water valves (DN 32 / 1 1/4" BSP).
- Kit for connection to CMIS (Certus Management Information Systems) network. CMIS provides vital statistics, error codes, maintenance intervals, process receipt, etc.

Accessory

- PC program. Allows the creation of wash programs on a PC and their transference to the machine via a memory card.



CMIS can be fitted to washer extractors with Clarus Control, tumble dryers with Selecta Control and ironers with electronic control system. All you need to access and view the statistical feedback is a normal PC.