

# Tumble dryer

## D7-130, D7-130C

### Features and benefits

- **Intelligent control offers:**
  - Large display and one control knob for easy program selection
  - Language selection
  - Quick start and option buttons for frequently used programs
  - Drying program packages optimized for Economy, Care and Time
  - Service program for adjustment of parameters
  - USB connection
- Moisture Control for an accurate drying result and a low energy consumption
- Reversing drum for less tangling of large items
- Stainless steel drum
- Reversible door hanging for a convenient laundry flow
- Easy access to vital parts from the top and rear for simple servicing
- The coin version with Ecopower to avoid over drying of the garments and get a lower energy consumption
- D7-130C: For optimal performance the room temperature should not exceed 25° Celcius



Images shown are a representation of the product only and variations may occur.

### Main options

- Stainless steel front
- Connection to booking- /payment- system or coin meter
- Stacking frame for mounting D7-130 on top of H7-55
- Stainless steel base frame
- Integrated condense system

Main specifications			D7-130	D7-130C
Rated capacity,	filling factor 1:22	kg/lb	6/13	6/13
Drum volume		litre	130	130
Drum diameter		mm	575	575
Heating alternatives				
electric		kW	5.1 / 3.2	3.0
<b>Consumption data*</b>				
Total time full load		min	32	55
Energy consumption full load		kWh	2.78	2.96
Evaporation		g/min	92.8	48
Energy kWh/litre water evaporated		kWh/l	0.94	1.00

\* At rated capacity 100% cotton load at 50% initial moisture dried to 0%.

Produced according to ISO 9001 and ISO 14001.

Certified with CB certificate for Low Voltage Directive and S-mark according to the Machinery Directive. Protection class IP X4D.

Electrical connections					
Heating alternative	Main voltage		Heating power kW	Total power kW	Recommended fuse A
		Hz			
Electric heated D7-130	220-230V 1 ~	50/60	3.1	3.3	16
	240V 1 ~	50/60	3.2	3.5	16
	220-230V 3 ~	50/60	3.1	3.3	16
	240V 3 ~	50/60	3.2	3.5	16
	220-230V 3 ~	50/60	4.9	5.1	16
	240V 3 ~	50/60	5.1	5.4	16
	380-400V 3 ~	50/60	4.9	5.1	10
	415V 3 ~	50/60	5.1	5.3	10
	440V 3 ~	60	5.1	5.4	10
	480V 3 ~	60	5.1	5.3	10
	D7-130C	380-400V 3N ~	50/60	4.9	5.1
440V 3 ~		60	3.0	3.4	10
380-400V 3N ~		50/60	3.0	3.3	10
220-230V 3 ~		50/60	2.9	3.3	10

Connections		D7-130	D7-130C
Air outlet	mm	ø 100	-
Maximum air flow	m <sup>3</sup> /h	240	-
Condensate		-	1/2"
Maximum static back pressure	Pa	80	-
Sound levels			
Sound power/pressure level at drying*			
	dB(A)	67/53	67/53
Heat emission			
% of installed power, max		15	15
Shipping data**			
Shipping volume	net, kg m <sup>3</sup>	58 0.51	57 0.63
Accessories			
Stacking frame for mounting D7-130 on top of H7-55		x	x
Stainless steel base frame		x	x
Dimensions in mm			
<b>A</b> Width		597	597
<b>B</b> Depth		725	725
<b>C</b> Height		839	839
<b>D</b>		138	138
<b>E</b>		50	50
<b>F</b>		89	89
<b>G</b>		200	200
<b>1</b> Operating panel <b>2</b> Door opening ø 370 mm <b>3</b> Electrical connection <b>4</b> Exhaust connection <b>5</b> Condense connection			

\* Sound power levels measured according to ISO 60704.

\*\* Average data. Crated weight/shipping volume depends on configuration. Please contact logistics for exact measures.

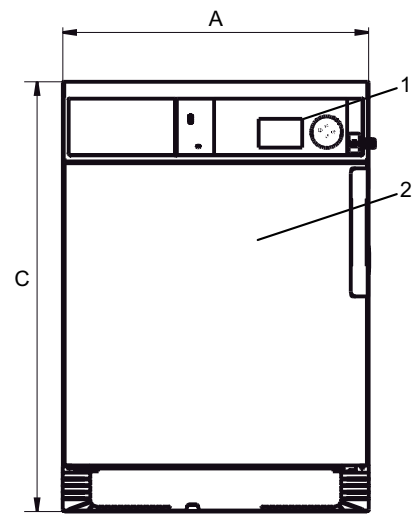

Front

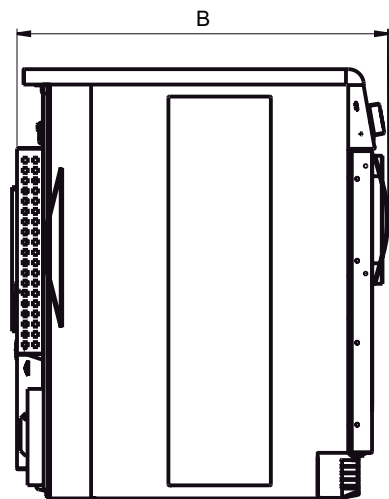

Left side

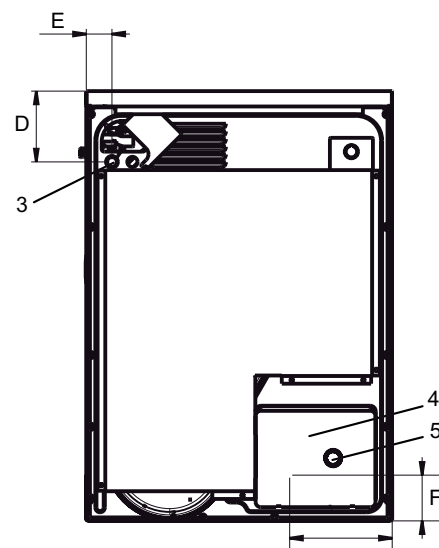

Rear side