

A	GENERAL INFORMATION	Page	7
A1	Introduction	Page	7
A2	Definitions	Page	7
A3	Typographical conventions	Page	7
A4	Machine and Manufacturer's identification data	Page	7
A5	Equipment identification	Page	8
	A5.1 How to identify the technical data	Page	8
	A5.2 How to interpret the factory description	Page	8
A6	Copyright	Page	8
A7	Liability	Page	8
A8	Personal protection equipment	Page	9
A9	Keeping the manual	Page	9
A10	Users of the manual	Page	9
B	GENERAL DESCRIPTION OF MACHINE	Page	10
B1	General description	Page	10
C	TECHNICAL DATA	Page	10
C1	Main technical characteristics	Page	10
C2	Characteristics of power supply	Page	11
D	TRANSPORT, HANDLING AND STORAGE	Page	12
D1	Introduction	Page	12
	D1.1 Transport: Instructions for the carrier	Page	12
D2	Handling	Page	12
	D2.1 Procedures for handling operations	Page	12
	D2.2 Translation	Page	12
	D2.3 Placing the load	Page	12
D3	Storage	Page	12
E	INSTALLATION AND ASSEMBLY	Page	13
E1	Customer responsibilities	Page	13
E2	Characteristics of the place of machine installation	Page	13
E3	Machine space limits	Page	13
E4	Positioning	Page	13
E5	Disposal of packing	Page	14
E6	Plumbing connections	Page	14
	E6.1 Plumbing circuits	Page	14
	E6.2 Installation diagrams	Page	15
E7	Electrical connections	Page	18
E8	Energy control arrangement	Page	18
E9	HACCP arrangement	Page	19
F	DESCRIPTION OF CONTROL PANEL	Page	20
F1	Basic controls	Page	21
G	STARTING	Page	22
G1	Preliminary checks, adjustments and operational tests	Page	22
	G1.1 Electrical and plumbing checks	Page	22
	G1.2 Check the positioning of tank components	Page	22

	G1.2.1	Check the fitting of filters and overflows.....	Page	22
	G1.2.2	Arm fitting check.....	Page	22
G2		Starting	Page	22
G3		Detergent/rinse-aid dispensers and settings	Page	22
G4		Setting the dispensers	Page	23
H		GENERAL SAFETY RULES.....	Page	26
H1		Introduction	Page	26
	H1.1	Protection devices installed on the machine	Page	26
		H1.1.1 Guards	Page	26
	H1.2	Safety signs to be displayed on the machine or near the work area	Page	26
H2		Decommissioning	Page	26
H3		Instructions for use and maintenance.....	Page	26
H4		Improper use.....	Page	27
H5		Residual risks	Page	27
I		NORMAL MACHINE USE.....	Page	28
I1		Correct use	Page	28
I2		Characteristics of personnel enabled to operate on the machine.....	Page	28
I3		First use	Page	28
I4		Daily activation of machine	Page	28
I5		Wash cycles.....	Page	28
I6		Operation	Page	29
I7		Alarms.....	Page	30
I8		Machine cleaning.....	Page	31
	I8.1	End of service and daily internal cleaning	Page	31
	I8.2	Exterior cleaning.....	Page	31
I9		Long idle periods	Page	32
I10		Maintenance	Page	32
	I10.1	Preventive maintenance	Page	32
I11		Machine disposal	Page	32
I12		Troubleshooting	Page	32

INDEX OF FIGURES

Figure 1	Reproduction of the marking/dataplate on the machine.....	Page	7
Figure 2	Position of marking.....	Page	8
Figure 3	Technical data identification.....	Page	8
Figure 4	Example of document identification data.	Page	8
Figure 5	Unpacking	Page	13
Figure 6	Machine positioning	Page	13
Figure 7	Removing the film	Page	13
Figure 8	Feet adjustment	Page	13
Figure 9	Machine fixing clamp.....	Page	14
Figure 10	Feed pipe connection.....	Page	14
Figure 11	4380-415V 3N.....	Page	18
Figure 12	220-240V 3	Page	18
Figure 13	220-240V 1N.....	Page	18
Figure 14	Energy control.....	Page	18
Figure 15	HACCP connection position.....	Page	19
Figure 16	Filters and overflow	Page	22
Figure 17	Wash and rinse arms	Page	22
Figure 18	Automatic dispenser arrangement	Page	23
Figure 19	Detergent dispenser terminal block.....	Page	23
Figure 20	Rinse aid dispenser terminal block	Page	23
Figure 21	YELLOW rack	Page	30
Figure 22	GREEN rack.....	Page	30
Figure 23	BLUE rack for glasses.....	Page	30
Figure 24	YELLOW container for cutlery.....	Page	30
Figure 25	Filters and overflow	Page	31
Figure 26	Wash and rinse arms	Page	31

INDEX OF TABLES

Table 1	Main technical characteristics, performance and consumption.....	Page	10
Table 2	Control panel.....	Page	20
Table 3	Residual risks.....	Page	27

Foreword

The instruction manual (hereinafter Manual) provides the operator with useful information for working correctly and safely, facilitating him in using the machine (hereinafter “machine”, “dishwasher” or “equipment”).

The following must not be considered a long and exacting list of warnings, but rather a set of instructions suitable for improving machine performance in every respect and, above all, preventing injury to persons and animals and damage to property due to improper operating procedures.

All persons involved in machine transport, installation, starting, use and maintenance, repair and dismantling must consult and carefully read this manual before performing the various operations, for the purpose of avoiding wrong and improper actions that could negatively affect the machine’s integrity or endanger persons.

The manual must always be available to operators and carefully kept in the place where the machine is used so that it is immediately at hand for consultation in case of doubts or whenever required.

If, after reading this manual, there are still doubts regarding machine use, do not hesitate to contact the Manufacturer, or the authorized assistance centre, to receive prompt and precise assistance for better operation and maximum efficiency of the machine.

During all phases of machine use, always respect the current regulations on safety, work hygiene and environmental protection. It is the user’s responsibility to make sure the machine is started and operated only in optimal safety conditions for persons, animals and property.

This appliance is not intended for use by people (including children) with limited physical, sensory or mental abilities or without experience and knowledge of it, unless they are supervised or instructed in its use by a person responsible for their safety.

Children must be supervised to make sure they do not play with the equipment.

A GENERAL INFORMATION

A1 Introduction

This chapter describes the symbols used (that mark and identify the type of warning) and gives the definitions of terms used in the manual, responsibilities and copyright.

A2 Definitions

Listed below are the definitions of the main terms used in the Manual. Carefully read them before using the Manual.

Operator

an operator who carries out machine installation, adjustment, use, maintenance, cleaning, repair and transport.

Manufacturer

Electrolux Professional S.p.A. or any other assistance centre authorized by Electrolux Professional S.p.A..

Operator qualified for normal machine use

an operator who has been informed, instructed and trained regarding the tasks and hazards involved in normal machine use.

Specialized technician or Technical assistance

an operator instructed/trained by the Manufacturer and who, based on his professional and specific training, experience and knowledge of the accident-prevention regulations, is able to appraise the operations to be carried out on the machine and recognize and prevent possible risks. His professionalism covers the mechanical, electrotechnical and electronics fields.

Danger

source of possible injury or harm to health.

Hazardous situation

any situation where an operator is exposed to one or more hazards.

Risk

a combination of probabilities and risks of injury or harm to health in a hazardous situation.

Guards

safety measures consisting of the use of specific technical means (guards and safety devices) for protecting operators against dangers.

Guard

an element of a machine used specifically to provide protection by means of a physical barrier.

Safety device

a device (other than a guard) that eliminates or reduces the risk; it can be used alone or in combination with a guard.

Customer

the person who purchased the machine and/or who manages and uses it (e.g. company, entrepreneur, firm).

Emergency stop device

a group of components intended for the emergency stop function; the device is activated with a single action and prevents or reduces damage to persons/machines/property/animals.

Electrocution

an accidental discharge of electric current on a human body.

A3 Typographical conventions

For best use of the manual, and therefore the machine, it is advisable to have good knowledge of the terms and typographical conventions used in the documentation.

The following symbols are used in the manual to mark and identify the various types of hazards:



WARNING!

DANGER FOR THE HEALTH AND SAFETY OF OPERATORS.



WARNING!

DANGER OF ELECTROCUTION - DANGEROUS VOLTAGE.

Machine guards and protection devices marked with this symbol must only be opened by qualified personnel, after disconnecting the power to the machine.



WARNING!

DANGER OF DAMAGE TO THE MACHINE.

Words and safety warnings further explaining the type of hazard are placed next to the symbols in the text. The warnings are intended to guarantee the safety of personnel and prevent damage to the machine or the product being worked.

The drawings and diagrams given in the manual are not in scale. They supplement the written information with an outline, but are not intended to be a detailed representation of the machine supplied.

The numerical values given in the machine installation diagrams refer to measurements expressed in mm (see paragraph E6.2 "Installation diagrams").

A4 Machine and Manufacturer's identification data

A reproduction of the marking or dataplate on the machine is given below.

F.Mod.	EHT8ROW	Comm. Model	EHT8ROW	2012
PNC	9CGX 505073 00	Ser.Nr.	22006001	
EL	AC 400V 3N	50 Hz	Max	12.9 kW
	(AC 230 V / 1+N / 50 Hz; 230 V / 3 / 50 Hz)	Default		9.9 kW
				IP25 
Electrolux Professional spa - Viale Treviso, 15 - 33170 Pordenone (Italy)				

Figure 1 Reproduction of the marking/dataplate on the machine.

The dataplate gives the product identification and technical data; the meaning of the information given on it is listed below.

F.Mod factory description of the product
 Comm. Model trade description
 PNC production code number
 Ser. Nr. serial number
 AC 400V 3N power supply voltage
 (AC 230 V / 1+N / 50 Hz;
 230 V / 3 / 50 Hz) ... electric convertibility
 50 Hz power supply frequency
 Max 12.9 kW max. power absorbed
 Nominal 9.9 kW power absorbed as factory setting
 2014 year of construction
 CE CE marking
 IP25 protection rating
 Electrolux Professional spa - Viale Treviso, 15 -33170
 Pordenone (Italy) Manufacturer

The marking plate is located on the right side panel of the equipment.

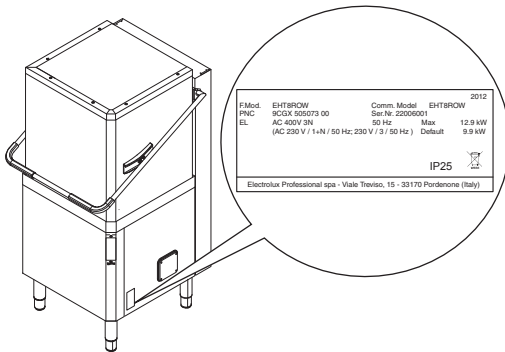

Figure 2 Position of marking



WARNING!

Do not remove, tamper with or make the machine marking illegible.



IMPORTANT!

Refer to the data given on the machine marking for relations with the Manufacturer (e.g. when ordering spare parts, etc.).



IMPORTANT!

When disposing of the machine the marking must be destroyed.

A5 Equipment identification

A5.1 How to identify the technical data

To identify the technical data (Figure 3) read the factory description of the product (F.Mod.) on the dataplate, identify the main machine data and consult the Table 1 “Main technical characteristics, performance and consumption”.

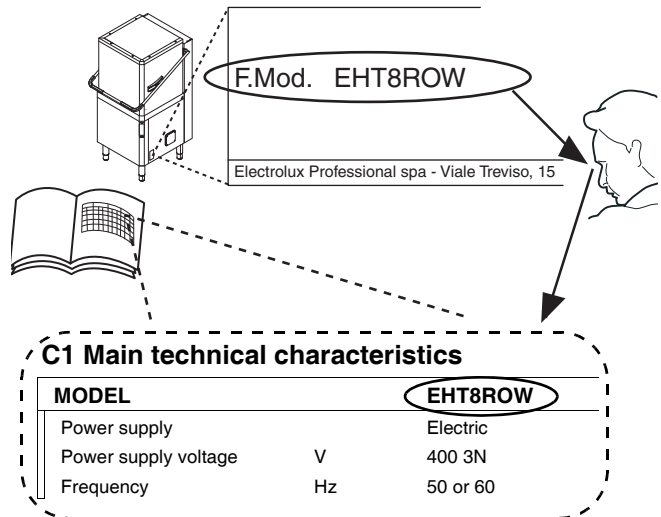

Figure 3 Technical data identification

A5.2 How to interpret the factory description

The factory description on the dataplate has the following meaning (some examples are given below):

Single-skin hood version							
(1)	(2)	(3)	(4)	(5)	(6)	(7)	(8)
N	HT	8	R	O	W		
E	HT	8	O				
Z	HT	8	R	O	W	6	

Double-skin hood version							
(1)	(2)	(3)	(4)	(5)	(6)	(7)	(8)
Z	HT	8	I	R	O	W	
E	HT	8	I	R	O	W	6

Variables description	
(1) Mark	N = To brand, Z = Zanussi, E = Electrolux.
(2) Machine type	HT = Hood type
(3) Racks/h	8 = capacity 80 racks/h
(4).. (8)	I = double-skin hood, ROW = for Asia + India + Latin America market, O = for Middle East market, 6 = 60 Hz.

A6 Copyright

This manual is intended for consultation only by the operator and can be given to third parties only with the written permission of Electrolux Professional S.p.A..

A7 Liability

The instructions are updated to the month and year given in the box located at the bottom right of the cover. The edition corresponds to the manual revision number. Every new edition replaces and cancels the previous ones.

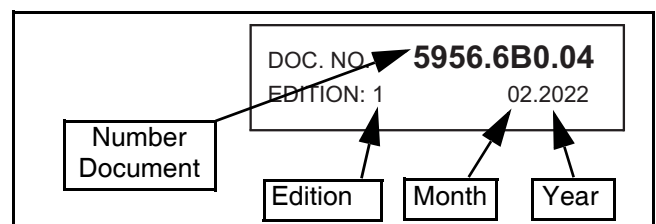

Figure 4 Example of document identification data.

The Manufacturer declines any liability for damage and malfunctioning caused by:

- non-compliance with the instructions contained in this manual;
- repairs not carried out in a workmanlike fashion, and replacements using spare parts different from those specified in this manual (the fitting and use of non-original spare parts and accessories can negatively affect machine operation);
- operations by non-specialized technicians;
- unauthorized modifications or operations;
- inadequate maintenance;
- improper machine use;
- unexpected extraordinary events;
- use of the machine by uninformed and untrained personnel;
- non-application of the current provisions in the country of use, concerning safety, hygiene and health in the workplace.

The Manufacturer declines any liability for damage caused by arbitrary modifications and conversions carried out by the user or the Customer.





The employer or workplace manager is responsible for identifying and choosing adequate and suitable personal protection equipment to be worn by operators, in compliance with current regulations in the country of use.

Electrolux Professional S.p.A. declines any liability for possible inaccuracies contained in the manual, if due to printing or translation errors.

Any supplements to the instruction manual the Customer receives from the Manufacturer must be kept together with the manual, of which they will form an integral part.

A8 Personal protection equipment

Give below is a summary table of the Personal Protection Equipment (PPE) to be used during the various stages of the machine's service life.

Stage	Protective garments 	Safety footwear 	Gloves 	Glasses 	Safety helmet 
Transport	—	●	○	—	○
Handling	●	●	○	—	—
Unpacking	○	●	○	—	—
Assembly	○	●	○	—	—
Normal use	●	●	● (1)	○	—
Adjustments	○	●	—	—	—
Routine cleaning	○	●	● (1)	○	—
Extraordinary cleaning	○	●	● (1)	○	—
Maintenance	○	●	○	—	—
Dismantling	○	●	○	—	—
Scrapping	○	●	○	—	—

Key:

●	PPE REQUIRED
○	PPE AVAILABLE OR TO BE USED IF NECESSARY
—	PPE NOT REQUIRED

(1) Use heat resistant gloves suitable for contact with water and the substances used (see the safety data sheet of the substances used to check other possible PPE).

Failure to use the personal protection equipment by operators, specialised technicians or users can involve exposure to chemical risk and possible damage to health.

A9 Keeping the manual

The manual must be carefully kept for the entire life of the machine until decommissioning.

The manual must stay with the machine in case of transfer, sale, hire, granting of use or leasing.

A10 Users of the manual

This manual is intended for:

- the carrier and handling personnel;
- installation and start-up personnel;
- the employer of machine users and the workplace manager;
- operators in charge of normal machine use;
- specialized technicians - technical assistance (see wiring diagram and service manual).

B GENERAL DESCRIPTION OF MACHINE

B1 General description

The dishwasher is suitable for washing dishes, glasses, cups, cutlery, trays, containers and receptacles in plastic and/or steel used for preparing, cooking and serving; as well as various cooking utensils in ceramic and/or metal.

The machine is designed for the above-mentioned applications. Under no circumstances may the machine be used for other applications or ways not provided for in this manual.

This equipment has been produced to meet the needs for a better work environment and economical efficiency. These dishwashers are used in restaurants, cafeterias, cooking centres and large institutions.

The special dish racks, that can be equipped with various inserts, offer practical and easy use for obtaining excellent washing results. The electronic system enables complete supervision of the washing process. The control panel also has a display that shows the operating parameters and signals any anomalies.

Systems for scraping and wetting the dishes (e.g. manual prewash spray) and areas for sorting and arranging them in the racks must be arranged ahead of the dishwasher.

C TECHNICAL DATA

C1 Main technical characteristics

MODEL		NHT8ROW/ NHT8O/EHT8ROW/ EHT8O/ZHT8ROW/ ZHT8O	NHT8O6/ NHT8ROW6/EHT8O6/ ZHT8ROW6/ZHT8O6	ZHT8IROW/ EHT8IROW	ZHT8IROW6/ EHT8IROW6	EHT8ROW6
Supply voltage:	V	400V 3N	380-400V 3N	400V 3N	380-400V 3N	220-230V 3
- convertible to	V	230V 3	220-230V 3	230V 3	220-230V 3	380-400V 3N
- convertible to	V	230V 1N	220-230V 1N	230V 1N	220-230V 1N	220-230V 1N
Frequency	Hz	50	60	50	60	60
Max. power. absorbed	kW	12,9 (*)	12,9 (*)	12,9 (*)	12,9 (*)	12,9 (*)
power absorbed <u>as factory setting</u>	kW	9,9	9,9	9,9	9,9	9,9
Boiler heating elements	kW	9,0	9,0	9,0	9,0	9,0
Tank heating elements	kW	3,0	3,0	3,0	3,0	3,0
Water supply pressure	kPa [bar]	50-700 [0,5-7]	50-700 [0,5-7]	50-700 [0,5-7]	50-700 [0,5-7]	50-700 [0,5-7]
Water supply temperature	°C	10 - 65	10 - 65	10 - 65	10 - 65	10 - 65
Water supply hardness	°f/°d/°e	14/8/10 max	14/8/10 max	14/8/10 max	14/8/10 max	14/8/10 max
Electric conductivity of water	µS/cm	< 400	< 400	< 400	< 400	< 400
Concentration of chlorides in water	ppm	< 20	< 20	< 20	< 20	< 20
Rinse cycle water consumption	l	2,0	2,0	2,0	2,0	2,0
Boiler capacity	l	12	12	12	12	12
Tank capacity	l	24	24	24	24	24
Cycle duration in High Productivity mode	sec.	45(**)-84-150	45(**)-84-150	45(**)-84-150	45(**)-84-150	45(**)-84-150
Cycle duration in NSF/Ansi 3 compliant mode	sec.	57(**)-84-150	57(**)-84-150	57(**)-84-150	57(**)-84-150	57(**)-84-150
Legal noise level Leq	dB(A)	<68	<68	<63	<63	<68
Protection rating		IP25	IP25	IP25	IP25	IP25
Net weight	kg	106	106	117	117	106
Power supply cable		H07RN-F	H07RN-F	H07RN-F	H07RN-F	H07RN-F
Supply cord diameter (min. - max. value)	mm	18 - 25	18 - 25	18 - 25	18 - 25	18 - 25
Latent heat	kWh	0,5	0,5	0,5	0,5	0,5
Sensible heat	kWh	2	2	2	2	2

(*) = If activated by software, coincidence of tank and boiler heating elements.
(**) = With water supply temperature at 65°C / 149°F.
Standard cycle time may vary should the inlet water temperature be different from that indicated above.

Table 1 Main technical characteristics, performance and consumption

	380-415V 3N		220-240V 3		220-240V 1N	
	C	S	C	S	C	S
9,9 kW	5X2,5 mm ²	20A 3P+N	4X6 mm ²	32A 3P	3X10 mm ²	60 A 1P+N
12,9 kW	5X4 mm ²	32A 3P+N	4X10 mm ²	50A 3P	3X10 mm ²	70 A 1P+N

C = Power supply cable
S = On/Off switch

C2 Characteristics of power supply

The AC power supply to the machine must meet the following conditions:

- max. voltage variation $\pm 10\%$
- max. frequency variation $\pm 1\%$ continuous $\pm 2\%$ for a short period.

Harmonic distortion, unbalanced three-phase supply voltage, voltage pulses, interruption, dips and the other electric characteristics must respect the provisions of point 4.3.2 of Standard EN 60204-1 (IEC 60204-1).



IMPORTANT!

The machine's power supply must be protected against overcurrents (short circuits and overloads) by fuses or suitable thermal magnetic circuit breakers.

These must be fitted on an omnipolar disconnection system having a contact gap of at least 3 mm.



IMPORTANT!

For protection against indirect contacts (depending on the type of supply provided for and connection of earths to the equipotential protection circuit) refer to point 6.3.3 of EN 60204-1 (IEC 60204-1) with the use of protection devices that ensure automatic cut-off of the supply in case of isolation fault in the TN or TT systems or, for IT systems, the use of isolation controllers or differential current protection devices to activate automatic power disconnection (an isolation controller must be provided for indicating a possible first earth fault of a live part, unless a protection device is supplied for switching off the power in case of a such a fault. This device must activate an acoustic and/or visual signal which must continue for the entire duration of the fault).

For example: in a TT system, a differential switch with cut-in current (e.g. 30 mA) coordinated with the earthing system of the building where the machine is located must be installed ahead of the supply.



IMPORTANT!

Customers are requested to follow these instructions, otherwise the Manufacturer does not guarantee the machine for continuous operation and/or against faults.

D TRANSPORT, HANDLING AND STORAGE

D1 Introduction

Transport (i.e. transfer of the machine from one place to another) and handling (i.e. transfer inside work-places) must occur with the use of special equipment of adequate capacity.

The machine must only be transported, handled and stored by qualified personnel, who must have:

- specific technical training and experience;
- knowledge of the safety regulations and applicable laws in the relevant sectors;
- knowledge of the general safety provisions;
- the ability to recognize and avoid any possible hazard.

D1.1 Transport: Instructions for the carrier



WARNING!

Do not stand under suspended loads during the loading/unloading phases. Unauthorized personnel must not access the work zone.



IMPORTANT!

The machine's weight alone is not sufficient to keep it steady.

The transported load can shift:

- when braking;
- when accelerating;
- in corners;
- on particularly rough roads.

D2 Handling

Arrange a suitable area with flat floor for machine unloading and storage operations.

D2.1 Procedures for handling operations

For correct and safe lifting operations:

- use the type of equipment most suitable for characteristics and capacity (e.g. lift trucks or electric pallet truck);
- cover sharp edges;
- check the forks and lifting procedures according to the instructions given on the packing.

Before lifting:

- send all operators to a safe position and prevent persons from accessing the handling zone;
- make sure the load is stable;
- make sure no material can fall during lifting, and manoeuvre vertically in order to avoid impacts;
- handle the machine, keeping it at minimum height from the ground.



CAUTION!

For machine lifting, do not use movable or weak parts such as casings, electrical raceways, pneumatic parts, etc., as anchoring points.

D2.2 Translation

The operator must:

- have a general view of the path to be followed;
- stop the manoeuvre in case of hazardous situations.

D2.3 Placing the load

Before placing the load make sure the path is free and that the floor is flat and can take the load.

D3 Storage

The machine and/or its parts must be stored and protected against damp, in a non-aggressive place free of vibrations and with room temperature of between -10°C and 50°C.

The place where the machine is stored must have a flat support surface in order to avoid any twisting of the machine or damage to the support feet.



IMPORTANT!

Machine positioning, installation and disassembly must be carried out by a specialized technician.



IMPORTANT!

Do not make modifications to the parts supplied with the machine. Any missing or faulty parts must be replaced with original parts.

E**INSTALLATION AND ASSEMBLY****IMPORTANT!**

Machine installation operations must only be carried out by specialized Technicians provided with all the appropriate personal protection equipment (safety shoes, gloves, glasses, overalls, etc.), tools, utensils and ancillary means.

E1 Customer responsibilities

The Customer must provide for the following:

- Install a disconnecting switch with a capacity at least equal to that given in the technical data table, a 30mA residual current circuit breaker and an overcurrent device (magnetothermal cut-out with manual reset or fuse) between the appliance and the mains power outlet. The chosen device must be lockable in the open position in case of maintenance.
- install an adequate electrical power supply ahead of the machine, according to the equipment's technical specifications (Table 1 and C2 "Characteristics of power supply");
- the equipotential connection of the workplace electrical system to the metal structure of the machine by means of a copper cable of adequate section (see position "EQ" in par. E6.2 "Installation diagrams");
- Adducting for the electrical connection between the workplace electric panel and the equipment;
- the water supply and drain connections and other connections as indicated in Table 1 and par. E6 "Plumbing connections";

E2 Characteristics of the place of machine installation

The machine is designed for installation in professional and not domestic-type kitchens. Water collection traps/ metal grates must be arranged in the floor at the machine discharges (see paragraph E6.2 "Installation diagrams"), possibly replaceable with a single water trap sized for a flow rate of at least 3 l/s.

E3 Machine space limits

A suitable space must be left around the machine (for operations, maintenance, etc.).

The passages enabling personnel to operate on the machine must be at least 50 cm wide, except at the rear of the machine.

The size must be increased in case of use and/or transfer of other equipment and/or means or if exit routes are necessary inside the workplace.

E4 Positioning

The machine must be taken to the place of installation and the packing base removed only when being installed.

IMPORTANT

Do not place the dishwasher near direct heat sources such as fryers, ovens, hot-plates, etc.

Arranging the machine:

- Wear protective gloves and unpack the machine (Figure 5).

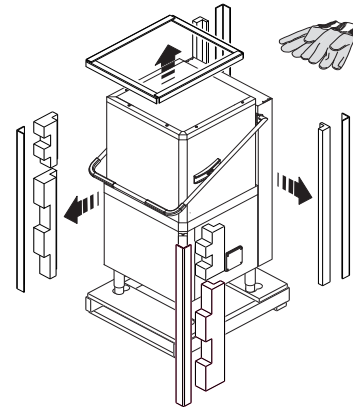

Figure 5 Unpacking

- Lift the appliance using a lift truck, remove the base and position the appliance where it is to be installed (Figure 6).

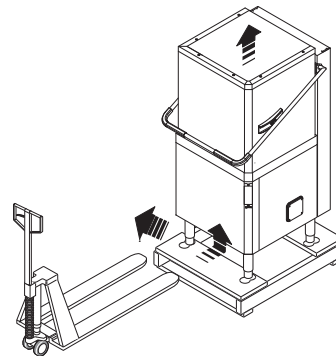

Figure 6 Machine positioning

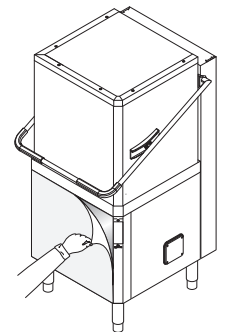

Figure 7 Removing the film

- Carefully remove the protective film from the outer panels without tearing it, to avoid leaving traces of glue (Figure 7).
- Adjust the equipment by turning the special adjustable feet and making sure it is perfectly level, both lengthwise and crosswise (Figure 8).

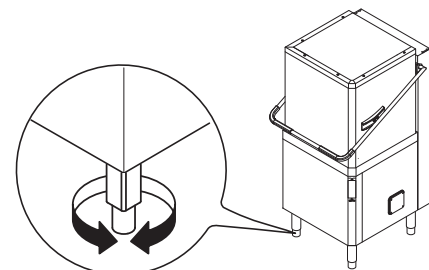

Figure 8 Feet adjustment

- The appliance must be fixed to the floor using the two clamps supplied (Figure 9).

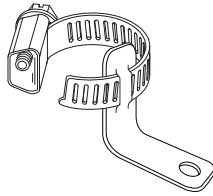

Figure 9 Machine fixing clamp

- Accessing the appliance bottom panel.
- Fit the clamps on feet as shown in supplied technical sheet.
- Screw the appliance steadily to the floor using hole clamps.

E5 Disposal of packing

All materials used for packing are environmentally compatible. They can be safely kept, and recycled or burnt in a special waste incineration plant. Plastic parts subject to possible recycling are marked as follows:

- | | | |
|--|--------------------------|---|
| | polyethylene: | outer wrapping, instruction booklet bag. |
| | polypropylene: | roof packing panels, straps. |
| | polystyrene foam: | corner protectors. |

Parts in wood and cardboard can be disposed of respecting the current regulations in the country of use.

E6 Plumbing connections

IMPORTANT

Watermark labelled appliances must be installed in accordance with Plumbing Code of Australia (PCA).

Install the machine water filling and drain pipes according to the plumbing circuit and installation diagrams given below.

- Connect the appliance water supply pipe "WI" (see paragraph E6.2 Installation diagrams) to the mains, fitting a cut-off valve, the filter provided and a pressure gauge between the appliance and the mains (Figure 10).

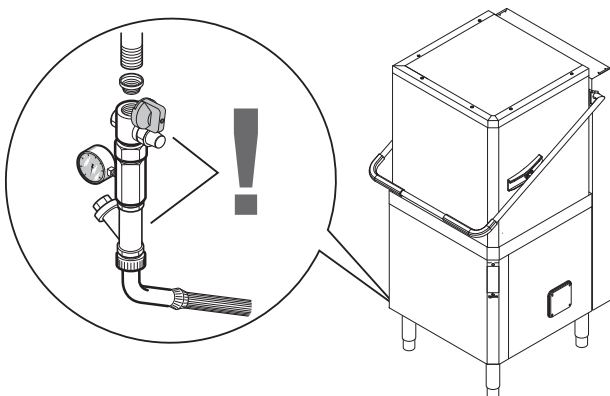
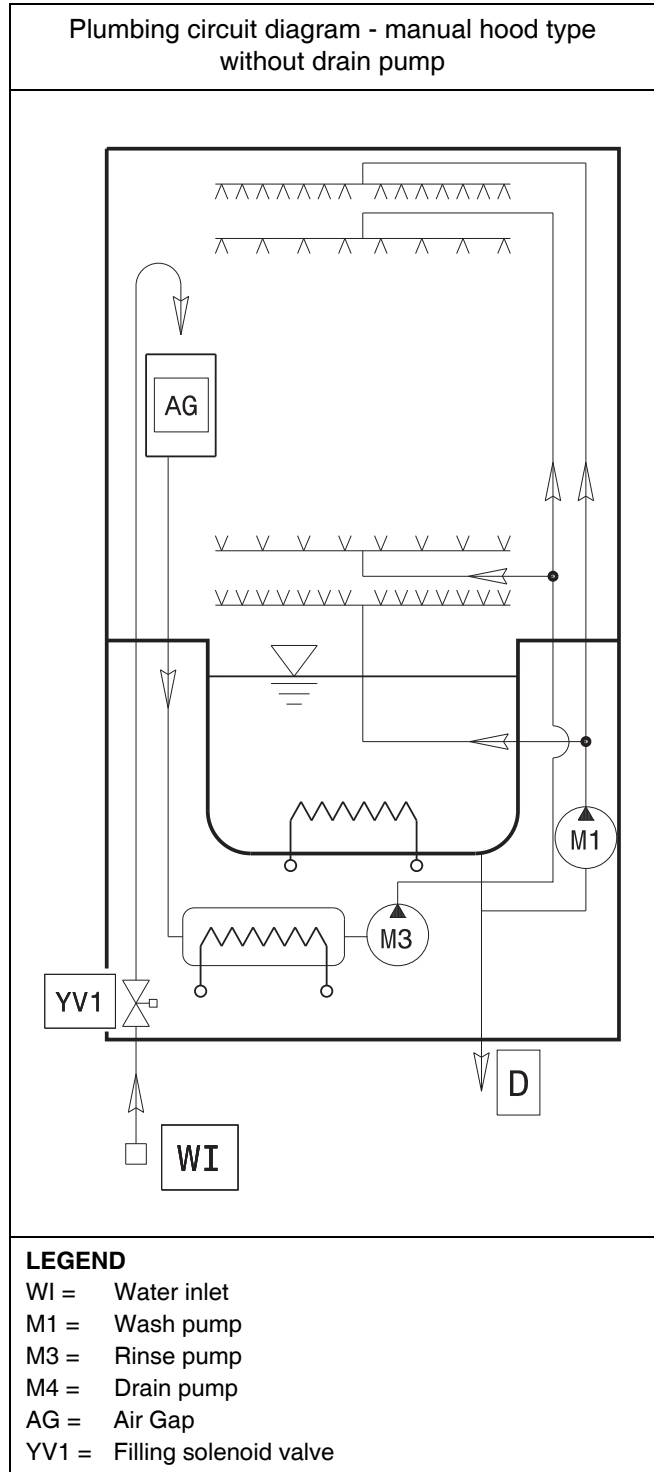

Figure 10 Feed pipe connection

- Check that the **dynamic** water supply **pressure**, measured between the appliance and the main, is **between 50 and 700 kPa** (test while dishwasher tank or boiler is filling with water).
If the pressure is too high, fit a suitable pressure reducer on the inlet pipe.
- Connect the waste outlet pipe "D" (see paragraph E6.2 Installation diagrams) to the main drain pipe, fitting a trap, or place the outlet pipe over an S trap set into the floor.

E6.1 Plumbing circuits



Plumbing circuit diagram - manual hood type with drain pump

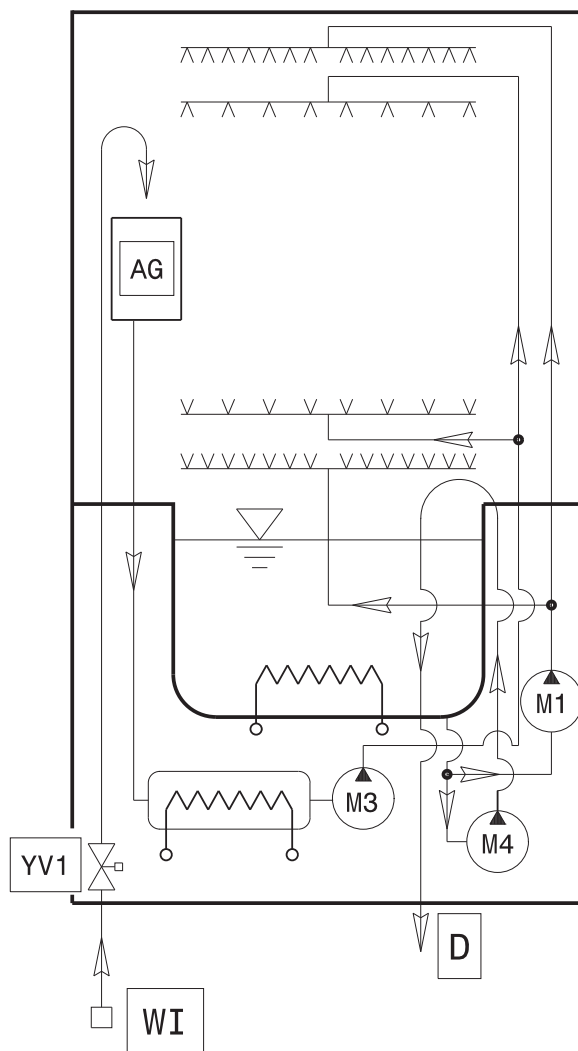

LEGEND

WI = Water inlet
 M1 = Wash pump
 M3 = Rinse pump

M4 = Drain pump
 AG = Air Gap
 YV1 = Filling solenoid valve

E6.2 Installation diagrams

The following installation diagrams give the machine overall dimensions and position of water and electrical connections.



IMPORTANT!

Make sure to install an extractor hood to remove the steam produced by the machine. The hood air flow must be calculated taking into account the type of installation and the work environment where it is installed. In any case, an air flow rate of between 1000 m³/h and 1500 m³/h is recommended.

Installation diagram - manual hood type (single skin) without drain pump

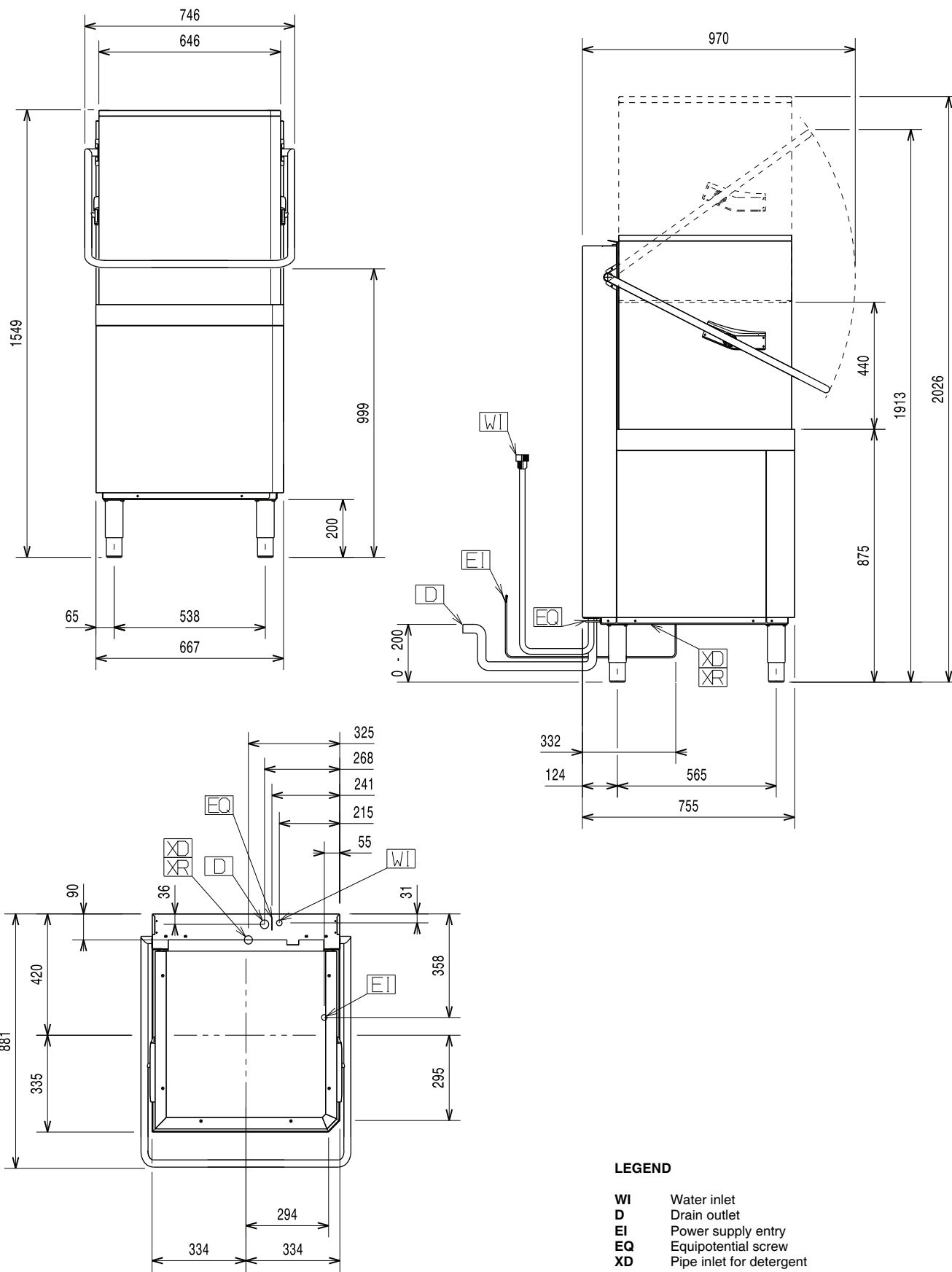

LEGEND

- WI** Water inlet
- D** Drain outlet
- EI** Power supply entry
- EQ** Equipotential screw
- XD** Pipe inlet for detergent
- XR** Pipe inlet for rinse aid

Installation diagram - manual hood type (double skin) with drain pump

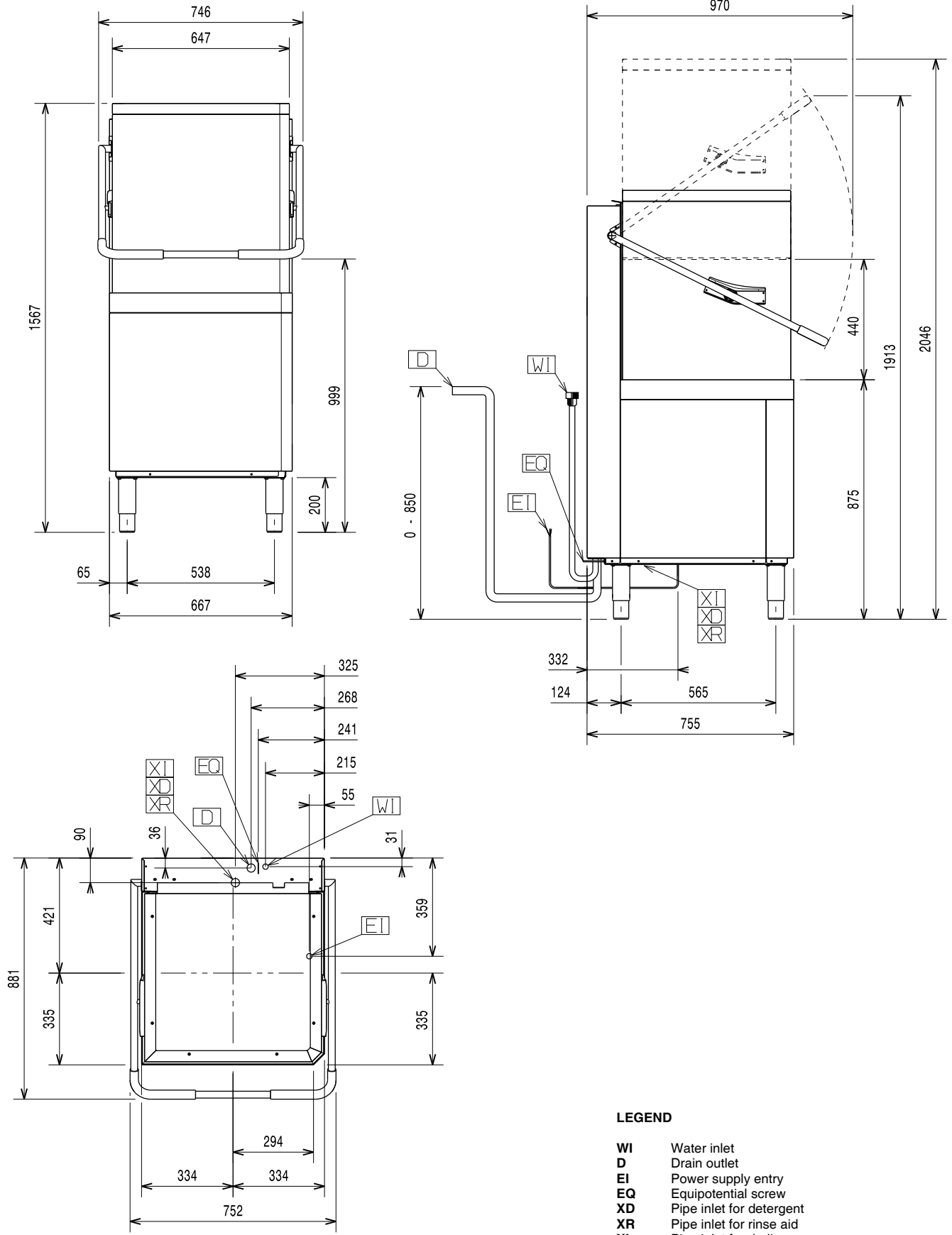

LEGEND

- WI** Water inlet
- D** Drain outlet
- EI** Power supply entry
- EQ** Equipotential screw
- XD** Pipe inlet for detergent
- XR** Pipe inlet for rinse aid
- XI** Pipe inlet for de-lime

E7 Electrical connections

Connection to the power supply must be carried out in conformity with the current regulations and provisions in the country of use.



IMPORTANT!

Work on the electrical systems must only be carried out by a qualified electrician.

- Make sure the machine power supply voltage specified on the rating plate (Table 1) matches the mains voltage.
- Make sure the system power supply is arranged and able to take the actual current load and that it is executed in a workmanlike manner according to the regulations in force in the country of use.
- The earth wire at the terminal end must be longer (max. 20 mm) than the phase wires.
- Connect the earth wire of the power supply cable to an efficient earth clamp. The appliance must also be included in a unipotential system, the connection being made through the screw "EQ" (see paragraph E6.2 Installation diagrams) marked with the symbol "⚡". The unipotential wire must have a cross section of 10 mm².

Power supply 380-415V 3N (standard configuration)

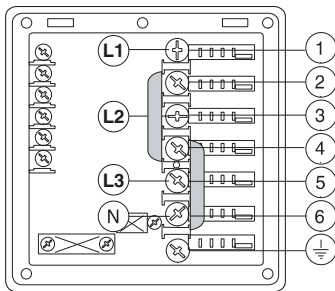

Figure 11 4380-415V 3N

Open the power supply terminal board and insert the jumpers provided as follows: two jumpers between terminals 2 and 4 and two between terminals 4 and 6.

Using a suitable power supply cable (see technical data table), connect the three phases to terminals 1, 3 and 5, the neutral to terminal 6 and the earth wire to the terminal ⚡.

Power supply 220-240V 3

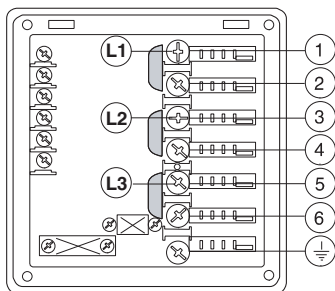

Figure 12 220-240V 3

Open the power supply terminal board and insert the jumpers provided as follows: one jumper between terminals 1 and 2, one between terminals 3 and 4 and another between terminals 5 and 6. Using a suitable power supply cable (see technical data table), connect the three phases to terminals 1, 3 and 5 and the earth wire to the terminal ⚡.

Power supply 220-240V 1N

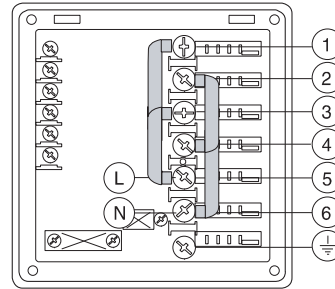

Figure 13 220-240V 1N

Open the power supply terminal board and insert the jumpers provided as follows: two jumpers between terminals 1 and 3, two jumpers between terminals 2 and 4, one jumper between terminals 3 and 5 and another two between terminals 4 and 6.

Using a suitable power supply cable (see technical data table), connect the phase and neutral to terminals 5 and 6 respectively and the earth wire to the terminal ⚡.

E8 Energy control arrangement

The machine is arranged for external control of energy consumption.

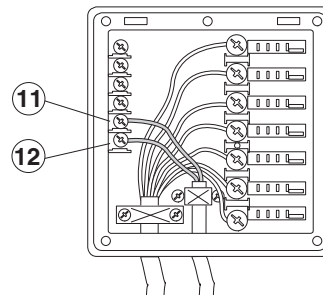

Figure 14 Energy control

Connect the energy peak controller across terminals 11 and 12 (Figure 14).



CAUTION

A normally open (n.o.) contact of the controller must be connected across terminals 11 and 12. When this contact closes the boiler heating elements are disconnected. Using the dishwasher in these conditions may increase the cycle time.

Safety devices

- An automatic reset thermoamperometric protective device incorporated in the windings of the electric

pump cuts off the electricity supply in the case of malfunctioning.

- In the event of water mains failure, a device prevents water in the boiler from returning into the mains.
- An overflow pipe, connected to the drainage outlet, maintains the water in the tank at a constant level.

Failure to comply with safety rules and regulations relieves the manufacturer of all liability.

E9 HACCP arrangement

In some models the machine is not arranged for the HACCP connection; however, an HACCP kit can be ordered as an accessory.

When the machine is arranged for the HACCP connection it is still necessary to order the network connection cable.

Connect the HACCP network to terminals 2 and 3 of connector X4.

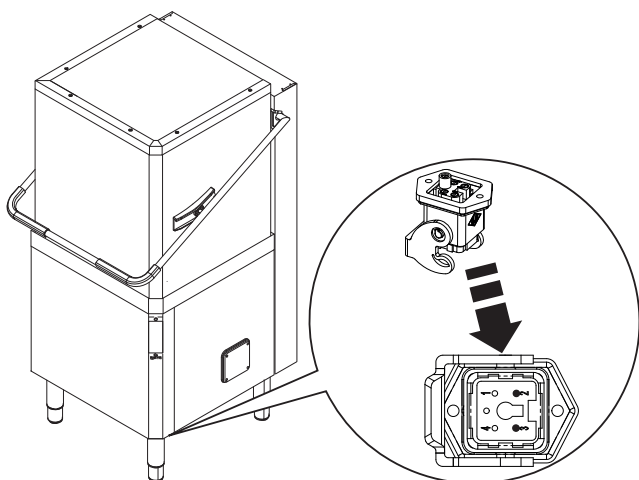
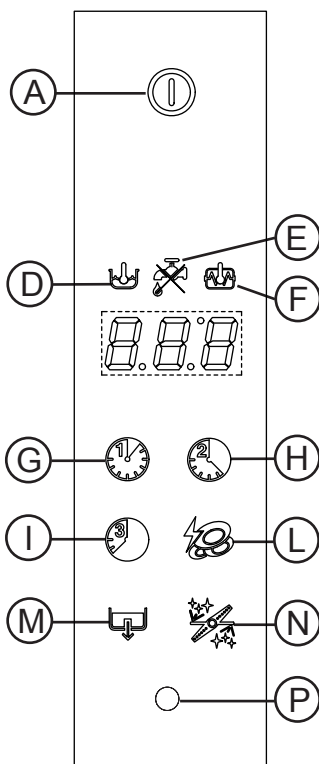

Figure 15 HACCP connection position

F DESCRIPTION OF CONTROL PANEL



Legend

A = On / Off	G = Wash cycle 1	N = Delime cycle
D = "Tank temperature" indicator light	H = Wash cycle 2	P = ACTIVE/ WASH SAFE CONTROL
E = "Water tap" indicator light	I = Wash cycle 3	
F = "Boiler temperature" indicator light	L = High Productivity or NSF/Ansi 3 compliant	
	M = Drain / self-cleaning cycle	

IMPORTANT

The **GUARANTEED RINSE SYSTEM (GRS)** is incorporated in the **ACTIVE/ WASH SAFE CONTROL** models (see led "P"). The GRS is an automatic rinse time/temperature control system.

Operation is as follows:

- during the wash cycle the indicator light is **OFF**;
- during the rinse cycle the indicator light comes on and is **GREEN**;
- at the end of the rinse cycle the indicator light remains **GREEN** if the rinse temperature and time have been carried out as per the programme, otherwise the indicator light becomes **RED**;
- upon opening the hood, the indicator light **GOES OUT**.

If the indicator light becomes RED, for example should the boiler waiting time be disabled, wait for a couple of minutes and then repeat the wash cycle.

The temperature shown on the display is that of the tank if the light "D" is on, or of the boiler if the indicator light "F" is on. The tank temperature is displayed during the wash cycle and the boiler temperature during the rinse cycle.

Table 2 Control panel

Described below are all the single keys and functions present in the various control panel models listed above. Some functions are shared by all models of the range, whereas others are available only on several versions.

F1 Basic controls

On/Off



This key indicates the status of the equipment: on or off. When the appliance is on, the key is lit.

Wash cycle 1



This button starts wash cycle 1. This cycle is recommended for washing not very dirty dishes.



Note

Only for Singapore market, consider this wash programme for normal soiled washware.

Wash cycle 2



This button starts wash cycle 2. This cycle is recommended for washing normally dirty dishes.

Wash cycle 3



This button starts wash cycle 3. This cycle is recommended for washing very dirty dishes.

High Productivity or NSF/Ansi 3 compliant mode



This button is used to go from High Productivity wash mode to NSF/Ansi 3 compliant mode and vice versa.

Drain / self-cleaning cycle



This button starts a drain / self-cleaning cycle.

Delime cycle



This button is used to run a machine water circuit delime cycle with vinegar.

When a cycle is selected, the corresponding button is lit up.

G

STARTING

G1 Preliminary checks, adjustments and operational tests



IMPORTANT!

These operations must only be carried out by specialized technicians provided with adequate personal protection equipment (e.g. safety footwear, gloves, glasses, etc.), tools and suitable ancillary equipment.

G1.1 Electrical and plumbing checks

Before starting the machine:

- check correct connection of the electrical wires that feed the machine;
- make sure the power supply voltage and frequency match the data given in Table 1;
- check correct connection of the water supply and drain pipes (see par. E6 "Plumbing connections");
- make sure all the guards and safety devices are in place and efficient.

G1.2 Check the positioning of tank components



IMPORTANT!

The following operations must be carried out by operators provided with suitable personal protection equipment (e.g. protective gloves, etc.) with the machine switched off and cold.

G1.2.1 Check the fitting of filters and overflows

In versions with supplementary filtering system (FS), make sure the pump suction filter "1", the tank filter "2", the flat filter "3" and the basket filter "4" are correctly fitted ("A" - Figure 16).

In versions without supplementary filtering system (FS), make sure the pump suction filter "1", the overflow "2" and the flat filter "3" are correctly fitted ("B" - Figure 16).

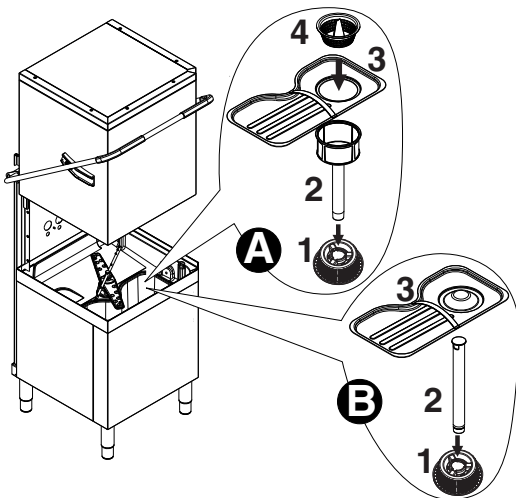

Figure 16 Filters and overflow

When the appliance is filled with water for the first time in the day, pump "S" dispenses a rinse-aid quantity in

G1.2.2 Arm fitting check

Make sure the upper and lower wash and rinse arms are correctly fitted (Figure 17).

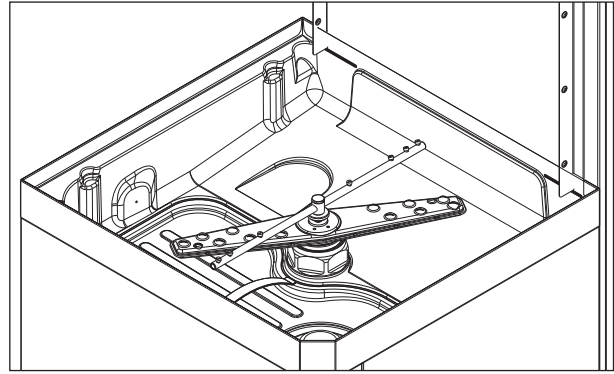

Figure 17 Wash and rinse arms

G2 Starting

- Open the water supply valves.
- Turn the main switch of the machine to "I".
- Press the On/Off key Table 2 ("A" - "Control panel").

G3 Detergent/rinse-aid dispensers and settings

If the appliance is connected to a water softener or osmotic device, contact the detergent supplier for a specific product.

If the peristaltic dispensers are installed in the machine, the detergent/ rinse aid dosage is made automatically according to the desired concentration.

The detergent / rinse aid concentration depends on the product type and the water supply hardness (check the features on the product label).

IMPORTANT

The peristaltic dispensers (detergent and rinse aid) and the tube inside the rinse aid dispenser require periodical maintenance (at least once or twice a year) or after prolonged periods of machine inactivity.

1. Dishwasher with incorporated detergent dispenser (Figure 18).

When the appliance is filled with water for the first time in the day, pump "R" dispenses a detergent quantity in the tank providing a concentration of 2 g/l. In order to change this value, access the parameter *d i n* (see G4 Setting the dispensers).

At each cycle, pump "R" dispenses a detergent quantity in the tank providing a concentration of 2 g/l. In order to change this value, access the parameter *d E t* (see G4 Setting the dispensers).

Insert the supplied hose into the detergent container.

2. Dishwashers with incorporated peristaltic rinse-aid dispenser (Figure 18).

the boiler providing a concentration of 0,1 g/l.

In order to change this value, access the parameter r_{in} (see G4 Setting the dispensers).

At each rinse cycle, pump "S" dispenses a rinse-aid quantity in the boiler providing a concentration of 0,1 g/l. In order to change this value, access the parameter r_{R} (see G4 Setting the dispensers).

Insert the supplied hose into the rinse-aid container.

Connections for automatic detergent dispenser (Figure 18)

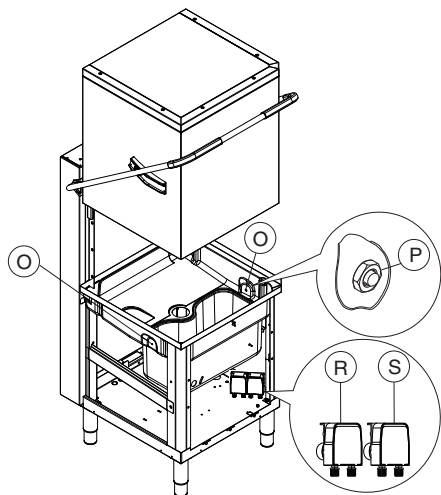

Figure 18 Automatic dispenser arrangement

There are two holes (plugged) "O" (Ø 5mm) for introducing the detergent. These holes may be easily identified from outside by looking for the countersunk marks on the external panel.

Inside the tank there is a hole "P" (Ø 10 mm) closed with a plug, which may be used for mounting a liquid detergent injector.

Electrical connections for automatic detergent and rinse-aid dispensers.

Terminals are available on the power supply terminal board for the electrical connection of external dispensers working at 220-240 V. Max. power 30 VA.

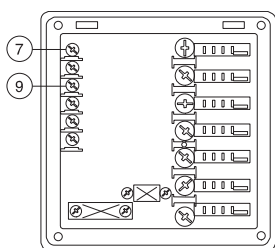

Figure 19 Detergent dispenser terminal block

- Connect the **detergent dispenser** between terminals 7 and 9. These connection points are live for a set time during filling of the tank and at the start of the wash cycle (see paragraph G4 "Setting the

dispensers").

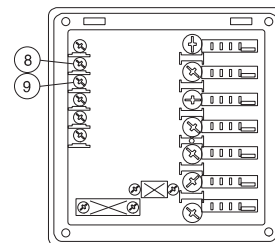
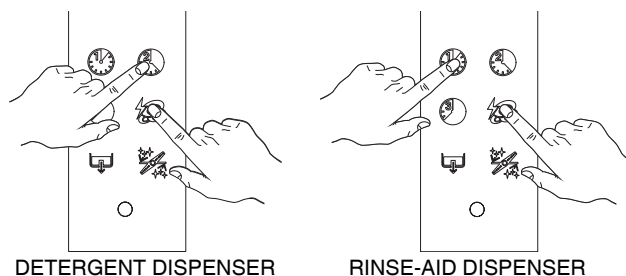

Figure 20 Rinse aid dispenser terminal block

- Connect the **rinse-aid dispenser** between terminals 8 and 9. These connection points are live during filling of the tank and at the end of the rinse cycle for a set time (see paragraph G4 "Setting the dispensers").

MANUAL ACTIVATION

Whenever the detergent containers are replaced, it may be necessary to activate the dispensers manually in order to fill the hoses and eliminate any air. Simultaneously press the buttons, as shown in the figures below. If necessary, repeat this operation several times.



G4 Setting the dispensers

All operations should be carried out with the appliance switched on, the hood open and no cycle selected.

Press the On/Off button ("A" - Table 2 "Control panel") and Wash cycle 1 button ("G" - Table 2 "Control panel") together for 5 seconds, to access the programming mode and the display shows the parameter "U5r".

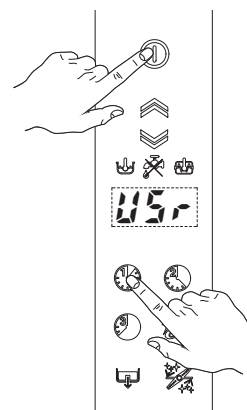

Press the button ("L" - Table 2 "Control panel") twice to access the detergent and rinse aid adjustment parameters.

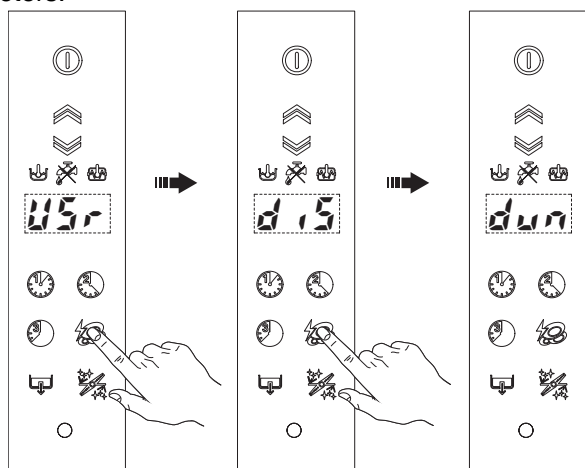

The display shows *dun* which is the first parameter of the dispenser family:

Parameter description		Value (*)
Unit of measure of dispensers (G-l = g/l or SEI = seconds)	<i>dun</i>	G-l
Initial amount of detergent	<i>d in</i>	2,00 g/l
Initial amount of rinse-aid	<i>r in</i>	0,12 g/l
Amount of detergent during the cycle	<i>dEt</i>	2,00 g/l
Amount of rinse-aid during the cycle	<i>rA,</i>	0,12 g/l

(*) The values given in the table refer to the factory-settings.

1. Use the Wash cycle 1 ("G" - Table 2 Control panel) and Wash cycle 2 ("H" - Table 2 Control panel) buttons to select the parameter to modify.
2. Press the button ("L" - Table 2 Control panel) to modify the parameter value.
3. Press the Wash cycle 1 ("G" - Table 2 Control panel) and Wash cycle 2 ("H" - Table 2 Control panel) buttons respectively to decrease/increase the value.
4. Press the button ("L" - Table 2 Control panel) to store the set value and return to parameter selection (see point 1).

For example, to adjust the parameter *d in*, proceed as follows:

- access the programming mode

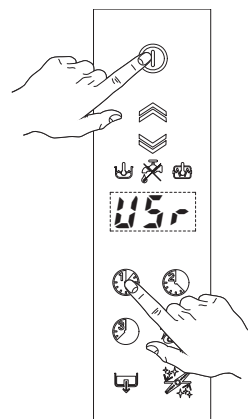

- access the dispenser family

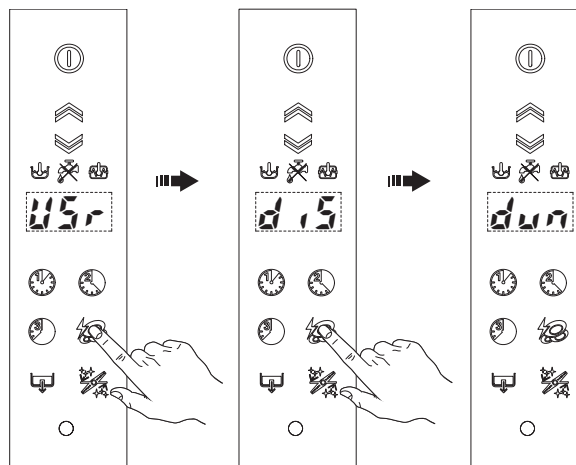

- Select the parameter *d in*

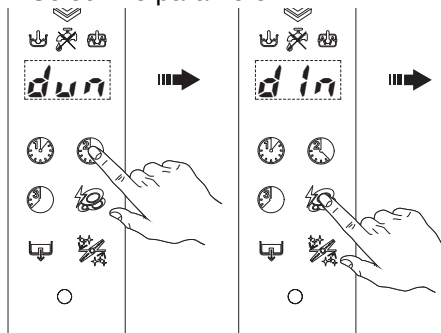

- modify the parameter value

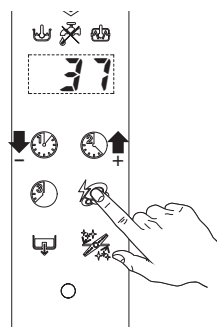

Press the button ("L" - Table 2 Control panel) to store the set value.

To exit the programming mode, press the Wash cycle 3 button ("I" - Table 2 "Control panel").



External dispenser adjustment

With external dispensers, it may be more useful to have the parameters expressed in seconds, setting the parameter dun to $5\text{E}1$ =seconds. In this way the value of the parameters represents the duration in seconds.

Listed below are special values usable when external automatic dispensers are connected to the equipment:

- if $dEt = 181$ the **detergent dispenser** only operates during **wash pump** operation; terminals **7-9** of the main terminal board are powered at the same time.
- if $dEt = 182$ the **detergent dispenser** only operates during **filling electrovalve** operation for restoring the boiler level; terminals **7-9** of the main terminal board are powered at the same time.
- if $rA = 61$ the **rinse-aid dispenser** only operates during **filling electrovalve** operation for restoring the boiler level; terminals **8-9** of the main terminal board are powered at the same time.
- if $rA = 62$ the **rinse-aid dispenser** only operates during **wash pump** operation; terminals **8-9** of the main terminal board are powered at the same time.

For connections, see the wiring diagram.

Example 1:

Supposing that an external detergent dispenser has been connected with a tank concentration measuring sensor, a standard setting could be as follows:

- $dun = 5\text{E}1$ the parameter value is in seconds.
- $dIn = 0$ the dispenser is not activated during filling of the tank.
- $dEt = 181$ the dispenser is activated during wash pump operation and, according to the concentration of detergent detected by the sensor, the correct amount of detergent is dispensed.

Example 2:

Supposing that an external rinse-aid dispenser has been connected with a tank concentration measuring sensor, a standard setting could be as follows:

- $dun = 5\text{E}1$ the parameter value is in seconds.
- $rA = 61$ the dispenser is activated at each wash cycle simultaneously with operation of the filling solenoid valve. In this way avoiding modifications to the wiring of the machine.

Suggestion: to check the effectiveness of the rinse-aid, look at freshly washed glasses against the light. Drops of water remaining on the glass indicate an insufficient amount while streaks indicate an excess.

Changing the detergent/rinse-aid type.

If changing to a **different detergent/rinse-aid type** (even one by the same manufacturer), you must rinse the suction and pressure hoses with fresh water before connecting the new detergent/rinse-aid container.

IMPORTANT

The mixing of different types of detergent/rinse-aid will cause crystallisation, which may result in a breakdown of the dosing pump. Failure to observe this condition will invalidate the guarantee and product liability.

H GENERAL SAFETY RULES

H1 Introduction

The machines are provided with electric and/or mechanical safety devices for protecting workers and the machine itself. Therefore the user must not remove or tamper with such devices.

The Manufacturer declines any liability for damage due to tampering or their non-use.

H1.1 Protection devices installed on the machine

H1.1.1 Guards

The guards on the machine are:

- fixed guards (e.g. casings, covers, side panelling, etc.), fixed to the machine and/or frame with screws or quick-release couplings that can only be removed or opened with tools;
- interlocked movable guards (front panels) for access to inside the machine;
- access doors to the machine's electrical equipment, made from hinged panels openable with tools. The door must not be opened during machine movement, if inside the door there is equipment that is hazardous when live or under pressure.



IMPORTANT!

Several illustrations in the manual represent the machine, or parts of it, without guards or with guards removed. This is purely for explanatory requirements. Never operate the machine without the guards or with the safety devices deactivated.

H1.2 Safety signs to be displayed on the machine or near the work area

		MEANING
P R O H I B I T I O N		Do not oil, lubricate, repair and adjust moving parts.
		Do not remove the safety devices.
		Do not use water to extinguish fires (shown on electrical parts).
D A N G E R		DANGER OF CRUSHING HANDS
		DANGER OF BURNS
		DANGER OF ELECTROCUTION (shown on electrical parts with indication of voltage).



WARNING!

Do not remove, tamper with or make the labels on the machine illegible.

H2 Decommissioning

When the machine is no longer to be used, make it unusable by removing the feed wiring from the power supply and the water connections.

H3 Instructions for use and maintenance

Risks mainly of a mechanical, thermal and electrical nature are present in the machine.

Where possible the risks have been neutralized:

- directly, by means of adequate design solutions,
- or indirectly by using guards, protection and safety devices.

Any anomalous situations are signalled on the control panel display.

During maintenance several risks remain, as these could not be eliminated and which must be neutralized through specific behaviour and precautions.

Do not carry out any control, cleaning, repair or maintenance operations on moving parts.

Workers must be informed of the prohibition by means of clearly visible signs.

To guarantee machine efficiency and correct operation, periodical maintenance must be carried out according to the instructions given in this manual.

In particular, make sure to periodically check correct operation of all the safety devices and the insulation of electrical cables, which must be replaced if damaged.



IMPORTANT!

Machine maintenance operations must only be carried out by specialized Technicians provided with all necessary personal protection equipment (safety shoes, gloves, glasses, overalls, etc.), tools, utensils and suitable ancillary means.



WARNING!

Never operate the machine by removing, modifying or tampering with the guards and protection or safety devices.



IMPORTANT!

Before carrying out any operation on the machine, always consult the manual which gives the correct procedures and contains important information on safety.

H4 Improper use

Improper use is any use differing from that specified in this manual. During machine operation, other types of work or activities considered improper and that in general can involve risks for the safety of operators and damage to the system are not allowed.

Improper use includes:

- failure to disconnect the power supply with the main switch in “O” off position before carrying out adjustment, cleaning, resetting and maintenance operations;
- failure to disconnect the power supply with the main switch in off position “O” at the end of the day;
- lack of machine maintenance, cleaning and periodical checks;
- structural changes or modifications to the operating logic;
- tampering with the guards or safety devices;
- failure to use personal protection equipment by operators, specialized technicians and maintenance personnel;
- failure to use suitable accessories (e.g. use of equipment, ladders, etc., unsuitable for carrying out maintenance on equipment positioned inside the machine);
- keeping combustible or flammable materials, or in any case materials not compatible with or pertinent to the work, near the machine;
- incorrect machine installation (see chapter E “Installation and assembly”);
- placing in the machine any objects or things not compatible with washing or that can obstruct/damage the machine or persons or pollute the environment;
- non-compliance with the requirements for correct machine use;
- other actions that can cause risks not eliminable by the Manufacturer.

H5 Residual risks

The machine has several risks that were not completely eliminated from a design standpoint or with the installation of adequate protection devices.

Nevertheless, through this manual the Manufacturer has taken steps to inform operators of such risks, carefully indicating the personal protection equipment to be used by them.

Sufficient spaces are provided for during the machine installation phases in order to limit these risks.

To preserve these conditions, the corridors and areas around the machine must always be:

- kept free of obstacles (e.g. ladders, tools, containers, boxes, etc.);
- clean and dry;
- well lit.

For the Customer’s complete information, the residual risks remaining on the machine are given below; such actions are to be considered incorrect and therefore strictly forbidden.

APPLICATION PHASE: I=Installation, U=Normal use, M=Maintenance, P=Cleaning.

RESIDUAL RISK	DESCRIPTION OF HAZARDOUS SITUATION
Slipping or falling [U - M]	The operator can slip due to water or dirt on the floor.
Burns [U - M - P]	The operator deliberately or unintentionally touches some components inside the machine or dishes at the outfeed without using gloves or without allowing them to cool.
Electrocution [M]	Contact with live parts during maintenance operations carried out with the electrical panel powered. The operator intervenes (with a power tool or without disconnecting the power to the machine) lying down on the wet floor.
Falling from above [I - U - M]	The operator intervenes on the machine using unsuitable systems to access the upper part (e.g. rung ladders, or climbs on it).
Tipping of loads [I - M]	During maintenance on the machine or the packing containing the machine with the use of unsuitable accessories or lifting systems or with load unbalanced.
Chemical [I - U - M - P]	Contact with chemical substances (e.g. detergent, rinse aid, scale remover, etc.) without taking adequate safety precautions. Therefore always refer to the safety cards and labels on the products used.
Crushing or shearing [I - U - M]	Possible risk of injury to upper limbs during the hood closing operation.

Table 3 Residual risks

I NORMAL MACHINE USE

I1 Correct use

Our appliances are designed and optimized in order to obtain high performance and efficiency. This equipment must only be used for its expressly designed purpose, i.e. washing dishes with water and specific detergents. Any other use is to be deemed improper.

I2 Characteristics of personnel enabled to operate on the machine

Operator qualified for normal use must have at least:

- knowledge of the technology and specific experience in operating the machine;
- adequate general basic education and technical knowledge for reading and understanding the contents of the manual,
- the capacity for a correct interpretation of the drawings, signs and pictograms;
- sufficient technical knowledge for safely performing his duties as specified in the manual;
- knowledge of the regulations on work hygiene and safety.

In the event of a significant anomaly (e.g. short circuits, wires coming out of the terminal block, motor breakdowns, worn electrical cable sheathing, etc.) the operator qualified for normal machine use must:

- immediately deactivate the machine by turning the main switch to "O" ;
- close the machine water supply by shutting off the water.

I3 First use

Carry out a couple of cycles without dishes to flush out any industrial grease which has remained in the tank and piping.

I4 Daily activation of machine

- Make sure the filters, arms and the overflow are correctly fitted according to that indicated in par. G1.2 "Check the positioning of tank components" and E8 "Energy control arrangement".
- Open the water supply valves.
- Activate the main switch by turning it to position "I".
- Switch on the dishwasher by pressing the button "A".



- Raise the hood (with an automatic appliance, by pressing the open/close button "B/C" - Table 2 "Control panel") and check that all the components are in their correct position.
- Close the hood (with an automatic appliance, by pressing the open/close button "B/C" - Table 2 "Control panel").

The button "A" lights up (Table 2 "Control panel"), indicating that the dishwasher is powered and that water is being introduced and heated.

The word "FILL" is shown on the display during the entire filling and heating stage:



Warning, this dishwasher does the first tank filling through several consecutive hot rinse cycles, while the display shows the message FILL (flowing).

This system let save up to 30% of time than traditional models.

If the hood is opened during this stage the message "CLOSE" will appear on the display:



The filling and heating stage has finished when the display shows the tank temperature:



To display the boiler temperature during heating of the tank, leave the hood and press the button "G" (Table 2 "Control panel").



IMPORTANT

If the indicator "E" (see Table 2 "Control panel") lights up, check that the water valve is open (see par. I7 Allarms).

I5 Wash cycles

The wash cycle includes a wash with hot water and detergent at a temperature of at least 55°C and a rinse with hot water and rinse aid (min. 82°C).

This machine can operate in 2 modes, "High Productivity" and "NSF/Ansi 3 compliant". When the machine is set in "High Productivity" mode, the parameters that define the cycle times and temperature set points are the standard parameters, whereas when the machine is set in "NSF/Ansi 3 compliant" mode, the parameters are such as to ensure the "NSF/Ansi 3 compliant" test (see times table).

Table of times

Standard cycle time with supply water in "high productivity" mode:

I	II	III
45 (***)	84	150

Standard cycle time with supply water in NSF/Ansi 3 compliant mode (factory default setting):

I	II	III
57 (***)	84	150

(***) With supply water temperature at 65°C.

A device lengthens the cycle time if the water in the boiler has not reached the minimum temperature for correct rinsing.

The cycle times and the temperature may be personalised (e.g. increase of the rinse time and temperature). The cycle times should only be set by a specialised technician.

I6 Operation

The filling and heating stage has finished when the display shows the tank temperature:



The appliance is then ready for use:

- Leave the hood.
- Pour the required amount of detergent non-foaming into the tank (in models without automatic dispenser).
- Arrange dishes in the rack, avoiding washing decorated dishes, silverware in contact with other metals and the drying of food residuals on dishes.

IMPORTANT

Remove large food scraps from the dishes to prevent clogging the filters.

- Pre-wash the dishes by spraying them with cold or lukewarm water, without using any detergent.
- Insert the rack containing the dirty dishes.
- Close the hood and select the suitable wash cycle; the corresponding indicator light comes on and the wash cycle starts.

Usable wash cycles:

- Cycle I

For lightly soiled dishes: press button "G" (see Table 2 "Control panel" and table of times).



- Cycle II (recommended)

For normally dirty dishes: press button "H" (see Table 2 "Control panel" and table of times).



- Cycle III

For very dirty dishes: press button "I" (see Table 2 "Control panel" and table of times).



- High Productivity or NSF/Ansi 3 compliant mode

Press and hold down (5 sec.) the button "L" (see Table 2 "Control panel") to switch the machine from "High Productivity" mode to "NSF/Ansi 3 compliant" mode and vice versa. The button "L" is off when the machine is set in "NSF/Ansi 3 compliant" mode (factory default setting) and lights up when the button is pressed and the machine is configured in "High Productivity" mode.



- To stop the wash cycle, just press the selected cycle button or leave the hood.
- To continue the wash cycle, just press the selected cycle button or close the hood. The cycle starts again from where it stopped.
- At the end of the wash, the dishwasher emits a series of beeps and "END" blinks on the display:



lift the hood and remove the rack containing the clean dishes.

- Delime cycle (if enabled)

Press the button "N" (see Table 2 Control panel)



to run a machine water circuit delime cycle with vinegar.

It is advisable to run this cycle according to that given in the table:

Water hardness			The Delime cycle should be run approximately every (*):	Using cycle 2 for 30 cycles/day, the Delime cycle should be run approximately every (*):
°f	°d	°e	Cycles	Days
5	2,8	3,5	1500	50
10	5,6	7,0	750	25
15	8,4	10,5	510	17
20	11,2	14	380	13
25	14	17,5	300	10
30	16,8	21,1	250	8

(*). Considering a rinse time according to the factory settings.

Proceed as follows:

- Insert the Delime tube present in the machine, identified by an appropriate label, in a container with at least 2l of wine vinegar 6% (2l is the minimum amount of vinegar needed for a correct Delime cycle).

IMPORTANT

Only use wine vinegar and not other descaling substances. Descaling with the use of chemical substances other than vinegar must only be done by a specialized technician.

- Remove the basket with dishes and remove the overflow "2" (see Figure 16 Filters and overflow).
- Close the hood.
- Activate the delime cycle by pressing the button "N" (see Table 2 Control panel) for at least 5 seconds.

IMPORTANT

The delime cycle lasts about 1h 30sec; during this phase the hood must not be opened and no other command can be activated until completion of the cycle in progress. If the machine is turned off during the delime cycle, at the next restart the cycle will resume exactly from where it was interrupted, until its completion.

- At the end of Delime cycle, the dishwasher sounds a series of beeps and "END" will flash on the display.
- Refit the previously removed overflow.

IMPORTANT

The appliance will not remove burnt food deposits from dishes. Dishes with burnt-on food deposits should be cleaned mechanically/chemically (for example, pre-wash under running water) before putting them in the dishwasher.

IMPORTANT

The use of "foaming"/non-specific detergents or in any case detergents used in different ways from that prescribed by the manufacturer, can cause damage to the dishwasher and compromise washing results.

IMPORTANT

Failure to remove the residuals of detergent possibly used for manual prewash can cause malfunctioning of the dishwasher and compromise washing results.

Change the water in the tank at least once a day.

Type of racks and loading

- YELLOW rack: for 18 plates with maximum diameter of 240 mm.

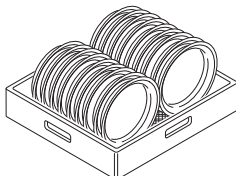

Figure 21 YELLOW rack

- GREEN rack: for 12 bowls with maximum diameter of 240 mm.

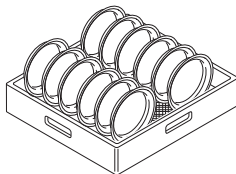

Figure 22 GREEN rack

- BLUE rack for glasses: the glasses should be placed upside down.

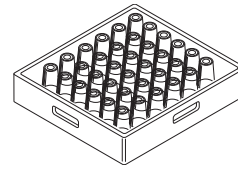

Figure 23 BLUE rack for glasses

- YELLOW container for cutlery: insert 15 items, with the handles pointing downwards, in each container.



Figure 24 YELLOW container for cutlery

Available as accessories: dividers for glasses and rack for dishes with maximum diameter of 320 mm.

Note: if only one type of dish rack is to be used, it is advisable to choose the GREEN rack.

17 Alarms

In case of a generic dishwasher fault, the display shows the relevant alarm code.

For example:

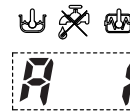

List of possible documented machine alarms with respective cause / cure.

Code	Description	Cause / Solution
A1 (*)	NO WATER	Check that the valve is open. Check that the water inlet filter is clean. Check the minimum mains pressure. Check that the overflow pipe is inserted.
B1	INEFFICIENT DRAINAGE	Check if the overflow has been removed. Check for obstruction on the waste outlet pipe and the overflow aperture.
B2	TANK WATER LEVEL TOO HIGH	Check for obstruction on the waste outlet pipe and the overflow aperture.
C1..C9	CALL THE SERVICE CENTRE	
E1..E8	CALL THE SERVICE CENTRE	The appliance continues to operate, but appropriate checks by a technician are recommended.
F21..F22	CALL THE SERVICE CENTRE	

(*) When the display shows alarm A1, the "water tap" indicator also lights up ("E" - Table 2 "Control panel").

18 Machine cleaning

Cleaning must be carried out after every day of use. Use hot water, a neutral detergent/deterasive if necessary, and a soft brush or sponge. If another type of detergent is used carefully follow the manufacturer's instructions and observe the safety rules given in the information cards provided with the product or substance.

In order to reduce the environmental impact of pollutant substances, clean the equipment (externally and internally where necessary) with products that are more than 90% biodegradable.



CAUTION!

Do not use steel wool or similar material to clean s/steel surfaces. Do not use detergents containing chlorine.



IMPORTANT!

Do not clean the machine with jets of water.



CAUTION!

Contact with chemical substances (e.g. detergent, rinse aid, scale remover, etc.) without taking appropriate safety precautions (e.g. personal protection equipment) can involve exposure to chemical risk and possible damage to health. Therefore always refer to the safety cards and labels on the products used.

18.1 End of service and daily internal cleaning

The appliance is designed to carry out an automatic cleaning cycle to help flush out any residues and to guarantee greater health and hygiene:

- Lift the hood and take out the rack containing the clean dishes.
- In versions with supplementary filtering system (FS), remove the basket filter "1", the flat filter "2", the tank filter "3" and the pump suction filter "4" ("A" - Figure 25).
- In versions without supplementary filtering system (FS), remove the flat filter "1", the overflow "2" and the pump suction filter "3" ("B" - Figure 25).

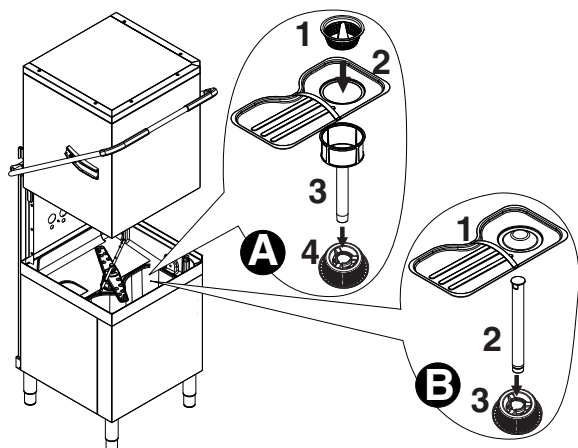

Figure 25 Filters and overflow

- Close the hood.
- Select the drain cycle by pressing button "M" (Table 2 "Control panel").



The message "CLE" ("CLEAN") will be displayed throughout the drain cycle:



- After a few minutes, 3 beeps indicate the end of the cleaning cycle and "END" blinks on the display:



- Switch off the dishwasher by pressing button "A" (Table 2 "Control panel").



- Switch off at the mains.
- Close the water supply valve.
- Replace the filter and the overflow.

Cleaning the nozzle jets

- Remove the upper and lower wash arms "F" and rinse arms "I", undoing the ring nut "H" (Figure 26).

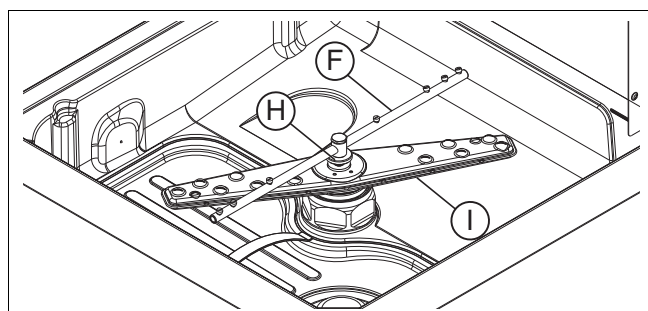

Figure 26 Wash and rinse arms

- Carefully clean the washing and rinse jets and clean everything with hot water and neutral detergent/deterasive, if necessary using a soft brush or sponge. Do not use sharp implements to clean the nozzle holes, which could otherwise be damaged.

Upon completion of cleaning operations, replace the parts removed previously.

18.2 Exterior cleaning

Before carrying out any cleaning operations, turn off the power at the mains.

IMPORTANT

Clean the stainless steel surfaces using warm soapy water; never use detergents containing abrasive substances nor steel scrapers, common wire wool, brushes or scrapers; rinse thoroughly using a wet cloth and carefully wipe dry.

Clean the control panel using a soft damp cloth and a neutral detergent if necessary.

Do not wash the appliance using direct or high-pressure water jets.

To reduce the emission of pollutants into the environment, clean the appliance (externally and where necessary internally) with products having a biodegradability of over 90%.

Leave the hood raised whenever the appliance is not in use.

I9 Long idle periods

Whenever the dishwasher is not going to be used for a long period of time (e.g. one month), carefully carry out the following instructions.

- Close the water supply valve.
- Completely drain the tank.
- Remove and carefully clean the filters.
- Completely drain the incorporated dispenser hoses, removing them from the containers. Repeat the procedure described in the paragraph "Manual activation" at least 3 times.
- Completely drain the boiler.
- Clean the inside and outside of the machine as indicated in par. I8.1 "End of service and daily internal cleaning" and I8.2 "Exterior cleaning".
- Spread a film of paraffin oil over the steel surfaces.

When using the machine again, follow the indications in par. I4 "Daily activation of machine".

I10 Maintenance

Inspection and maintenance intervals depend on the actual machine operating conditions (total wash hours) and ambient conditions (presence of dust, damp, etc.), therefore precise time intervals cannot be given. In any case, to minimize interruptions of the service, careful and periodical machine maintenance is advisable.

Therefore, it is advisable to:

- Descale the boiler, inside surfaces of the tank and the machine piping once or twice a year (call technical assistance).
- Every month descale the wash and rinse jets with vinegar or scale remover.
- The internal hose of the rinse-aid and detergent peristaltic dispenser should undergo periodic maintenance (once or twice a year).
- If present, clean the finned coil of the energy saving device once or twice a year (call technical assistance).

It is also advisable to stipulate a scheduled preventive maintenance contract with technical assistance.

I10.1 Preventive maintenance

The preventive maintenance call can be activated (call technical assistance).

On reaching the set number of cycles (e.g. 20000), a technical assistance call message appears on the display.

This message suggests calling a specialized technician, for a general check of the equipment.

I11 Machine disposal

At the end of the product's life cycle, make sure the equipment is not dispersed in the environment. The equipment must be disposed of in compliance with current regulations in the country of use.

All metal parts are in s/steel (AISI 304) and removable. Plastic parts are marked with the letters of the material.

The symbol  on the product indicates that this product should **not** be treated as domestic waste, but must be correctly disposed of in order to prevent possible negative consequences for the environment and the human health.

Regarding the recycling of this product, please contact the sales agent or dealer of your product, your after-sales service or the appropriate waste disposal service.

I12 Troubleshooting

DISHWASHER DOES NOT WASH WELL
<ol style="list-style-type: none">1. Check if the suction filter is dirty and clean it thoroughly.2. Check if the wash jets are clogged by solid food remains.3. Check that the initial amount of detergent or subsequent additions are correct.4. The selected wash cycle is too short. Repeat the cycle.5. Check that the tank temperature is at least 55°C.6. Check that the dishes are stacked correctly in the racks.
GLASSES AND DISHES ARE NOT DRIED PROPERLY
<ol style="list-style-type: none">1. Check that there is rinse-aid in the container and if necessary top up.2. Check the set amount of rinse-aid (see "setting the dispensers" paragraph).3. Check that the water temperature is between 80°C and 90°C.
CONDENSATION ON GLASSES
<ol style="list-style-type: none">1. Check that there is rinse-aid in the container and if necessary top up.2. Check the set amount of rinse-aid (see "setting the dispensers" paragraph).3. Remove the rack of glasses immediately the cycle has ended.
STAINS ON THE GLASSES
<ol style="list-style-type: none">1. Only use "non-foaming" products for professional dishwashers.
EXCESSIVE FOAM IN THE TANK
<ol style="list-style-type: none">1. Check that the wash water temperature is not less than 55°C.2. Check if the amount of product dispensed by the detergent dispenser is excessive (see "setting the dispensers" paragraph).3. Ensure that the tank has not been cleaned with unsuitable cleaners. Drain the tank and rinse thoroughly before new wash cycles.4. If a foaming detergent has been used, drain and refill the tank with water until the foam disappears.
SMEARS OR SPOTS ON THE GLASSES
<ol style="list-style-type: none">1. Reduce the amount of rinse-aid (see "setting the dispensers" paragraph).
THE WASH OR RINSE ARMS TURN SLOWLY
<ol style="list-style-type: none">1. Remove and thoroughly clean the arms.2. Clean the wash pump suction filter.