

A	SAFETY INSTRUCTIONS	Page	6
B	GENERAL INFORMATION	Page	7
B1	Introduction	Page	7
B2	Definitions	Page	7
B3	Typographical conventions	Page	7
B4	appliance and Manufacturer's identification data	Page	8
B5	appliance identification	Page	8
	B5.1 How to identify the technical data	Page	8
	B5.2 How to interpret the factory description	Page	8
B6	Copyright	Page	8
B7	Liability	Page	8
B8	Personal protection equipment for use and maintenance	Page	9
B9	Keeping the manual	Page	9
B10	Users of the manual	Page	9
C	GENERAL DESCRIPTION OF THE APPLIANCE	Page	10
C1	General description	Page	10
D	TECHNICAL DATA	Page	10
D1	Main technical characteristics	Page	10
D2	Characteristics of power supply	Page	11
E	TRANSPORT, HANDLING AND STORAGE	Page	12
E1	Introduction	Page	12
	E1.1 Transport: Instructions for the carrier	Page	12
E2	Handling	Page	12
	E2.1 Procedures for handling operations	Page	12
	E2.2 Translation	Page	12
	E2.3 Placing the load	Page	12
E3	Storage	Page	12
F	INSTALLATION AND ASSEMBLY	Page	13
F1	Customer responsibilities	Page	13
F2	Characteristics of the place of appliance installation	Page	13
F3	Appliance space limits	Page	13
F4	Positioning	Page	13
F5	Disposal of packing	Page	14
F6	Plumbing connections	Page	14
	F6.1 Plumbing circuits	Page	15
	F6.2 Installation diagrams	Page	16
F7	Electrical connections	Page	18
F8	Energy control arrangement	Page	19
G	DESCRIPTION OF CONTROL PANEL	Page	20
G1	Basic controls	Page	20

H	STARTING	Page	21
H1	Preliminary checks, adjustments and operational tests	Page	21
	H1.1 Electrical and plumbing checks	Page	21
	H1.2 Check the positioning of tank components	Page	21
	H1.2.1 Check the fitting of filters	Page	21
	H1.2.2 Arm fitting check	Page	21
H2	Starting	Page	21
H3	Detergent/rinse-aid dispensers and settings	Page	21
H4	Setting the dispensers	Page	22
I	GENERAL SAFETY RULES	Page	24
I1	Introduction	Page	24
	I1.1 Protection devices installed on the appliance	Page	24
	I1.1.1 Guards	Page	24
	I1.2 Safety signs to be displayed on the appliance or near the work area	Page	24
I2	Decommissioning	Page	24
I3	Instructions for use and maintenance	Page	24
I4	Improper use	Page	25
I5	Residual risks	Page	25
J	NORMAL appliance USE	Page	26
J1	Correct use	Page	26
J2	Characteristics of personnel enabled to operate on the appliance	Page	26
J3	First use	Page	26
J4	Daily activation of appliance	Page	26
J5	Wash cycles	Page	26
J6	Operation	Page	26
J7	Alarms	Page	27
J8	Appliance cleaning	Page	28
	J8.1 End of service and daily internal cleaning	Page	28
	J8.2 Exterior cleaning	Page	29
J9	Long idle periods	Page	30
J10	Maintenance	Page	30
	J10.1 Preventive maintenance	Page	30
J11	Appliance disposal	Page	30
J12	Troubleshooting	Page	30

INDEX OF FIGURES

Figure 1	Reproduction of the marking/dataplate on the appliance.....	Page	8
Figure 2	Position of marking.....	Page	8
Figure 3	Technical data identification.....	Page	8
Figure 4	Example of document identification data.	Page	9
Figure 5	Unpacking	Page	13
Figure 6	Appliance positioning	Page	13
Figure 7	Removal of wooden spacers.....	Page	13
Figure 8	Removing the film	Page	14
Figure 9	Feet adjustment	Page	14
Figure 10	Feed pipe connection.....	Page	14
Figure 11	380-415 V 3N.....	Page	19
Figure 12	400-440V 3	Page	19
Figure 13	220-230V 3	Page	19
Figure 14	Energy control.....	Page	19
Figure 15	Tank filters.....	Page	21
Figure 16	Wash and rinse arms	Page	21
Figure 17	Automatic dispenser arrangement	Page	22
Figure 18	Detergent dispenser terminal block.....	Page	22
Figure 20	Wash water pressure adjustment.....	Page	27
Figure 21	Basket for items	Page	27
Figure 22	Tray rack	Page	27
Figure 23	Release the door.....	Page	28
Figure 24	Tank filters.....	Page	28
Figure 25	Refit the door	Page	28
Figure 26	Rotating wash arms and rinse arms.....	Page	29
Figure 27	Fixed wash arm removal	Page	29
Figure 28	Fixed wash arm cleaning	Page	29

INDEX OF TABLES

Table 1	Main technical characteristics, performance and consumption.....	Page	10
Table 2	Control panel.....	Page	20
Table 3	Residual risks.....	Page	25

Foreword

The instruction manual (hereinafter Manual) provides the operator with useful information for working correctly and safely, facilitating him in using the appliance.

The following must not be considered a long and exacting list of warnings, but rather a set of instructions suitable for improving appliance performance in every respect and, above all, preventing injury to persons and animals and damage to property due to improper operating procedures.

All persons involved in appliance transport, installation, starting, use and maintenance, repair and dismantling must consult and carefully read this manual before performing the various operations, for the purpose of avoiding wrong and improper actions that could negatively affect the appliance's integrity or endanger persons.

The manual must always be available to operators and carefully kept in the place where the appliance is used so that it is immediately at hand for consultation in case of doubts or whenever required.

If, after reading this manual, there are still doubts regarding appliance use, do not hesitate to contact the Manufacturer, or the authorized assistance centre, to receive prompt and precise assistance for better operation and maximum efficiency of the appliance.

During all phases of appliance use, always respect the current regulations on safety, work hygiene and environmental protection. It is the user's responsibility to make sure the appliance is started and operated only in optimal safety conditions for persons, animals and property.

A SAFETY INSTRUCTIONS

- This appliance can be used by children aged from 8 years and above and persons with reduced physical, sensory or mental capabilities or lack of experience and knowledge if they have been given supervision or instruction concerning use of the appliance in a safe way and understand the hazards involved.
- Do not let children play with the appliance.

WARNING

Do not wash the appliance with direct or high pressure jets of water.

B GENERAL INFORMATION

B1 Introduction

This chapter describes the symbols used (that mark and identify the type of warning) and gives the definitions of terms used in the manual, responsibilities and copyright.

B2 Definitions

Listed below are the definitions of the main terms used in the Manual. Carefully read them before using the Manual.

Operator

an operator who carries out appliance installation, adjustment, use, maintenance, cleaning, repair and transport.

Manufacturer

Electrolux Professional S.p.A. or any other assistance centre authorized by Electrolux Professional S.p.A..

Operator qualified for normal appliance use

an operator who has been informed, instructed and trained regarding the tasks and hazards involved in normal appliance use.

Specialized technician or Technical assistance

an operator instructed/trained by the Manufacturer and who, based on his professional and specific training, experience and knowledge of the accident-prevention regulations, is able to appraise the operations to be carried out on the appliance and recognize and prevent possible risks. His professionalism covers the mechanical, electrotechnical and electronics fields.

Danger

source of possible injury or harm to health.

Hazardous situation

any situation where an operator is exposed to one or more hazards.

Risk

a combination of probabilities and risks of injury or harm to health in a hazardous situation.

Guards

safety measures consisting of the use of specific technical means (guards and safety devices) for protecting operators against dangers.

Guard

an element of a appliance used specifically to provide protection by means of a physical barrier.

Safety device

a device (other than a guard) that eliminates or reduces the risk; it can be used alone or in combination with a guard.

Customer

the person who purchased the appliance and/or who manages and uses it (e.g. company, entrepreneur, firm).

Emergency stop device

a group of components intended for the emergency stop function; the device is activated with a single action and prevents or reduces damage to persons/appliances/property/animals.

Electrocution

an accidental discharge of electric current on a human body.

B3 Typographical conventions

For best use of the manual, and therefore the appliance, it is advisable to have good knowledge of the terms and typographical conventions used in the documentation.

The following symbols are used in the manual to mark and identify the various types of hazards:



WARNING!

DANGER FOR THE HEALTH AND SAFETY OF OPERATORS.



WARNING!

DANGER OF ELECTROCUTION - DANGEROUS VOLTAGE.

appliance guards and protection devices marked with this symbol must only be opened by qualified personnel, after disconnecting the power to the appliance.



WARNING!

DANGER OF DAMAGE TO THE APPLIANCE.

Words and safety warnings further explaining the type of hazard are placed next to the symbols in the text. The warnings are intended to guarantee the safety of personnel and prevent damage to the appliance or the product being worked.

The drawings and diagrams given in the manual are not in scale. They supplement the written information with an outline, but are not intended to be a detailed representation of the appliance supplied.

The numerical values given in the appliance installation diagrams refer to measurements expressed in mm (see paragraph F6.2 "Installation diagrams").

B4 appliance and Manufacturer's identification data

A reproduction of the marking or dataplate on the appliance is given below.

ELX		Made in EU		2015
F.Mod.	EPPWESGFB	Comm. Model	EPPWESGFB	
PNC	9CGX 506062 00	Ser.Nr.	51510010	
EL	AC 400V 3N	50 Hz	Max.	20 kW
			Nominal.	13 kW
CE		IPX5		
Electrolux Professional spa - Viale Treviso, 15 - 33170 Pordenone (Italy)				

Figure 1 Reproduction of the marking/dataplate on the appliance.

The dataplate gives the product identification and technical data; the meaning of the information given on it is listed below.

F.Mod. factory description of the product
 Comm. Model trade description
 PNC: production code number
 Ser. Nr. serial number
 AC 400V 3N power supply voltage
 50 Hz power supply frequency
 20 kW max. power absorbed
 13 kW power absorbed as factory setting
 2015 year of construction
 CE CE marking
 IPX5 protection rating
 Electrolux Professional S.p.A.
 Viale Treviso, 15
 33170 Pordenone
 (Italy) Manufacturer

The marking plate is located on the right side panel of the equipment.

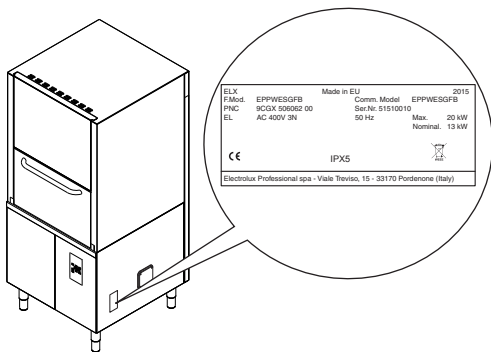

Figure 2 Position of marking



WARNING!

Do not remove, tamper with or make the appliance marking illegible.



IMPORTANT!

Refer to the data given on the appliance marking for relations with the Manufacturer (e.g. when ordering spare parts, etc.).



IMPORTANT!

When disposing of the appliance the marking must be destroyed.

B5 appliance identification

B5.1 How to identify the technical data

To identify the technical data (Figure 3) read the factory description of the product (F.Mod.) on the dataplate, identify the main appliance data and consult the Table 1 "Main technical characteristics, performance and consumption".

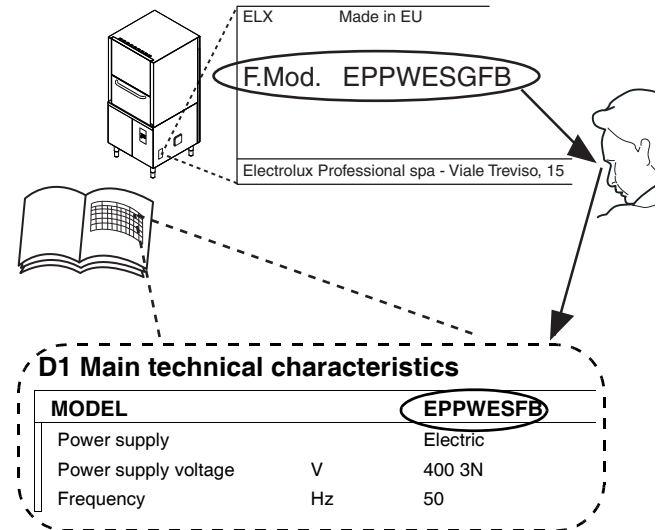

Figure 3 Technical data identification

B5.2 How to interpret the factory description

The factory description on the dataplate has the following meaning (some examples are given below):

Electric versions					
(1)	(2)	(3)	(4)	(5)	(6)
E	PPW	E	S	G	FB
E	PPW	E	H	G	FB
E	PPW	E	L	G	FB

	Variables description
(1) Mark	E = Electrolux.
(2) appliance type	PPW = Industrial cleaning appliance
(3) Supply	E = Electric
(4) Model	S = Small, H = High, L = Large
(5) (6)	G = Drain pump, FB = Fire Brigade.

B6 Copyright

This manual is intended for consultation only by the operator and can be given to third parties only with the written permission of Electrolux Professional S.p.A.

B7 Liability

The instructions are updated to the month and year given in the box located at the bottom right of the cover. The edition corresponds to the manual revision number. Every new edition replaces and cancels the previous ones.

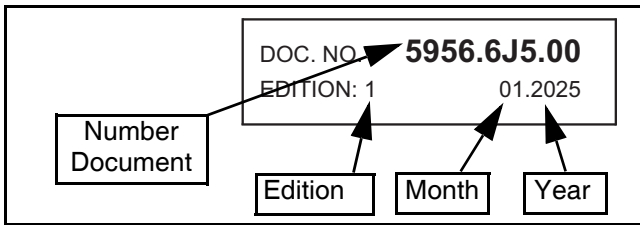

Figure 4 Example of document identification data.

The Manufacturer declines any liability for damage and malfunctioning caused by:

- non-compliance with the instructions contained in this manual;
- repairs not carried out in a workmanlike fashion, and replacements using spare parts different from those specified in this manual (the fitting and use of non-original spare parts and accessories can negatively affect appliance operation);
- operations by non-specialized technicians;
- unauthorized modifications or operations;
- inadequate maintenance;
- improper appliance use;
- unexpected extraordinary events;
- use of the appliance by uninformed and untrained personnel;
- non-application of the current provisions in the country of use, concerning safety, hygiene and health in the workplace.

The Manufacturer declines any liability for damage caused by arbitrary modifications and conversions carried out by the user or the Customer.





The employer or workplace manager is responsible for identifying and choosing adequate and suitable personal protection equipment to be worn by operators, in compliance with current regulations in the country of use.

Electrolux Professional S.p.A. declines any liability for possible inaccuracies contained in the manual, if due to printing or translation errors.

Any supplements to the instruction manual the Customer receives from the Manufacturer must be kept together with the manual, of which they will form an integral part.

B8 Personal protection equipment for use and maintenance

Give below is a summary table of the Personal Protection Equipment (PPE) to be used during the various stages of the appliance's service life.

Stage	Protective garments 	Safety footwear 	Gloves 	Glasses 	Safety helmet 
Transport		X			
Handling		X			
Unpacking		X			
Assembly		X			
Normal use	X	X	X (*)		
Adjustments		X			
Routine cleaning		X	X (*)		
Extraordinary cleaning		X	X		
Maintenance		X			
Dismantling		X			
Scrapping		X			

Key:

X	PPE REQUIRED
	PPE AVAILABLE OR TO BE USED IF NECESSARY
	PPE NOT REQUIRED

(*) During Normal use, gloves protect hands from the contact with chemical substances, water and hot surfaces.

Failure to use the personal protection equipment by operators, specialised technicians or users can involve exposure to chemical risk and possible damage to health.

B9 Keeping the manual

The manual must be carefully kept for the entire life of the appliance until decommissioning.

The manual must stay with the appliance in case of transfer, sale, hire, granting of use or leasing.

B10 Users of the manual

This manual is intended for:

- the carrier and handling personnel;
- installation and start-up personnel;
- the employer of appliance users and the workplace manager;
- operators in charge of normal appliance use;
- specialized technicians - technical assistance (see wiring diagram and service manual).

C GENERAL DESCRIPTION OF THE APPLIANCE

C1 General description

This appliance is suitable for washing items in plastic and/or steel.

The appliance is designed for the above-mentioned applications. Under no circumstances may the appliance be used for other applications or ways not provided for in this manual.

This equipment has been produced to meet the needs for a better work environment and economical efficiency.

The special racks, that can be equipped with various inserts, offer practical and easy use for obtaining excellent washing results. The electronic system enables complete supervision of the washing process. The control panel also has a display that shows the operating parameters and signals any anomalies.

D TECHNICAL DATA

D1 Main technical characteristics

MODELS		EPPWESGFB	EPPWEHGFB	EPPWELGFB
Power supply		Electric	Electric	Electric
Supply voltage:	V	400V 3N~	400V 3N~	400-V 3N~
- convertible to	V	230V 3~	230V 3~	230V 3~
Frequency	Hz	50	50	50
Max. power input	kW	13/20 (*)	13/20 (*)	17/26 (*)
Boiler heating elements	kW	10.5	10.5	10.5
Tank heating elements	kW	7	7	10.5
Steam consumption	kg/h	-	-	-
Maximum steam temperature	°C	-	-	-
Inlet steam relative dynamic pressure	kPa [bar]	-	-	-
Water supply pressure	kPa [bar]	50 - 700 [0,5 - 7,0]	50 - 700 [0,5 - 7,0]	50 - 700 [0,5 - 7,0]
Water supply temp.	°C	50	50	50
Water supply hardness	°f°d/°e	14/8/10 max	14/8/10 max	14/8/10 max
Rinse cycle water consumption	l	7	7	12
Boiler capacity	l	18	18	18
Tank capacity	l	95	95	150
Standard cycle time with water supply at 50°C	sec.	300-480-720	300-480-720	300-480-720
Noise level	dB	<70	<70	<70
Protection rating		IPX5	IPX5	IPX5
Net weight	Kg	215	240	315
Power supply cable		H07RN-F	H07RN-F	H07RN-F

(*) = If activated by software, coincidence of tank and boiler heating elements.

Table 1 Main technical characteristics, performance and consumption

	380-415 V 3N		400-440 V 3		220-230 V 3	
	C	S	C	S	C	S
5 kW	5X1,5 mm ²	16 A 3P+N	-	-	4X1,5 mm ²	16A 3P
9,5 kW	5X4 mm ²	32 A 3P+N	-	-	4X8 mm ²	32A 3P
13 kW	5X4 mm ²	25 A 3P+N	4X4 mm ²	25 A 3P	4X10 mm ²	50A 3P
17 kW	5X6 mm ²	40 A 3P+N	4X6 mm ²	40 A 3P	4X10 mm ²	50A 3P
20 kW	5X6 mm ²	40 A 3P+N	4X6 mm ²	40 A 3P	4X16 mm ²	60A 3P
26 kW	5X10 mm ²	50 A 3P+N	4X10 mm ²	50 A 3P	4X16 mm ²	80A 3P

C = Power supply cable
S = On/Off switch

Standard cycle time may vary should the inlet water temperature be different from that indicated above.

D2 Characteristics of power supply

The AC power supply to the appliance must meet the following conditions:

- max. voltage variation $\pm 10\%$
- max. frequency variation $\pm 1\%$ continuous $\pm 2\%$ for a short period.

Harmonic distortion, unbalanced three-phase supply voltage, voltage pulses, interruption, dips and the other electric characteristics must respect the provisions of point 4.3.2 of Standard EN 60204-1 (IEC 60204-1).



IMPORTANT!

The appliance's power supply must be protected against overcurrents (short circuits and overloads) by fuses or suitable thermal magnetic circuit breakers.

These must be fitted on an omnipolar disconnection system having a contact gap of at least 3 mm.



IMPORTANT!

For protection against indirect contacts (depending on the type of supply provided for and connection of earths to the equipotential protection circuit) refer to point 6.3.3 of EN 60204-1 (IEC 60204-1) with the use of protection devices that ensure automatic cut-off of the supply in case of isolation fault in the TN or TT systems or, for IT systems, the use of isolation controllers or differential current protection devices to activate automatic power disconnection (an isolation controller must be provided for indicating a possible first earth fault of a live part, unless a protection device is supplied for switching off the power in case of a such a fault. This device must activate an acoustic and/or visual signal which must continue for the entire duration of the fault).

For example: in a TT system, a differential switch with cut-in current (e.g. 30 mA) coordinated with the earthing system of the building where the appliance is located must be installed ahead of the supply.



IMPORTANT!

Customers are requested to follow these instructions, otherwise the Manufacturer does not guarantee the appliance for continuous operation and/or against faults.

E TRANSPORT, HANDLING AND STORAGE

E1 Introduction

Transport (i.e. transfer of the appliance from one place to another) and handling (i.e. transfer inside work-places) must occur with the use of special equipment of adequate capacity.

The appliance must only be transported, handled and stored by qualified personnel, who must have:

- specific technical training and experience;
- knowledge of the safety regulations and applicable laws in the relevant sectors;
- knowledge of the general safety provisions;
- the ability to recognize and avoid any possible hazard.

E1.1 Transport: Instructions for the carrier



WARNING!

Do not stand under suspended loads during the loading/unloading phases. Unauthorized personnel must not access the work zone.



IMPORTANT!

The appliance's weight alone is not sufficient to keep it steady.

The transported load can shift:

- when braking;
- when accelerating;
- in corners;
- on particularly rough roads.

E2 Handling

Arrange a suitable area with flat floor for appliance unloading and storage operations.

E2.1 Procedures for handling operations

For correct and safe lifting operations:

- use the type of equipment most suitable for characteristics and capacity (e.g. lift trucks or electric pallet truck);
- cover sharp edges;
- check the forks and lifting procedures according to the instructions given on the packing.

Before lifting:

- send all operators to a safe position and prevent persons from accessing the handling zone;
- make sure the load is stable;
- make sure no material can fall during lifting, and manoeuvre vertically in order to avoid impacts;

- handle the appliance, keeping it at minimum height from the ground.



CAUTION!

For appliance lifting, do not use movable or weak parts such as casings, electrical raceways, pneumatic parts, etc., as anchoring points.

E2.2 Translation

The operator must:

- have a general view of the path to be followed;
- stop the manoeuvre in case of hazardous situations.

E2.3 Placing the load

Before placing the load make sure the path is free and that the floor is flat and can take the load.

E3 Storage

The appliance and/or its parts must be stored and protected against damp, in a non-aggressive place free of vibrations and with room temperature of between -10°C / 14°F and 50°C / 122°F.

The place where the appliance is stored must have a flat support surface in order to avoid any twisting of the appliance or damage to the support feet.



IMPORTANT!

Appliance positioning, installation and disassembly must be carried out by a specialized technician.



IMPORTANT!

Do not make modifications to the parts supplied with the appliance. Any missing or faulty parts must be replaced with original parts.

F

INSTALLATION AND ASSEMBLY



IMPORTANT!

Appliance installation operations must only be carried out by specialized Technicians provided with all the appropriate personal protection equipment (safety shoes, gloves, glasses, overalls, etc.), tools, utensils and ancillary means.

F1 Customer responsibilities

The Customer must provide for the following:

- Install a disconnecting switch with a capacity at least equal to that given in the technical data table, a 30mA residual current circuit breaker and an overcurrent device (magnetothermal cut-out with manual reset or fuse) between the appliance and the mains power outlet. The chosen device must be lockable in the open position in case of maintenance.
- install an adequate electrical power supply ahead of the appliance, according to the equipment's technical specifications (Table 1 and D2 "Characteristics of power supply");
- the equipotential connection of the workplace electrical system to the metal structure of the appliance by means of a copper cable of adequate section (see position "EQ" in par. F6.2 "Installation diagrams");
- Adducting for the electrical connection between the workplace electric panel and the equipment;
- the water supply and drain connections and other connections as indicated in Table 1 and par. F6 "Plumbing connections";

F2 Characteristics of the place of appliance installation

The appliance is designed for installation in professional and not domestic-type kitchens. Water collection traps/metal grates must be arranged in the floor at the appliance discharges (see paragraph F6.2 "Installation diagrams"), possibly replaceable with a single water trap sized for a flow rate of at least 3 l/s.

F3 Appliance space limits

A suitable space must be left around the appliance (for operations, maintenance, etc.).

The passages enabling personnel to operate on the appliance must be at least 50 cm wide, except at the rear of the appliance.

The size must be increased in case of use and/or transfer of other equipment and/or means or if exit routes are necessary inside the workplace.

F4 Positioning

The appliance must be taken to the place of installation and the packing base removed only when being installed.

Arranging the appliance:

- Wear protective gloves and unpack the appliance (Figure 5).

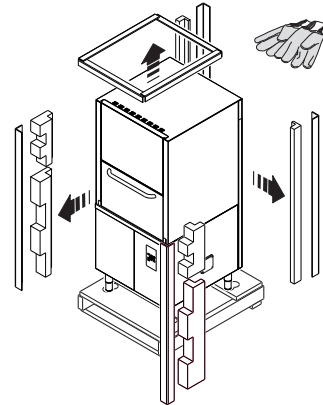

Figure 5 Unpacking

- Lift equipment with a lift truck, inserting the forks as indicated below, remove the base and position the appliance where it is to be installed (Figure 6).

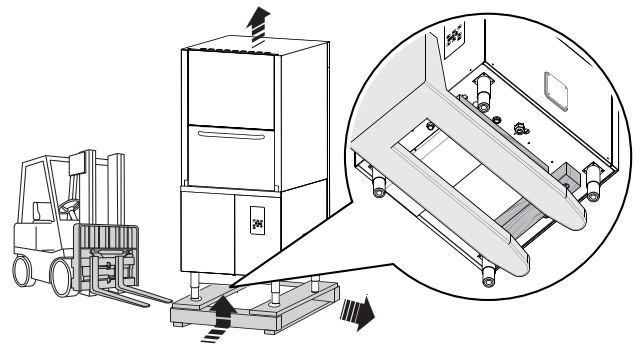

Figure 6 Appliance positioning

- Remove the wooden spacers "A" on the appliance base by undoing the four M8 screws (see Figure 7).

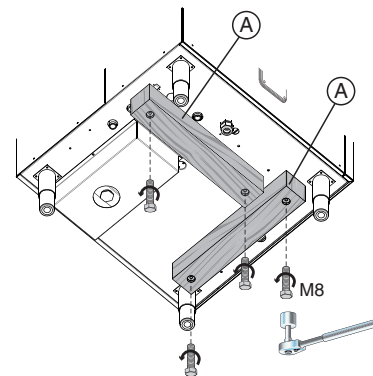

Figure 7 Removal of wooden spacers

- Carefully remove the protective film from the outer panels without tearing it, to avoid leaving traces of glue (Figure 8). .

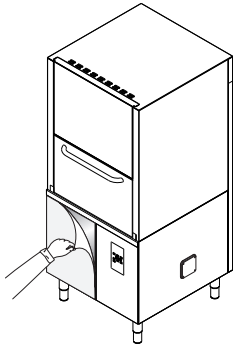

Figure 8 Removing the film

- Adjust the equipment by turning the special adjustable feet and making sure it is perfectly level, both lengthwise and crosswise (Figure 9).

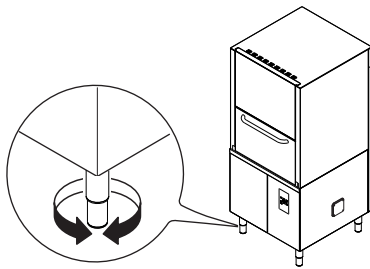

Figure 9 Feet adjustment

F5 Disposal of packing

All materials used for packing are environmentally compatible. They can be safely kept, and recycled or burnt in a special waste incineration plant. Plastic parts subject to possible recycling are marked as follows:



polyethylene: outer wrapping, instruction booklet bag.



polypropylene: roof packing panels, straps.



polystyrene foam: corner protectors.

Parts in wood and cardboard can be disposed of respecting the current regulations in the country of use.

F6 Plumbing connections

Install the appliance water filling and drain pipes according to the plumbing circuit and installation diagrams given below.

- Connect the appliance water supply pipe "HWI" (see paragraph F6.2 Installation diagrams) to the mains, fitting a cut-off cock "X", the filter provided "Y" and a pressure gauge "Z" between the appliance and the mains (Figure 10). Carefully seal all the components to prevent leaks in the pipes.

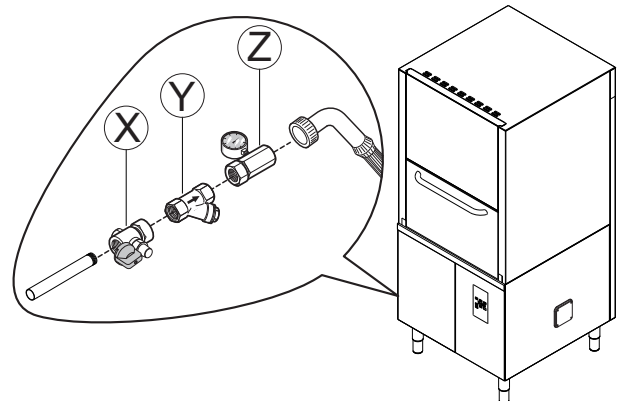
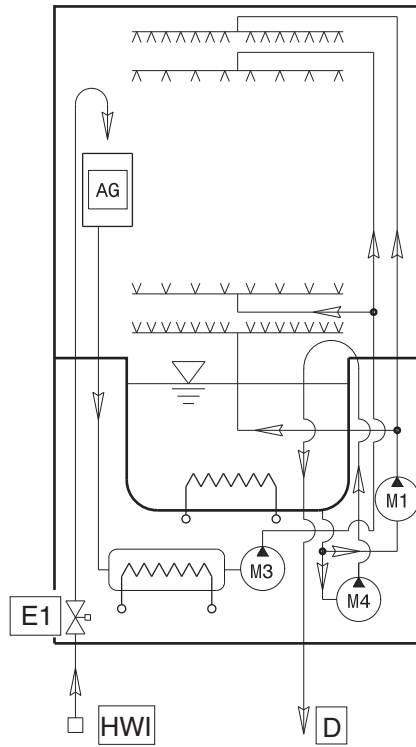

Figure 10 Feed pipe connection

- Check that the **dynamic** water supply **pressure**, measured between the appliance and the main, is **between 50 and 700 kPa** (test while appliance tank or boiler is filling with water). **If the pressure is too high, fit a suitable pressure reducer on the inlet pipe.**
- Connect the waste outlet pipe "D" (see paragraph F6.2 Installation diagrams) to the main drain pipe, fitting a trap, or place the outlet pipe over an S trap set into the floor.

Plumbing circuit diagram for EPPWES / EPPWEH (electric versions)



Plumbing circuit diagram for EPPWEL (electric versions)

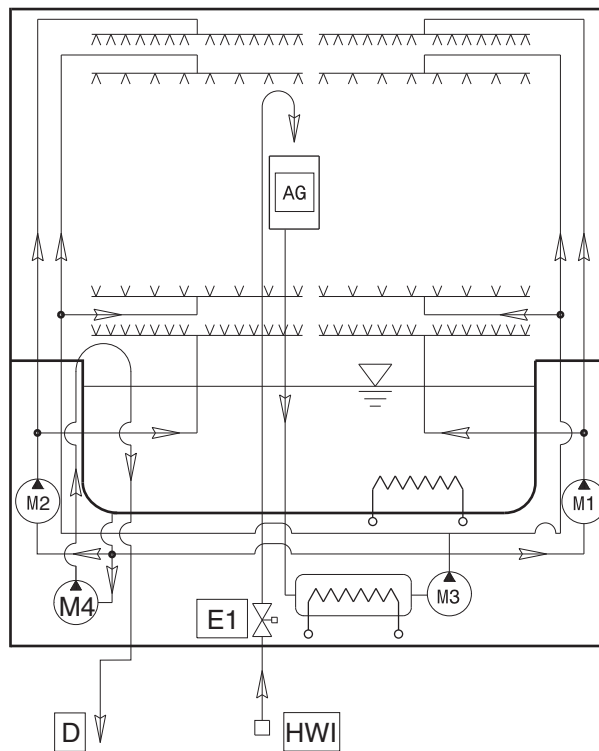

LEGEND

- HWI = Hot water inlet
- M1 = Wash pump
- M2 = Wash pump
- M3 = Rinse pump
- M4 = Drain pump

F6.2 Installation diagrams

The following installation diagrams give the appliance overall dimensions and position of water and electrical connections.



IMPORTANT!

Make sure to install an extractor hood to remove the steam produced by the appliance.

The hood air flow must be calculated taking into account the type of installation and the work environment where it is installed. In any case, an air flow rate of between 1000 m³/h and 1500 m³/h is recommended.

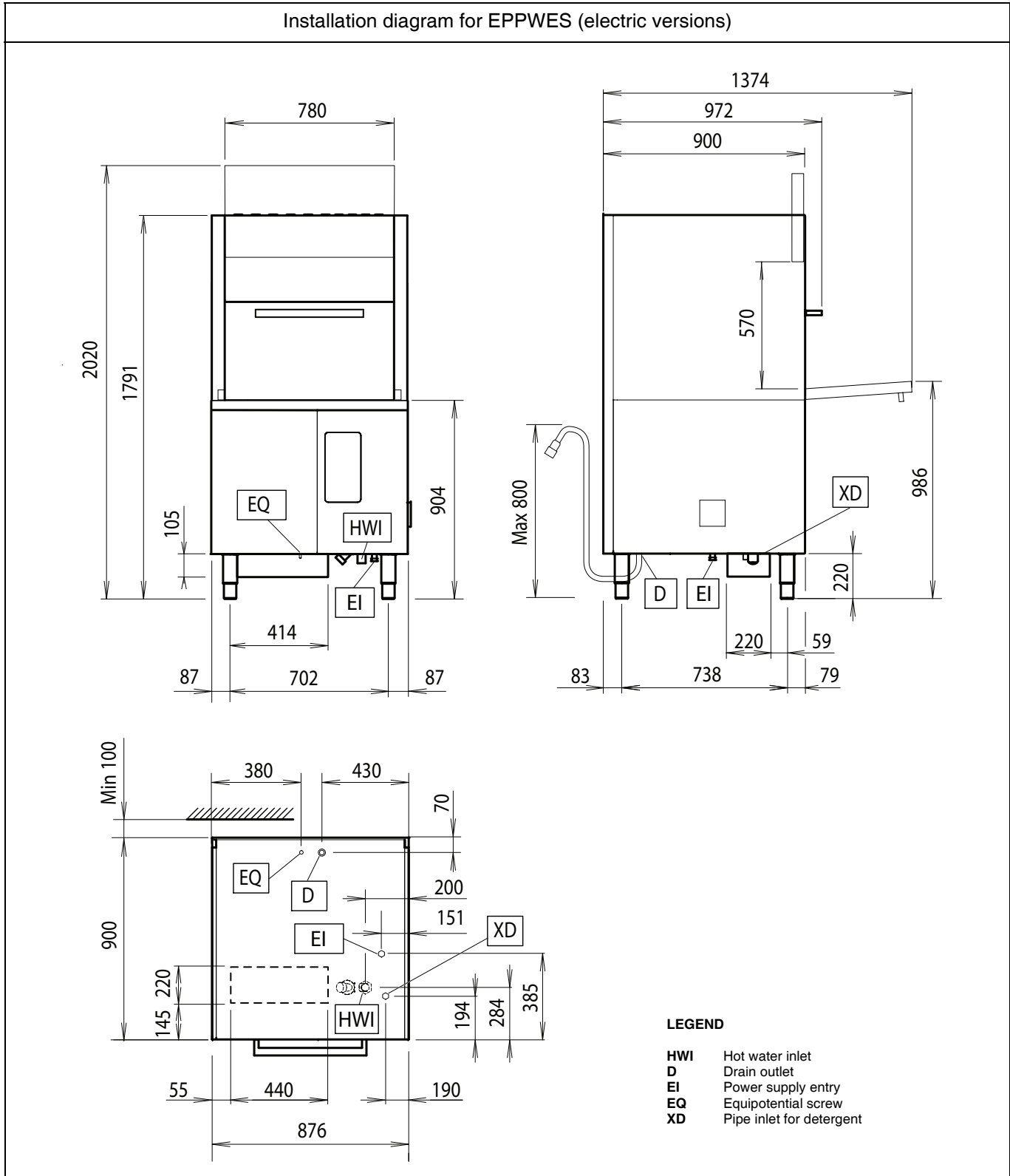

Installation diagram for EPPWEH (electric versions)

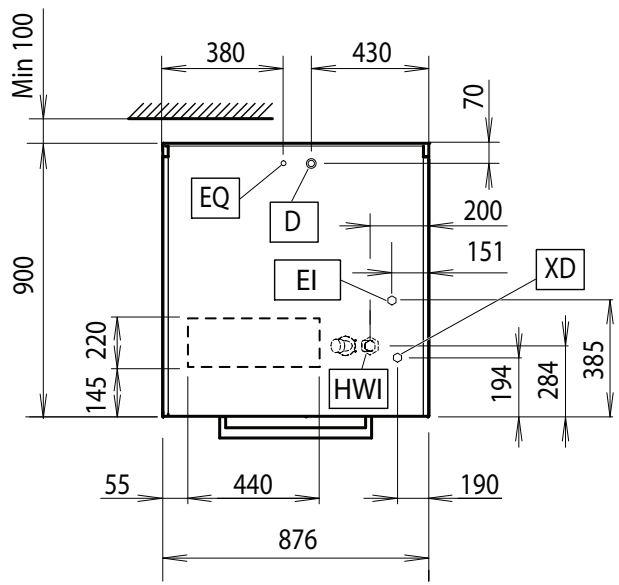
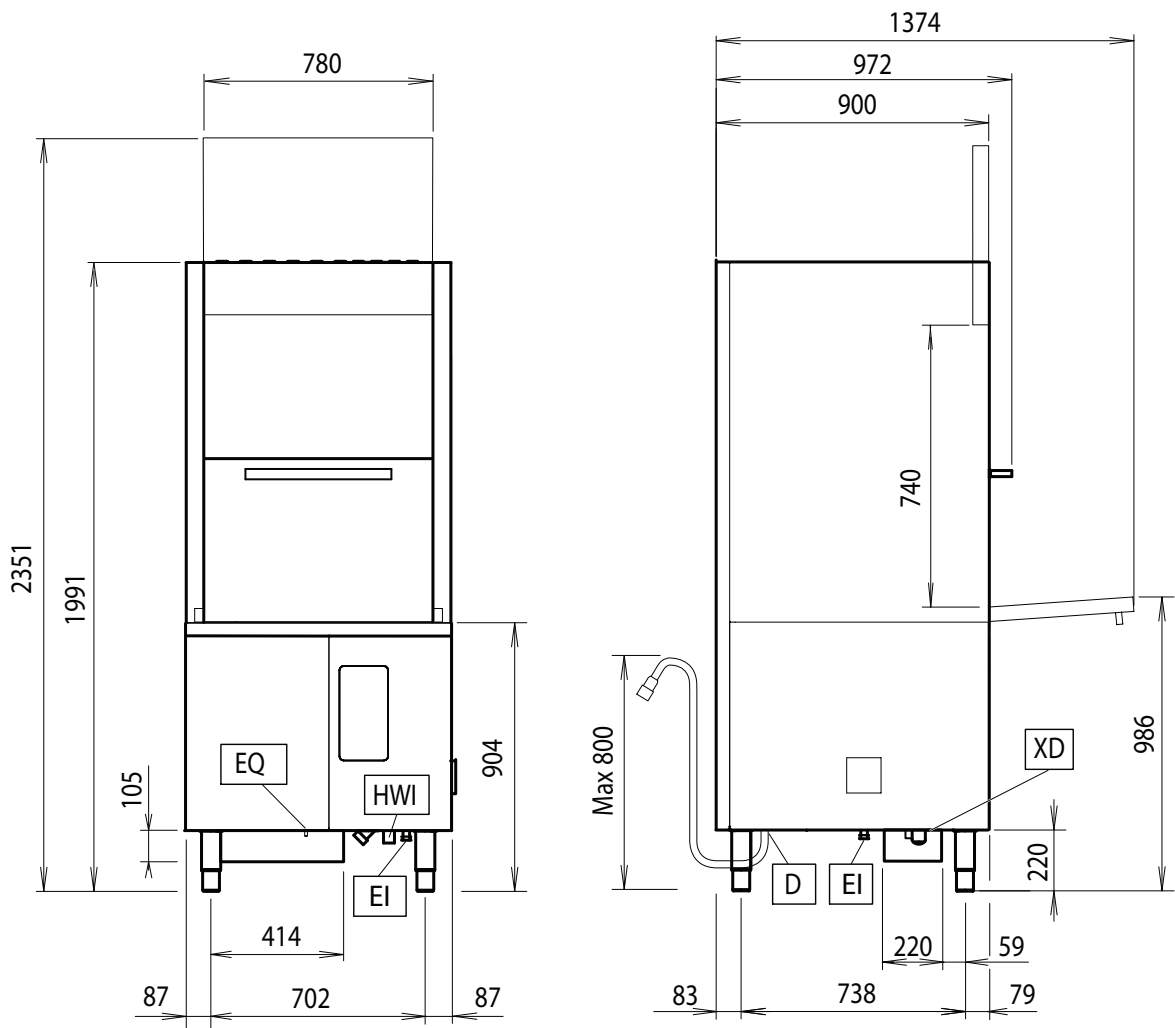

LEGEND

- HWI Hot water inlet
- D Drain outlet
- EI Power supply entry
- EQ Equipotential screw
- XD Pipe inlet for detergent

Installation diagram for EPPWEL (electric versions)

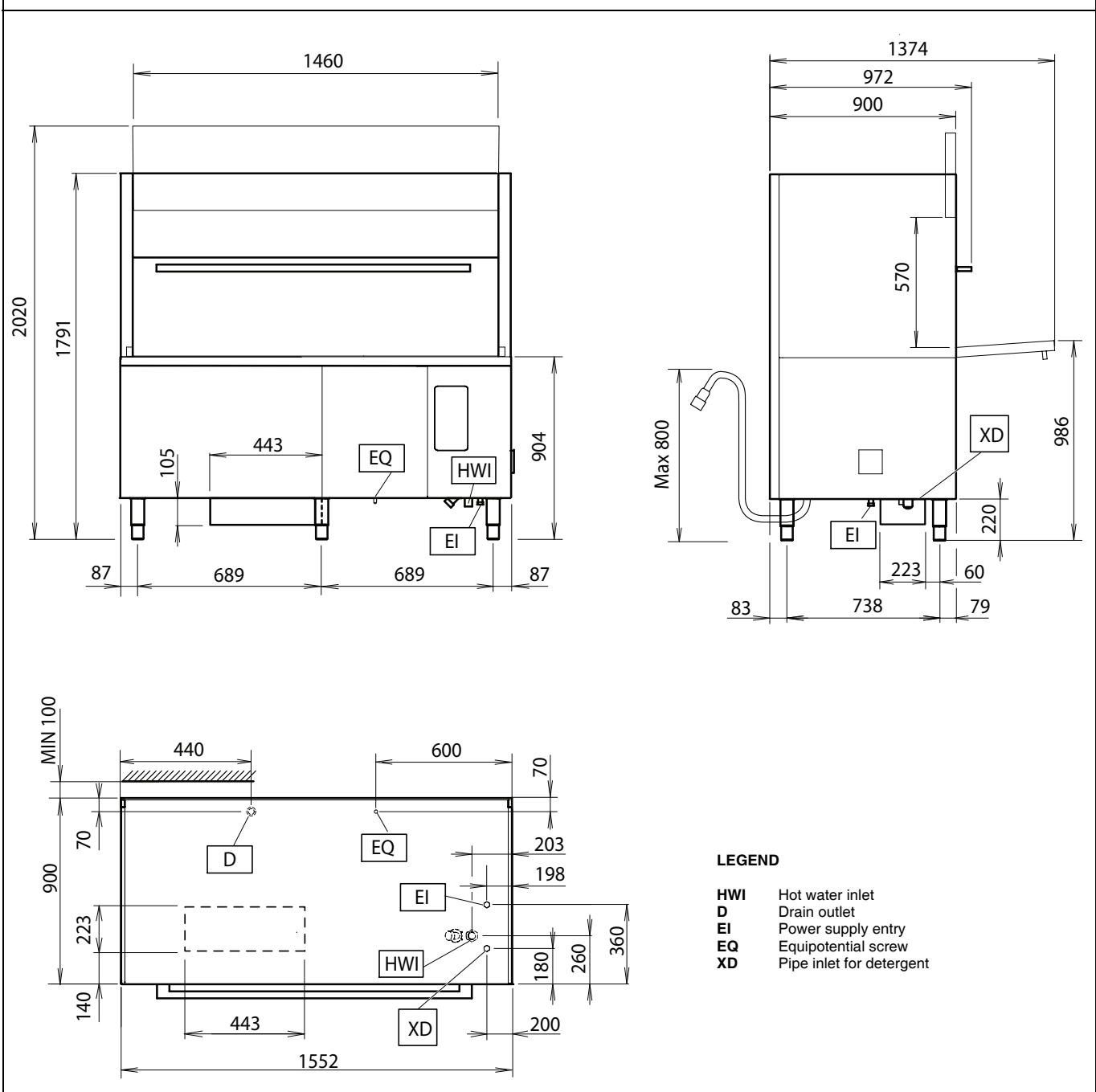

F7 Electrical connections

Connection to the power supply must be carried out in conformity with the current regulations and provisions in the country of use.



IMPORTANT!

Work on the electrical systems must only be carried out by a qualified electrician.

- Make sure the appliance power supply voltage specified on the rating plate (Table 1) matches the mains voltage.
- Make sure the system power supply is arranged and able to take the actual current load and that it is

executed in a workmanlike manner according to the regulations in force in the country of use.

- The earth wire at the terminal end must be longer (max. 20 mm) than the phase wires.
- Connect the earth wire of the power supply cable to an efficient earth clamp. The appliance must also be included in a unipotential system, the connection being made through the screw "EQ" (see paragraph F6.2 Installation diagrams) marked with the symbol "⚡". The unipotential wire must have a cross section of 10 mm².

**Power supply 380-415 V 3N
(standard configuration)**

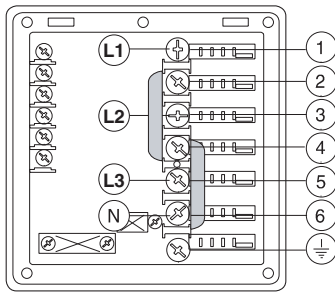

Figure 11 380-415 V 3N

Open the power supply terminal board and insert the jumpers provided as follows: one jumper between terminals 2 and 4 and another between terminals 4 and 6. Using a suitable power supply cable (see technical data table), connect the three phases to terminals 1, 3 and 5, the neutral to terminal 6 and the earth wire to the terminal \perp .

Power supply 400-440V 3

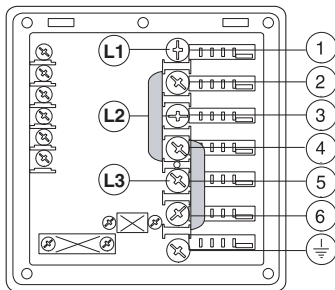

Figure 12 400-440V 3

Open the power supply terminal board and insert the jumpers provided as follows: one jumper between terminals 2 and 4 and another between terminals 4 and 6. Using a suitable power supply cable (see technical data table), connect the three phases to terminals 1, 3 and 5 and the earth wire to the terminal \perp .

Power supply 220-230V 3



CAUTION

These instructions are valid for supply conversion voltage from 380-400V 3N (380-415V three-phase with neutral) to 230V 3~ (230V three-phase without neutral).

Refer to the instructions provided with the appliance to properly execute the voltage convertibility [document number 59967FC00].

Remove the additional electrical wiring harness from wash pump connector and from the main wiring harness.

Connect the main wiring harness directly to the wash pump connector.

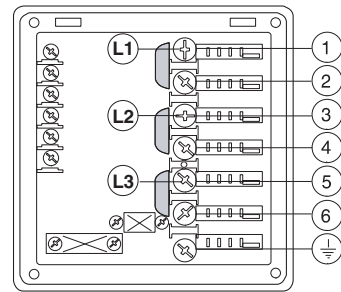

Figure 13 220-230V 3

Open the power supply terminal board and insert the jumpers provided as follows: one jumper between terminals 1 and 2, one between terminals 3 and 4 and another between terminals 5 and 6. Using a suitable power supply cable (see technical data table), connect the three phases to terminals 1, 3 and 5 and the earth wire to the terminal \perp .

F8 Energy control arrangement

The appliance is arranged for external control of energy consumption.

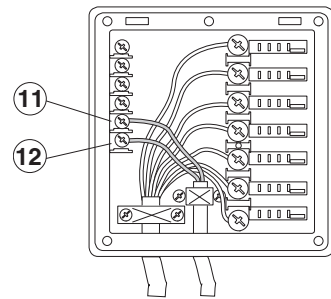

Figure 14 Energy control

Connect the energy peak controller across terminals 11 and 12 (Figure 14).



CAUTION

A normally open (n.o.) contact of the controller must be connected across terminals 11 and 12. When this contact closes the boiler heating elements are disconnected. Using the appliance in these conditions may increase the cycle time.

Safety devices

- An automatic reset thermoamperometric protective device incorporated in the windings of the electric pump cuts off the electricity supply in the case of malfunctioning.
- In the event of water mains failure, a device prevents water in the boiler from returning into the mains.

Failure to comply with safety rules and regulations relieves the manufacturer of all liability.

G DESCRIPTION OF CONTROL PANEL

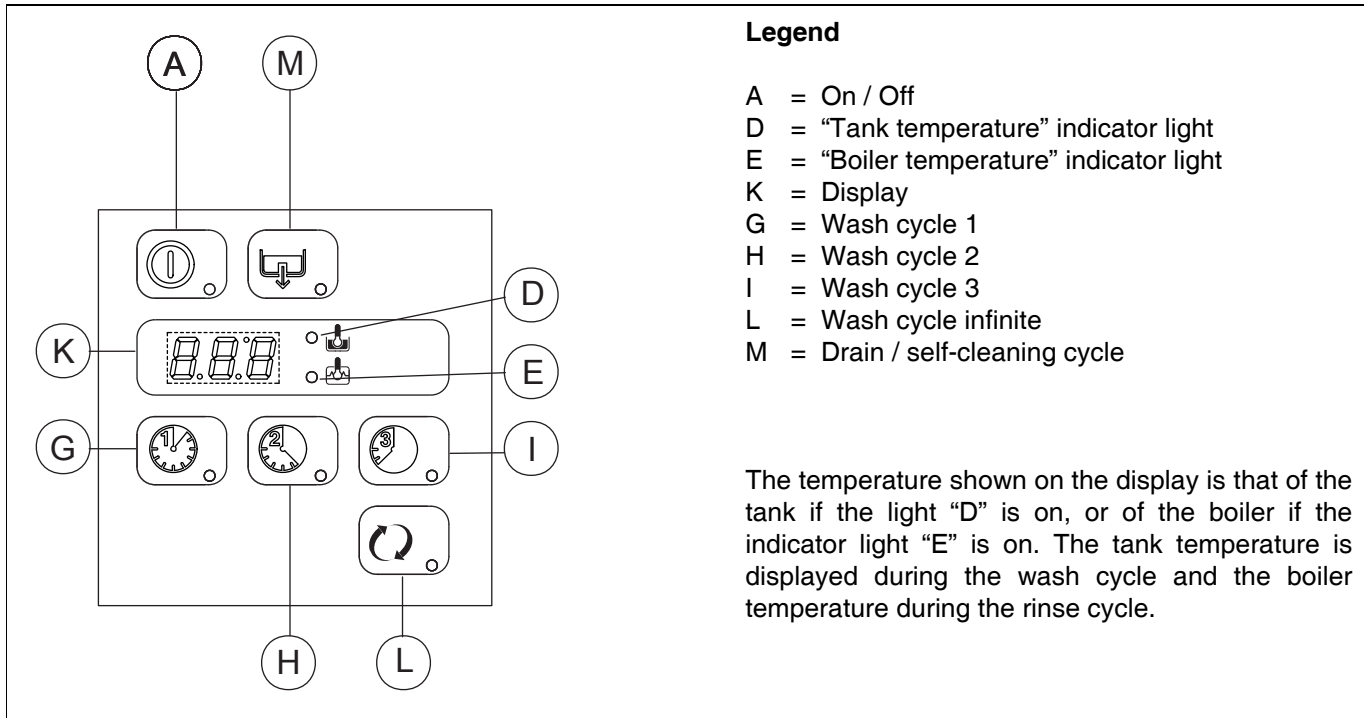

Table 2 Control panel

Described below are all the single buttons and functions present in the control panel shown above.

G1 Basic controls

On/Off



This key indicates the status of the equipment: on or off. When the appliance is on, the key is lit.

Automatic wash cycle 1



This button starts wash cycle 1. This cycle is recommended for washing not very dirty items.

Automatic wash cycle 2



This button starts wash cycle 2. This cycle is recommended for washing normally dirty items.

Automatic wash cycle 3



This button starts wash cycle 3. This cycle is recommended for washing very dirty items.

Wash cycle infinite



This button is used to start a continuous wash that does not stop until the operator selects an automatic cycle. This cycle is recommended for very dirty items with dried residuals, items with particular shapes or for specific user needs.

Drain / self-cleaning cycle



This button starts a drain / self-cleaning cycle. When a cycle is selected, the corresponding button is lit up.

H1 Preliminary checks, adjustments and operational tests



IMPORTANT!

These operations must only be carried out by specialized technicians provided with adequate personal protection equipment (e.g. safety footwear, gloves, glasses, etc.), tools and suitable ancillary equipment.

H1.1 Electrical and plumbing checks

Before starting the appliance:

- check correct connection of the electrical wires that feed the appliance;
- make sure the power supply voltage and frequency match the data given in Table 1;
- check correct connection of the water supply and drain pipes (see par. F6 "Plumbing connections");
- make sure all the guards and safety devices are in place and efficient.

H1.2 Check the positioning of tank components



IMPORTANT!

The following operations must be carried out by operators provided with suitable personal protection equipment (e.g. protective gloves, etc.) with the appliance switched off and cold.

H1.2.1 Check the fitting of filters

Make sure the filters "C" - "D" - "E" are correctly fitted (Figure 15).

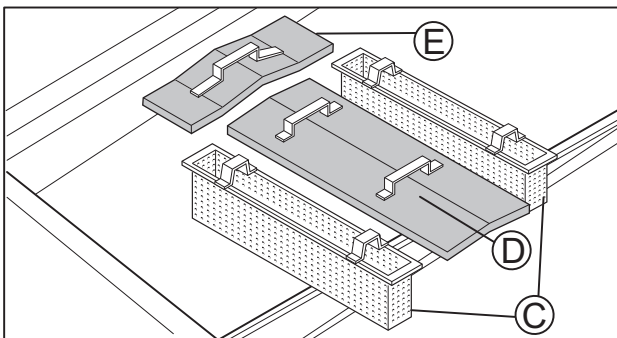

Figure 15 Tank filters

H1.2.2 Arm fitting check

Make sure the upper and lower wash and rinse arms are correctly fitted (Figure 16).

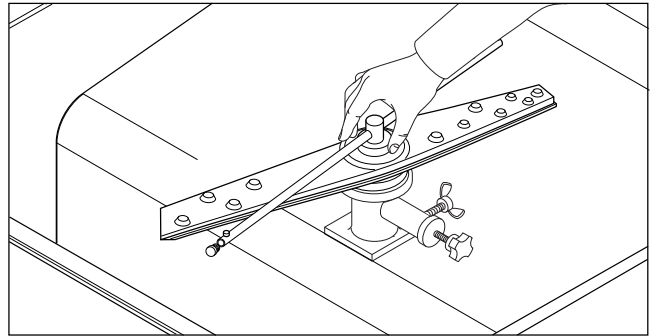

Figure 16 Wash and rinse arms

H2 Starting

- Open the water supply cocks.
- Turn the main switch of the appliance to "I". Press the On/Off key Table 2 ("A" - "Control panel").

H3 Detergent/rinse-aid dispensers and settings

The peristaltic dispensers (detergent and rinse aid) and the tube inside the rinse aid dispenser require periodical maintenance (at least once or twice a year) or after prolonged periods of machine inactivity.

1. Dishwasher with incorporated detergent dispenser pump (Figure 17).

Pump "R" dispenses about 0.9 g/s of detergent. When the appliance is filled with water for the first time in the day, it dispenses about 46 g of detergent in 55 sec., thereby providing a concentration of 2 g/l. Pump "R" dispenses about 4 g in 5 sec. at each cycle.

Dispenser operating time may be changed, following the instructions given in the next paragraph (H4 Setting the dispensers).

Insert the hose provided in the kit into the detergent container.

2. Dishwashers with incorporated peristaltic rinse-aid dispenser pump (Figure 17).

Pump "S" dispenses about 0.1 g/s of rinse-aid. When the appliance is filled with water for the first time in the day, it dispenses about 1,2 g in 11 sec., thereby providing a concentration of 0,1 g/l. Pump "S" dispenses about 0,2 g in 2 sec. at each rinse cycle.

Dispenser operating time may be changed, following the instructions given in the next paragraph (H4 Setting the dispensers).

Insert the hose provided in the kit into the rinse-aid container.

Connections for automatic detergent dispenser (Figure 17)

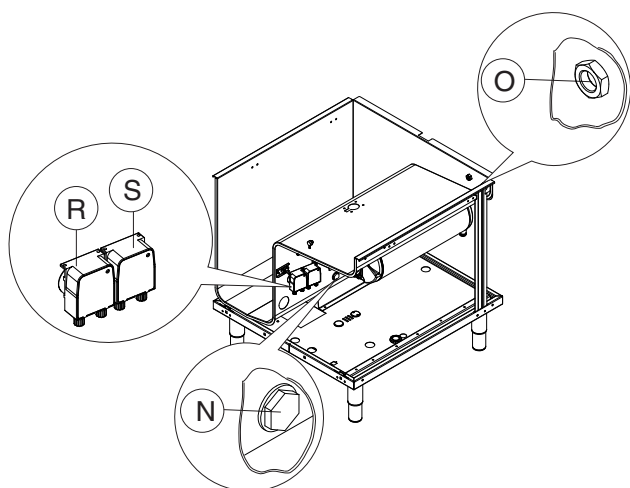

Figure 17 Automatic dispenser arrangement

The wash tank has a (plugged) hole "N" (Ø 22 mm) for fitting a sensor which measures the concentration of detergent.

There is also a (plugged) hole "O" (Ø 22 mm) available for introduction of detergent.

Electrical connections for automatic detergent and rinse-aid dispensers.

Terminals are available on the power supply terminal board for the electrical connection of external dispensers working at 220-240 V. Max. power 30 VA.

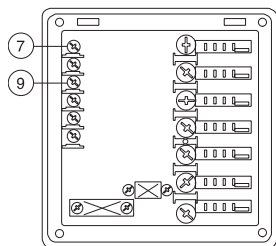

Figure 18 Detergent dispenser terminal block

- Connect the **detergent dispenser** between terminals 7 and 9. These connection points are live for a set time during filling of the tank and at the start of the wash cycle (see paragraph H4 "Setting the dispensers").

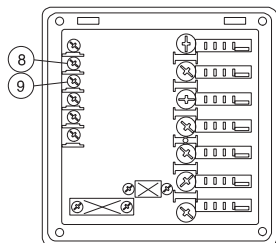

Figure 19 Rinse aid dispenser terminal block

- Connect the **rinse-aid dispenser** between terminals 8 and 9. These connection points are live during filling of the tank and at the end of the rinse cycle for a set time (see paragraph H4 "Setting the dispensers").

Adding the detergent (for models without automatic dispenser).

Pour a non-foaming detergent into the tank when the water has reached optimal washing temperature.

MANUAL ACTIVATION

Whenever the detergent containers are replaced, it may be necessary to activate the dispensers manually in order to fill the hoses and eliminate any air. Simultaneously press the buttons, as shown in the figures below. If necessary, repeat this operation several times.

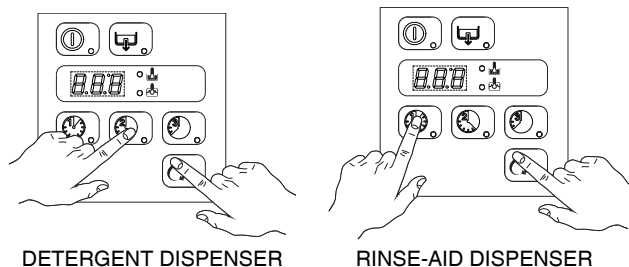

H4 Setting the dispensers

All operations should be carried out with the appliance switched on but no cycle selected.

Press the On/Off button ("A" - Table 2 "Control panel") and Wash cycle 1 button ("G" - Table 2 "Control panel") together for 5 seconds, to access the programming mode and the display shows the parameter "U5r".

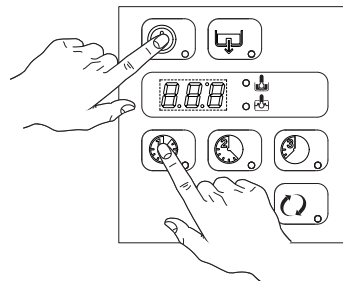

Press the button ("N" - Table 2 "Control panel") twice to access the detergent and rinse aid adjustment parameters.

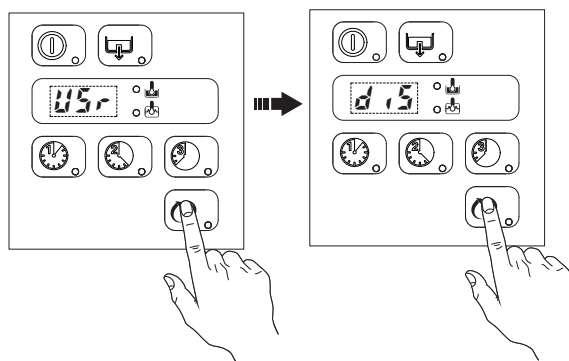

Adjust the following parameters:

Function	Display	Value (*)
Initial amount of detergent	<i>d in</i>	240
Initial amount of rinse-aid	<i>r in</i>	18
Amount of detergent during the cycle	<i>dEt</i>	16
Amount of rinse-aid during the cycle	<i>dEt</i>	7

(*) The values given in the table refer to the factory-settings.

using the Wash cycle 1 button ("G" - Table 2 "Control panel") to decrease the value, the Wash cycle 2 button ("H" - Table 2 "Control panel") to increase the value and the button ("N" - Table 2 "Control panel") to confirm the set value. To go to the next parameter, press the Wash cycle 2 button ("H" - Table 2 "Control panel").

For example, to adjust the parameter *d in*, proceed as follows:

- access the parameter *d in*

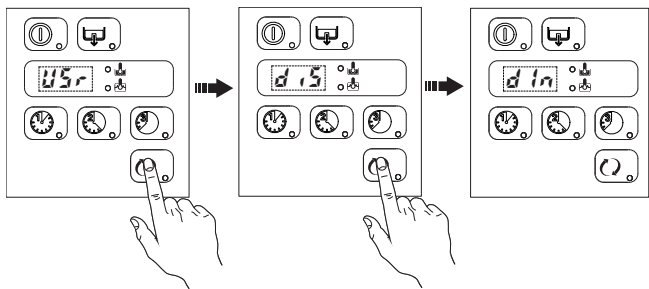

- adjust the activation time:

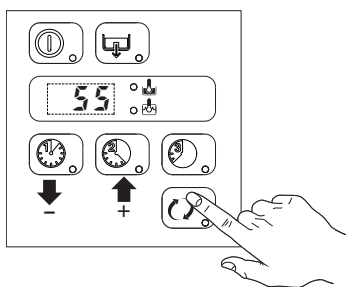

To exit the programming mode, press the Wash cycle 3 button ("I" - Table 2 "Control panel").



Notes for external dispensers:

- if *dEt = 10 1* the **detergent dispenser** only operates during **wash pump** operation; terminals **7-9** of the main terminal board are powered at the same time.
- if *dEt = 10 2* the **detergent dispenser** only operates during **filling electrovalve** operation for restoring the boiler level; terminals **7-9** of the main terminal board are powered at the same time.
- if *rA = 6 1* the **rinse-aid dispenser** only operates during **filling electrovalve** operation for restoring the boiler level; terminals **8-9** of the main terminal board are powered at the same time.
- if *rA = 6 2* the **rinse-aid dispenser** only operates during **wash pump** operation; terminals **8-9** of the main terminal board are powered at the same time.

For connections, see the wiring diagram.

Example:

Supposing that an external detergent dispenser has been connected with a tank concentration measuring sensor, a standard setting could be as follows:

d in = 0 the dispenser is not activated during filling of the tank.

dEt = 10 1 the dispenser is activated during wash pump operation and, thanks to the concentration measured by the conduction sensor, the correct amount of detergent is dispensed.

Suggestion: to check the effectiveness of the rinse-aid, look at freshly washed glasses against the light. Drops of water remaining on the glass indicate an insufficient amount while streaks indicate an excess.

Changing the detergent/rinse-aid type.

If changing to a **different detergent/rinse-aid type** (even one by the same manufacturer), you must rinse the suction and pressure hoses with fresh water before connecting the new detergent/rinse-aid container. Otherwise, the mixing of different types of detergent/rinse-aid will cause crystallisation, which may result in a breakdown of the dosing pump. Failure to observe this condition will invalidate the guarantee and product liability.

GENERAL SAFETY RULES

I1 Introduction

The appliances are provided with electric and/or mechanical safety devices for protecting workers and the appliance itself. Therefore the user must not remove or tamper with such devices.

The Manufacturer declines any liability for damage due to tampering or their non-use.

I1.1 Protection devices installed on the appliance

I1.1.1 Guards

The guards on the appliance are:







- fixed guards (e.g. casings, covers, side panelling, etc.), fixed to the appliance and/or frame with screws or quick-release couplings that can only be removed or opened with tools;
- interlocked movable guards (front panels) for access to inside the appliance;
- access doors to the appliance's electrical equipment, made from hinged panels openable with tools. The door must not be opened during appliance movement, if inside the door there is equipment that is hazardous when live or under pressure.



IMPORTANT!

Several illustrations in the manual represent the appliance, or parts of it, without guards or with guards removed. This is purely for explanatory requirements. Never operate the appliance without the guards or with the safety devices deactivated.

I1.2 Safety signs to be displayed on the appliance or near the work area

		MEANING
P R O H I B I T I O N		Do not oil, lubricate, repair and adjust moving parts.
		Do not remove the safety devices.
		Do not use water to extinguish fires (shown on electrical parts).
D A N G E R		DANGER OF CRUSHING HANDS
		DANGER OF BURNS
		DANGER OF ELECTROCUTION (shown on electrical parts with indication of voltage).



WARNING!

Do not remove, tamper with or make the labels on the appliance illegible.

I2 Decommissioning

When the appliance is no longer to be used, make it unusable by removing the feed wiring from the power supply and the water connections.

I3 Instructions for use and maintenance

Risks mainly of a mechanical, thermal and electrical nature are present in the appliance.

Where possible the risks have been neutralized:

- directly, by means of adequate design solutions,
- or indirectly by using guards, protection and safety devices.

Any anomalous situations are signalled on the control panel display.

During maintenance several risks remain, as these could not be eliminated and which must be neutralized through specific behaviour and precautions.

Do not carry out any control, cleaning, repair or maintenance operations on moving parts.

Workers must be informed of the prohibition by means of clearly visible signs.

To guarantee appliance efficiency and correct operation, periodical maintenance must be carried out according to the instructions given in this manual.

In particular, make sure to periodically check correct operation of all the safety devices and the insulation of electrical cables, which must be replaced if damaged.



IMPORTANT!

Appliance maintenance operations must only be carried out by specialized Technicians provided with all necessary personal protection equipment (safety shoes, gloves, glasses, overalls, etc.), tools, utensils and suitable ancillary means.



WARNING!

Never operate the appliance by removing, modifying or tampering with the guards and protection or safety devices.



IMPORTANT!

Before carrying out any operation on the appliance, always consult the manual which gives the correct procedures and contains important information on safety.

14 Improper use

Improper use is any use differing from that specified in this manual. During appliance operation, other types of work or activities considered improper and that in general can involve risks for the safety of operators and damage to the system are not allowed.

Improper use includes:

- failure to disconnect the power supply with the main switch in “O” off position before carrying out adjustment, cleaning, resetting and maintenance operations;
- failure to disconnect the power supply with the main switch in off position “O” at the end of the day;
- lack of appliance maintenance, cleaning and periodical checks;
- structural changes or modifications to the operating logic;
- tampering with the guards or safety devices;
- failure to use personal protection equipment by operators, specialized technicians and maintenance personnel;
- failure to use suitable accessories (e.g. use of equipment, ladders, etc., unsuitable for carrying out maintenance on equipment positioned inside the appliance);
- keeping combustible or flammable materials, or in any case materials not compatible with or pertinent to the work, near the appliance;
- incorrect appliance installation (see chapter E “Installation and assembly”);
- placing in the appliance any objects or things not compatible with washing or that can obstruct/damage the appliance or persons or pollute the environment;
- non-compliance with the requirements for correct appliance use;

- other actions that can cause risks not eliminable by the Manufacturer.

15 Residual risks

The appliance has several risks that were not completely eliminated from a design standpoint or with the installation of adequate protection devices.

Nevertheless, through this manual the Manufacturer has taken steps to inform operators of such risks, carefully indicating the personal protection equipment to be used by them.

Sufficient spaces are provided for during the appliance installation phases in order to limit these risks.

To preserve these conditions, the corridors and areas around the appliance must always be:

- kept free of obstacles (e.g. ladders, tools, containers, boxes, etc.);
- clean and dry;
- well lit.

For the Customer’s complete information, the residual risks remaining on the appliance are given below; such actions are to be considered incorrect and therefore strictly forbidden.

APPLICATION PHASE: I=Installation, U=Normal use, M=Maintenance, P=Cleaning.

RESIDUAL RISK	DESCRIPTION OF HAZARDOUS SITUATION
Slipping or falling [U - M]	The operator can slip due to water or dirt on the floor.
Burns [U - M - P]	The operator deliberately or unintentionally touches some components inside the appliance or dishes at the outfeed without using gloves or without allowing them to cool.
Electrocution [M]	Contact with live parts during maintenance operations carried out with the electrical panel powered. The operator intervenes (with a power tool or without disconnecting the power to the appliance) lying down on the wet floor.
Falling from above [I - U - M]	The operator intervenes on the appliance using unsuitable systems to access the upper part (e.g. rung ladders, or climbs on it).
Tipping of loads [I - M]	During maintenance on the appliance or the packing containing the appliance with the use of unsuitable accessories or lifting systems or with load unbalanced.
Chemical [I - U - M - P]	Contact with chemical substances (e.g. detergent, rinse aid, scale remover, etc.) without taking adequate safety precautions. Therefore always refer to the safety cards and labels on the products used.
Crushing or shearing [I - U - M]	Possible risk of injury to upper limbs during the door closing operation.

Table 3 Residual risks

J NORMAL APPLIANCE USE

J1 Correct use

Our appliances are designed and optimized in order to obtain high performance and efficiency. This equipment must only be used for its expressly designed purpose, i.e. washing items with water and specific detergents. Any other use is to be deemed improper.

J2 Characteristics of personnel enabled to operate on the appliance

Operator qualified for normal use must have at least:

- knowledge of the technology and specific experience in operating the appliance;
- adequate general basic education and technical knowledge for reading and understanding the contents of the manual,
- the capacity for a correct interpretation of the drawings, signs and pictograms;
- sufficient technical knowledge for safely performing his duties as specified in the manual;
- knowledge of the regulations on work hygiene and safety.

In the event of a significant anomaly (e.g. short circuits, wires coming out of the terminal block, motor breakdowns, worn electrical cable sheathing, etc.) the operator qualified for normal appliance use must:

- immediately deactivate the appliance by turning the main switch to "O" ;
- close the appliance water supply by shutting off the water.

J3 First use

Carry out a couple of cycles without items to flush out any industrial grease which has remained in the tank and piping.

J4 Daily activation of appliance

- Make sure the filters and the arms are correctly fitted according to that indicated in par. H1.2 "Check the positioning of tank components" and F8 "Energy control arrangement".
- Open the water supply cocks.
- Activate the main switch by turning it to position "I".
- Open the door and check that all the components are in their correct position.
- Close the door.
- Switch on the appliance by pressing the button "A".



The button "A" lights up (Table 2 "Control panel"), indicating that the appliance is powered and that water is being introduced and heated.

The word "FILL" is shown on the display during the entire filling and heating stage:



Warning, this appliance does the first tank filling through several consecutive hot rinse cycles, while the display shows the message FILL (flowing).

This system let save up to 30% of time than traditional models.

If the door is opened during this stage the message "CLOSE" will appear on the display:



The filling and heating stage has finished when the display shows the tank temperature:



To display the boiler temperature during heating of the tank, open the door and press the button "G" (Table 2 "Control panel").



J5 Wash cycles

The wash cycle includes a wash with hot water and detergent at a temperature of at least 55°C/ 131°F and a rinse with hot water and rinse aid (min. 82°C / min. 180°F).

Table of times

Standard cycle time with supply water at 50 °C :

	I	II	III	IV
EPPW	5 min	8 min	12 min	INFINITE

A device lengthens the cycle time if the water in the boiler has not reached the minimum temperature for correct rinsing.

The cycle times and the temperature may be personalised (e.g. increase of the rinse time and temperature).

The cycle times should only be set by a specialised technician.

J6 Operation

The filling and heating stage has finished when the display shows the tank temperature:



The appliance is then ready for use:

- Open the door.
- Pour the required amount of detergent non-foaming into the tank.
- Insert the dirty items and containers upside down on the basket.
- Arrange items in the rack.

Increase / decrease the water pressure

For washing light items:

- unscrew the wing nut "X" (Figure 20);
- press the limiting valve "Y" (Figure 20) inward to reduce the water pressure in the lower wash arm and thus increase the water pressure in the upper wash arm, so that the items remain in their position.
- retighten the wing nut "X" (Figure 20).

For washing large and heavy items:

- unscrew the wing nut "X" (Figure 20);
- remove the limiting valve "Y" (Figure 20);
- retighten the wing nut "X" (Figure 20).

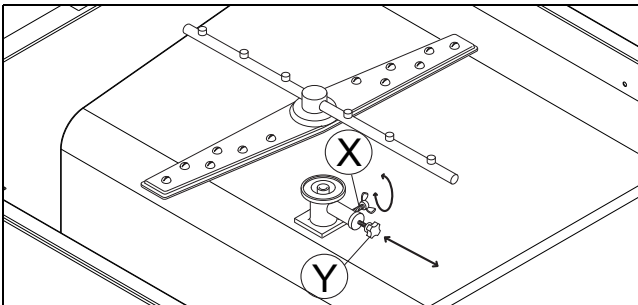

Figure 20 Wash water pressure adjustment

- Close the door and select the suitable wash cycle; the corresponding indicator light comes on and the wash cycle starts.

Usable wash cycles:

- Automatic cycle I

For lightly soiled items: press button "G" (see Table 2 "Control panel" and table of times).



- Automatic cycle II (recommended)

For normally dirty items: press button "H" (see Table 2 "Control panel" and table of times).



- Automatic cycle III

For very dirty items: press button "I" (see Table 2 "Control panel" and table of times).



- Manual cycle IV

For particularly heavy dirty items or for other specific needs of the user: press button "L" (see Table 2 "Control panel"), which initiates a continuous wash until the operator selects an automatic cycle.



- To stop the wash cycle, just press the selected cycle button or open the door.
- To continue the wash cycle, just press the selected cycle button or close the door. The cycle starts again from where it stopped.
- At the end of the wash, the appliance emits a series of beeps and "END" blinks on the display:



open the door and remove the basket containing the clean items.

IMPORTANT

The use of "foaming"/non-specific detergents or in any case detergents used in different ways from that prescribed by the manufacturer, can cause damage to the appliance and compromise washing results.

IMPORTANT

Failure to remove the residuals of detergent possibly used for manual prewash can cause malfunctioning of the appliance and compromise washing results.

Change the water in the tank at least twice a day.

Loading the racks provided

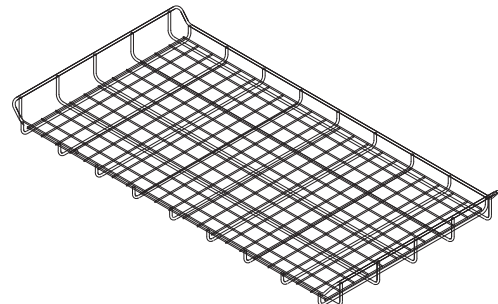

Figure 21 Basket for items

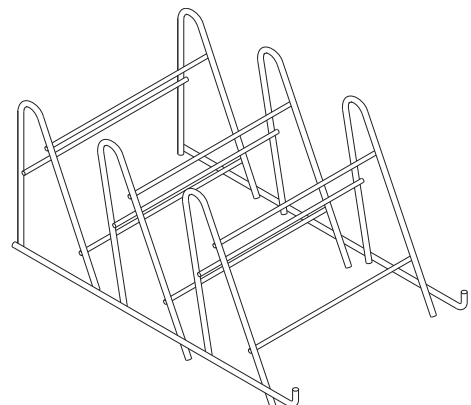

Figure 22 Tray rack

J7 Alarms

In case of a generic appliance fault, the display shows the relevant alarm code.

For example:



List of possible documented appliance alarms with respective cause / cure.

Code	Description	Cause / Solution
A1	NO WATER	Check that the cock is open. Check that the water inlet filter is clean. Check the minimum mains pressure.
B1	INEFFICIENT DRAINAGE	Check for obstruction on the waste outlet pipe.
B2	TANK WATER LEVEL TOO HIGH	Check for obstruction on the waste outlet pipe.
C1..C9	CALL THE SERVICE CENTRE	
E1..E8	CALL THE SERVICE CENTRE	The appliance continues to operate, but appropriate checks by a technician are recommended.

J8 Appliance cleaning

Cleaning must be carried out after every day of use. Use hot water, a neutral detergent/deterative if necessary, and a soft brush or sponge. If another type of detergent is used carefully follow the manufacturer's instructions and observe the safety rules given in the information cards provided with the product or substance.

In order to reduce the environmental impact of pollutant substances, clean the equipment (externally and internally where necessary) with products that are more than 90% biodegradable.



CAUTION!

Do not use steel wool or similar material to clean s/steel surfaces. Do not use detergents containing chlorine.



CAUTION!

Contact with chemical substances (e.g. detergent, rinse aid, scale remover, etc.) without taking appropriate safety precautions (e.g. personal protection equipment) can involve exposure to chemical risk and possible damage to health. Therefore always refer to the safety cards and labels on the products used.

J8.1 End of service and daily internal cleaning

The appliance is designed to carry out an automatic cleaning cycle to help flush out any residues and to guarantee greater health and hygiene.

Cleaning the tank

- Open the door and pull out the rack with the clean items.

- Release the door for access to the tank (Figure 23):
 - Lift the latch "S" and pull the door slightly outward.
 - Lift the latch "T" and pull the door slightly outward.
- Remove the door by pulling it outward, making sure it does not get stuck.

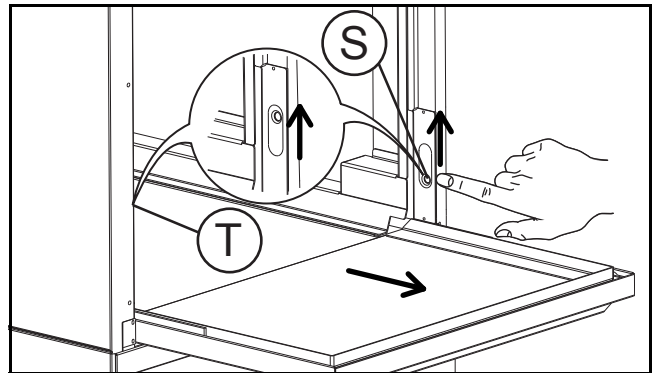

Figure 23 Release the door

- Gently lower the door.
- Remove the tank filters "C" - "D" - "E" (Figure 24).

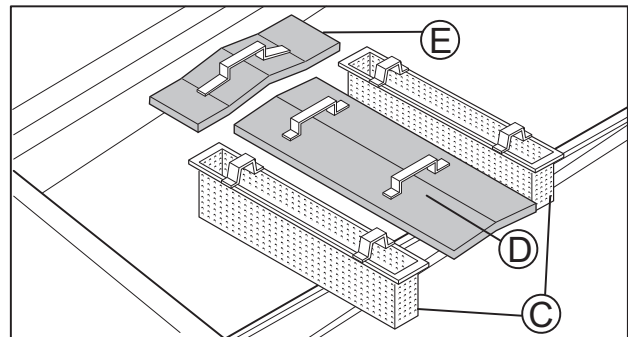

Figure 24 Tank filters

- Clean the filters under a water spray using a nylon brush.
- Refit the door (Figure 25):
 - Lift the door as far as movement permits (horizontal).
 - Push the door inward, making sure it does not get stuck, until the latches "S" and "T" are both lowered in the initial position (all down). This operation is correctly done when the door cannot be pulled outward on the side of latch "S" and that of latch "T".

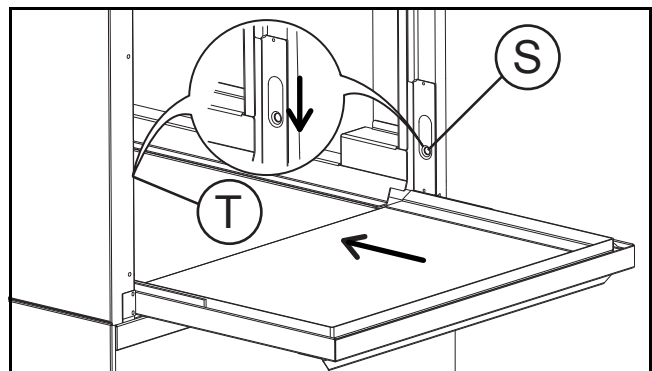

Figure 25 Refit the door

- Close the door, gently lifting it.
- Select the drain cycle by pressing button "M" (Table 2 "Control panel").



The message "CLE" ("CLEAN") will be displayed throughout the drain cycle:



- After a few minutes, 3 beeps indicate the end of the cleaning cycle and "END" blinks on the display:



- Switch off the appliance by pressing button "A" (Table 2 "Control panel").



- Switch off at the mains.
- Close the water supply cock.
- Before operating the appliance again, replace the components that have been removed.

Cleaning the nozzle jets

- Remove the upper and lower wash arms "F" and rinse arms "I", undoing the ring nut "H" (Figure 26).

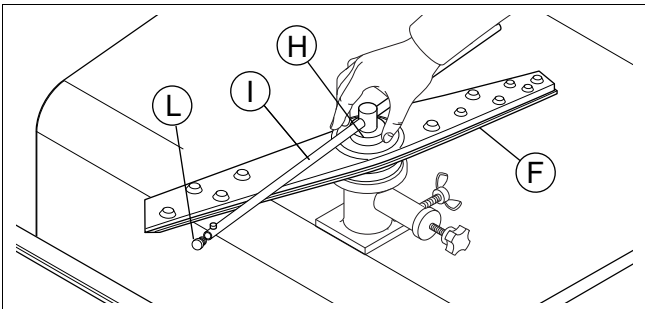

Figure 26 Rotating wash arms and rinse arms

- Unscrew plugs "L" (Figure 26) from the rinse jets.

IMPORTANT

Descal the rinse jets "I" (Figure 28) every month using vinegar or a descaling agent.

- Remove jet "P" (Figure 27) by turning it clockwise and pulling it out.
- Unscrew plugs "R" (Figure 27) from the side jets.

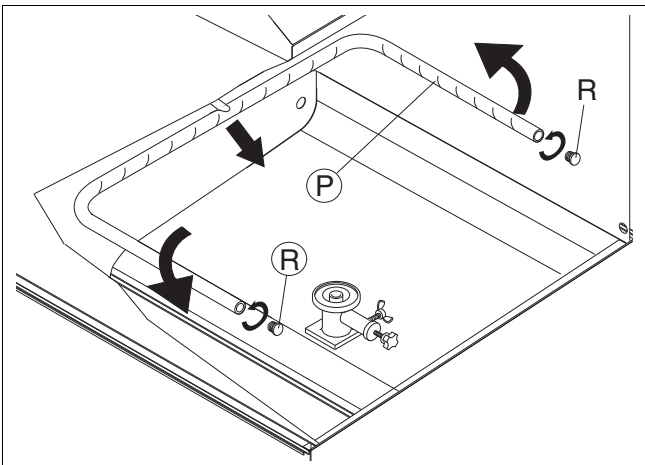

Figure 27 Fixed wash arm removal

- Carefully clean the washing and rinse jets and clean everything with hot water and neutral detergent/detergent, if necessary using a soft brush or sponge. In particular, for the jet "P" (Figure 28) use warm water and detergent, and a soft brush "Z" if necessary (Figure 28). Do not use sharp implements to clean the nozzle holes, which could otherwise be damaged.

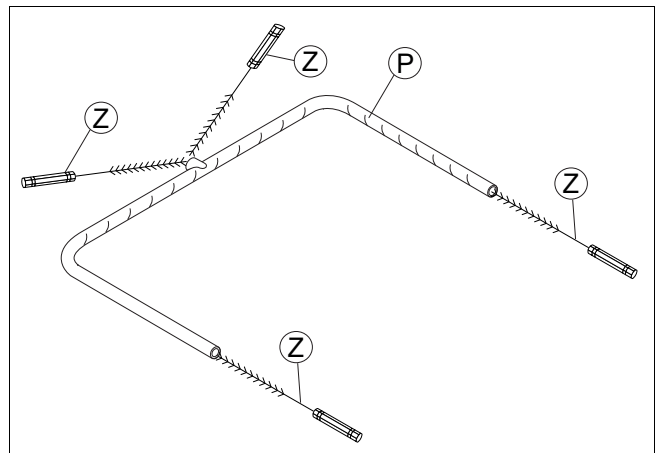
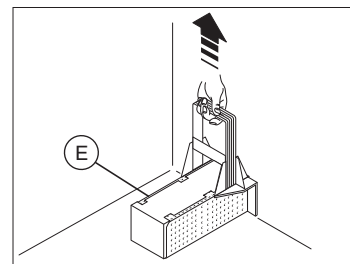

Figure 28 Fixed wash arm cleaning

Cleaning the wash pump filter

- Remove the filter "E" and clean away any remained food.



Upon completion of cleaning operations, replace the parts removed previously.

J8.2 Exterior cleaning

Before carrying out any cleaning operations, turn off the power at the mains.

IMPORTANT

Clean the stainless steel surfaces using warm soapy water; never use detergents containing abrasive substances nor steel scrapers, common wire wool, brushes or scrapers; rinse thoroughly using a wet cloth and carefully wipe dry. Clean the control panel using a soft damp cloth and a neutral detergent if necessary.

To reduce the emission of pollutants into the environment, clean the appliance (externally and where necessary internally) with products having a biodegradability of over 90%.

Leave the hood raised whenever the appliance is not in use.

J9 Long idle periods

Whenever the appliance is not going to be used for a long period of time (e.g. one month), carefully carry out the following instructions.

- Close the water supply cock.
- Completely drain the tank and carry out a cleaning cycle (see instructions in the paragraph J8.1 “End of service and daily internal cleaning”)
- Remove and carefully clean the filters.
- Completely drain the incorporated dispenser hoses, removing them from the containers. Repeat the procedure described in the paragraph “Manual activation” at least 3 times.
- Completely drain the boiler by simultaneously pressing the buttons as shown in the figure

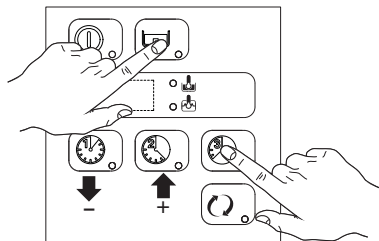

- A buzzer indicates completion of drainage.
- Clean the inside and outside of the appliance as indicated in par. J8.1 “End of service and daily internal cleaning” and J8.2 “Exterior cleaning”.
- Spread a film of paraffin oil over the steel surfaces.

When using the appliance again, follow the indications in par. J4 “Daily activation of appliance”.

J10 Maintenance

Inspection and maintenance intervals depend on the actual appliance operating conditions (total wash hours) and ambient conditions (presence of dust, damp, etc.), therefore precise time intervals cannot be given. In any case, to minimize interruptions of the service, careful and periodical appliance maintenance is advisable.

Therefore, it is advisable to:

- Descale the boiler, inside surfaces of the tank and the appliance piping once or twice a year (call technical assistance).
- Every month descale the wash and rinse jets with vinegar or scale remover.
- The internal hose of the rinse-aid and detergent peristaltic dispenser should undergo periodic maintenance (once or twice a year).
- Clean the water filter installed on the supply inlet pipe, and the solenoid valve protection filter at least twice a year (call technical assistance).

It is also advisable to stipulate a scheduled preventive maintenance contract with technical assistance.

J10.1 Preventive maintenance

The preventive maintenance call can be activated (call technical assistance).

On reaching the set number of cycles (e.g. 20000), a technical assistance call message appears on the display.

This message suggests calling a specialized technician, for a general check of the equipment.

J11 Appliance disposal

At the end of the product’s life cycle, make sure the equipment is not dispersed in the environment. The equipment must be disposed of in compliance with current regulations in the country of use.

All metal parts are in s/steel (AISI 304) and removable. Plastic parts are marked with the letters of the material.

The symbol  on the product indicates that this product should **not** be treated as domestic waste, but must be correctly disposed of in order to prevent possible negative consequences for the environment and the human health.

Regarding the recycling of this product, please contact the sales agent or dealer of your product, your after-sales service or the appropriate waste disposal service.

J12 Troubleshooting

THE APPLIANCE DOES NOT WASH WELL
<ol style="list-style-type: none">1. Check if the suction filter is dirty and clean it thoroughly.2. Check if the wash jets are clogged and clean them.3. Check that the initial amount of detergent or subsequent additions are correct.4. The selected wash cycle is too short. Repeat the cycle.5. Check that the tank temperature is at least 55°C / 131°F.6. Check that the items are stacked correctly in the racks.
OBJECTS ARE NOT DRIED PROPERLY
<ol style="list-style-type: none">1. Check that there is rinse-aid in the container and if necessary top up.2. Check the set amount of rinse-aid (see “setting the dispensers” paragraph).3. Check that the water temperature is between 80°C and 90°C.
CONDENSATION ON OBJECTS
<ol style="list-style-type: none">1. Check that there is rinse-aid in the container and if necessary top up.2. Check the set amount of rinse-aid (see “setting the dispensers” paragraph).3. Remove the rack of glasses immediately the cycle has ended.
STAINS ON THE OBJECTS
<ol style="list-style-type: none">1. Only use “non-foaming” products for professional dishwashers.

EXCESSIVE FOAM IN THE TANK

1. Check that the wash water temperature is not less than 55°C / 131°F.
2. Check if the amount of product dispensed by the detergent dispenser is excessive (see “setting the dispensers” paragraph).
3. Ensure that the tank has not been cleaned with unsuitable cleaners. Drain the tank and rinse thoroughly before new wash cycles.
4. If a foaming detergent has been used, drain and refill the tank with water until the foam disappears.

SMEARS OR SPOTS ON THE OBJECTS

1. Reduce the amount of rinse-aid (see “setting the dispensers” paragraph).

THE WASH OR RINSE ARMS TURN SLOWLY

1. Remove and thoroughly clean the arms.
2. Clean the wash pump suction filter.

