

Rack type dishwasher

Multi-Rinse



EN Installation manual *



*Original instructions

59566P401- 2019.07

Installation diagram
150 racks/hour right to left

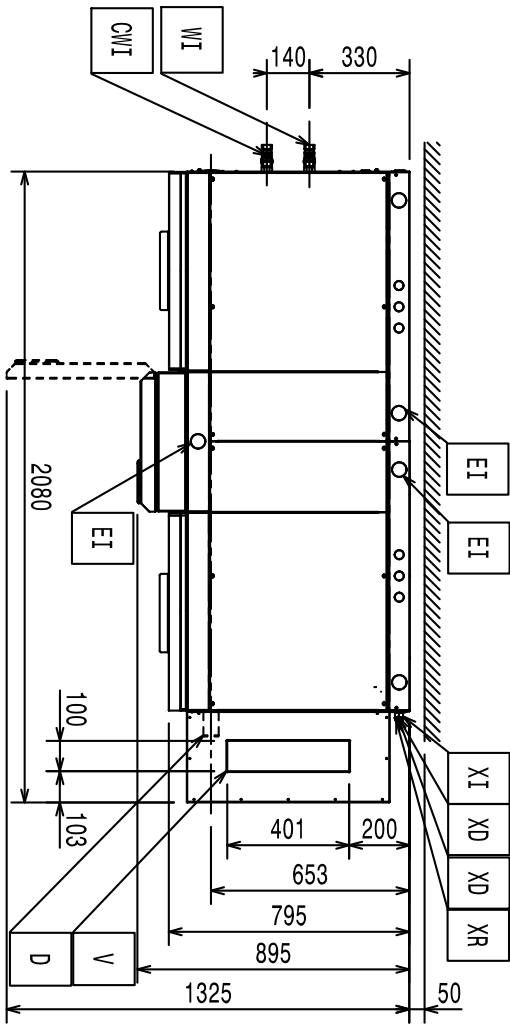

Type ref. MREE/MREEW..

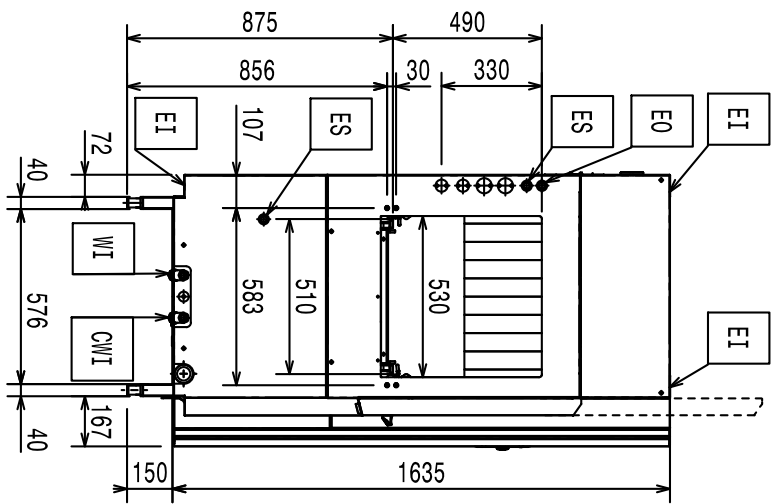
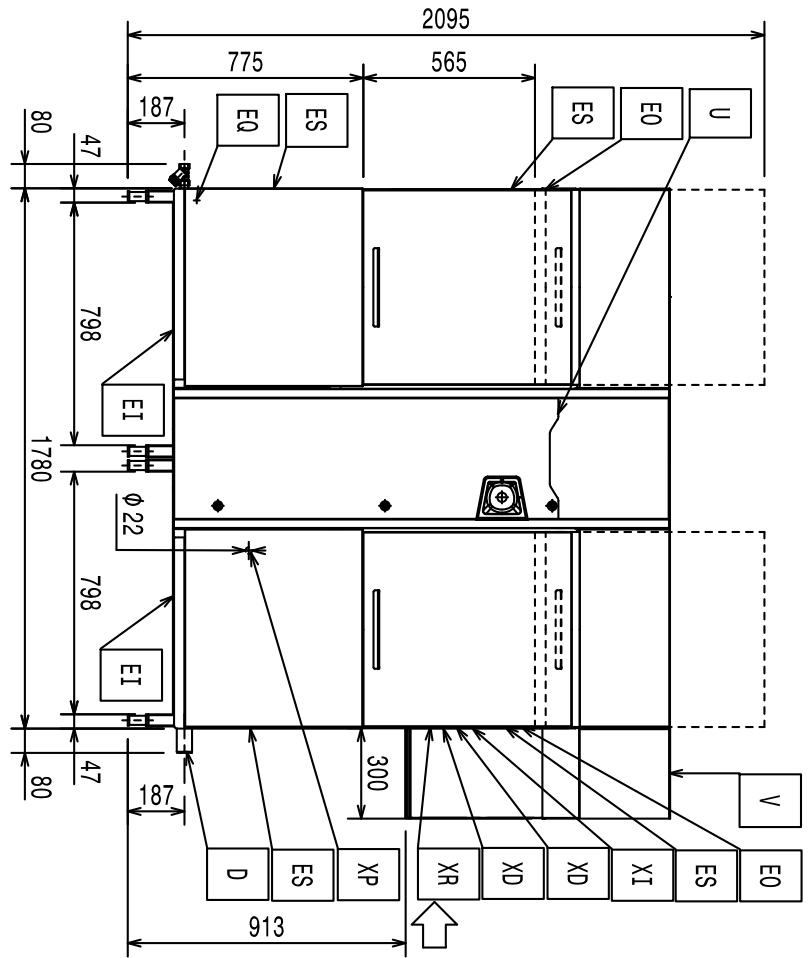

Installation diagram
150 racks/hour left to right

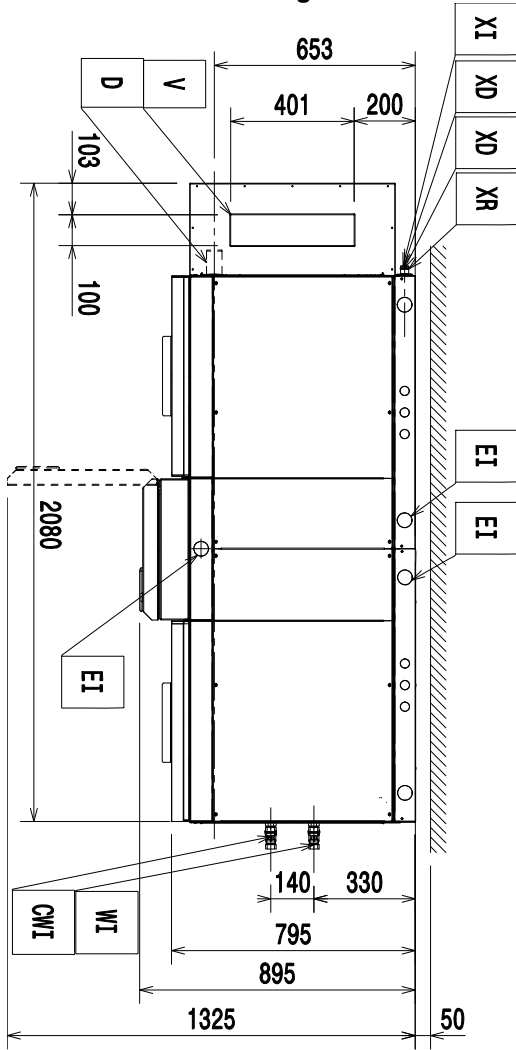

Type ref. MREE/MREEW..

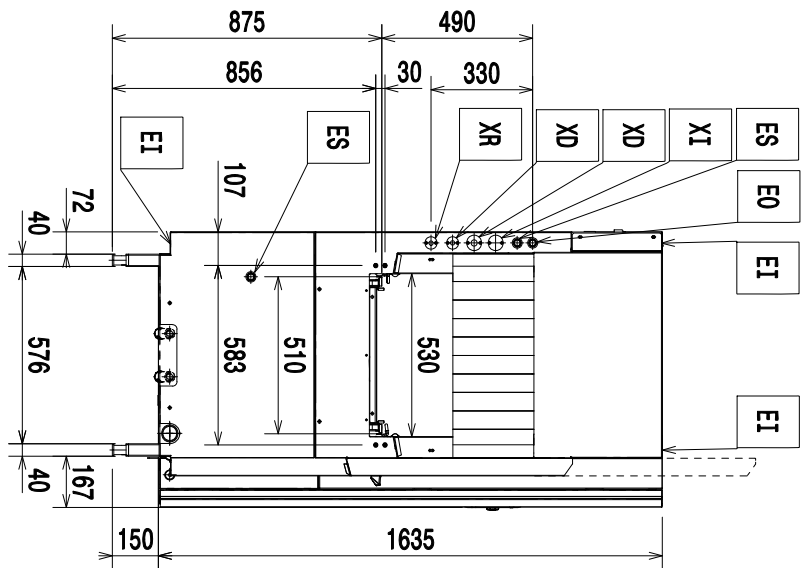
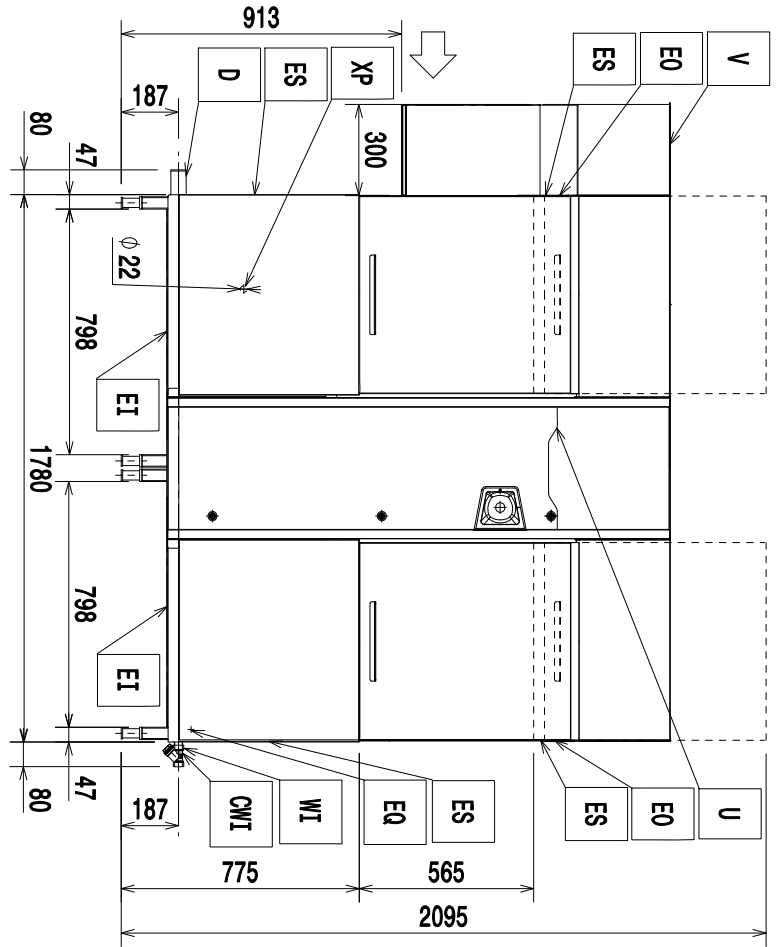

Installation diagram
200 racks/hour right to left

Type ref. PWME.MREE/MREEW..

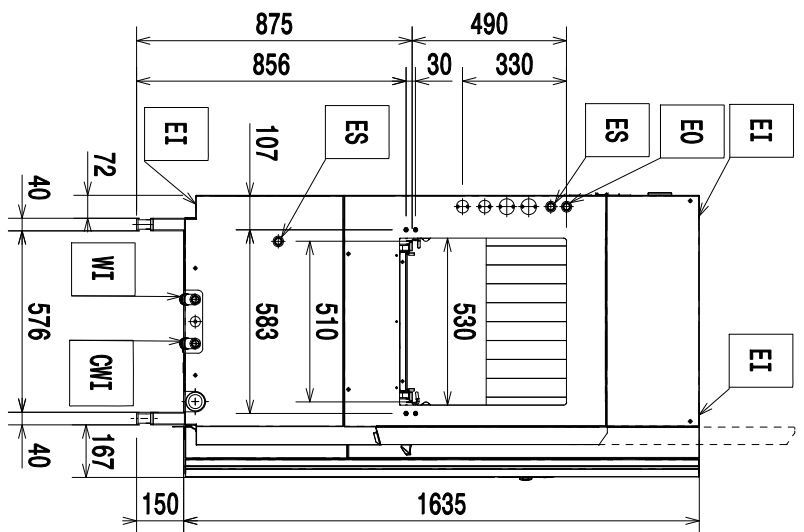
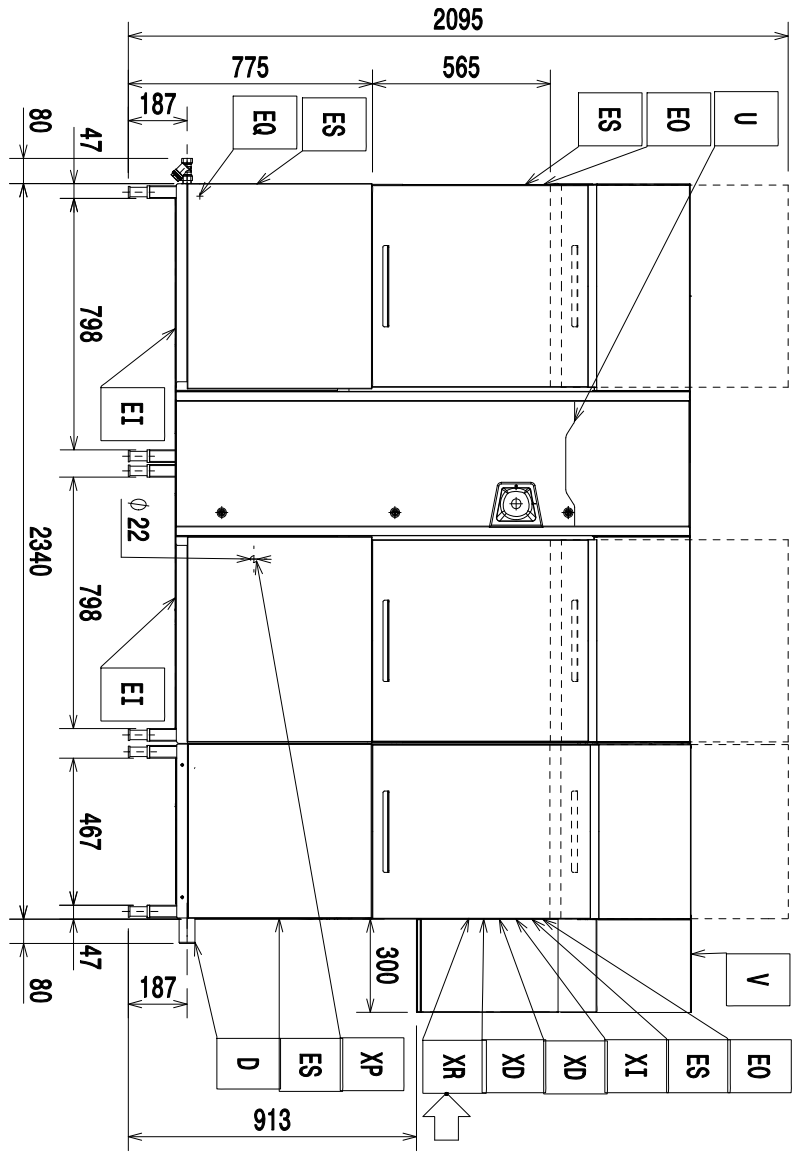
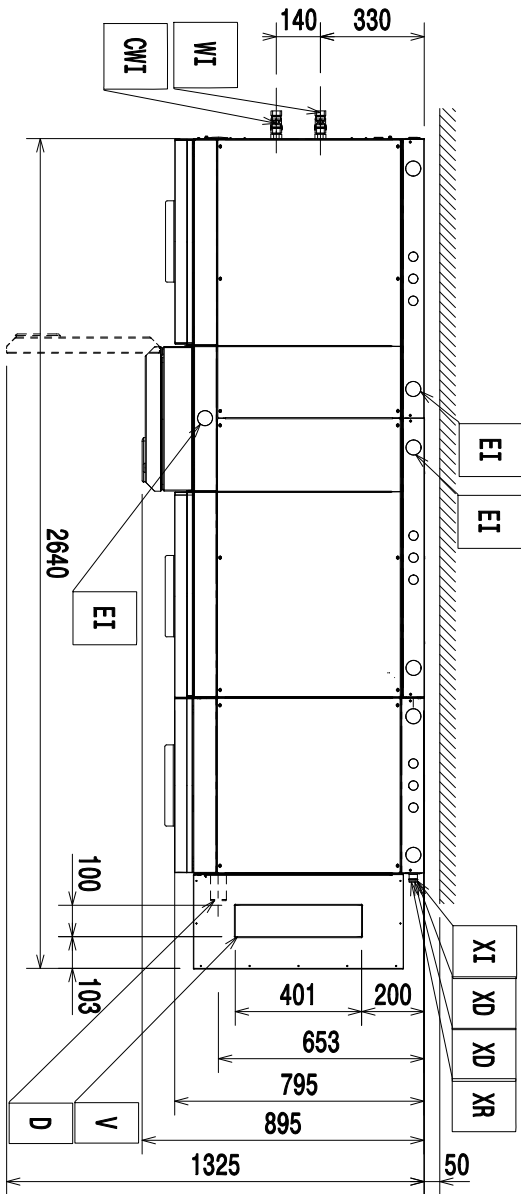

Installation diagram
200 racks/hour left to right

Type ref. PWME.MREE/MREEW..

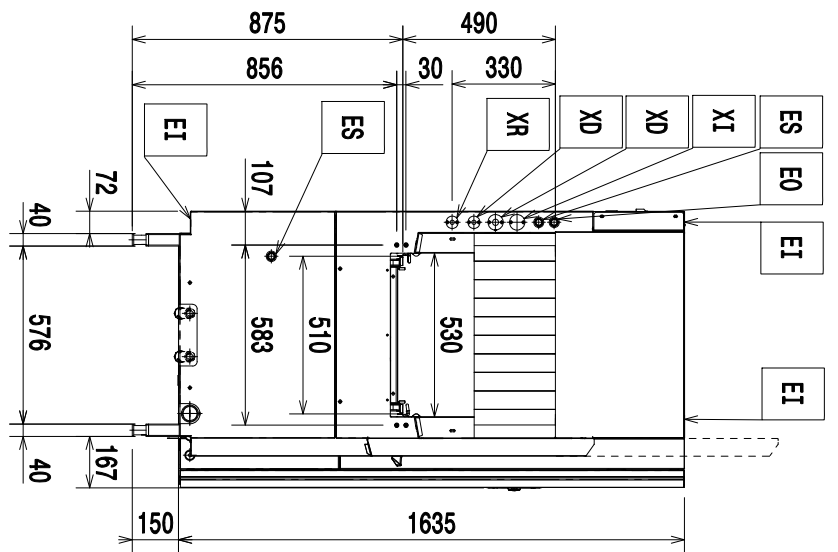
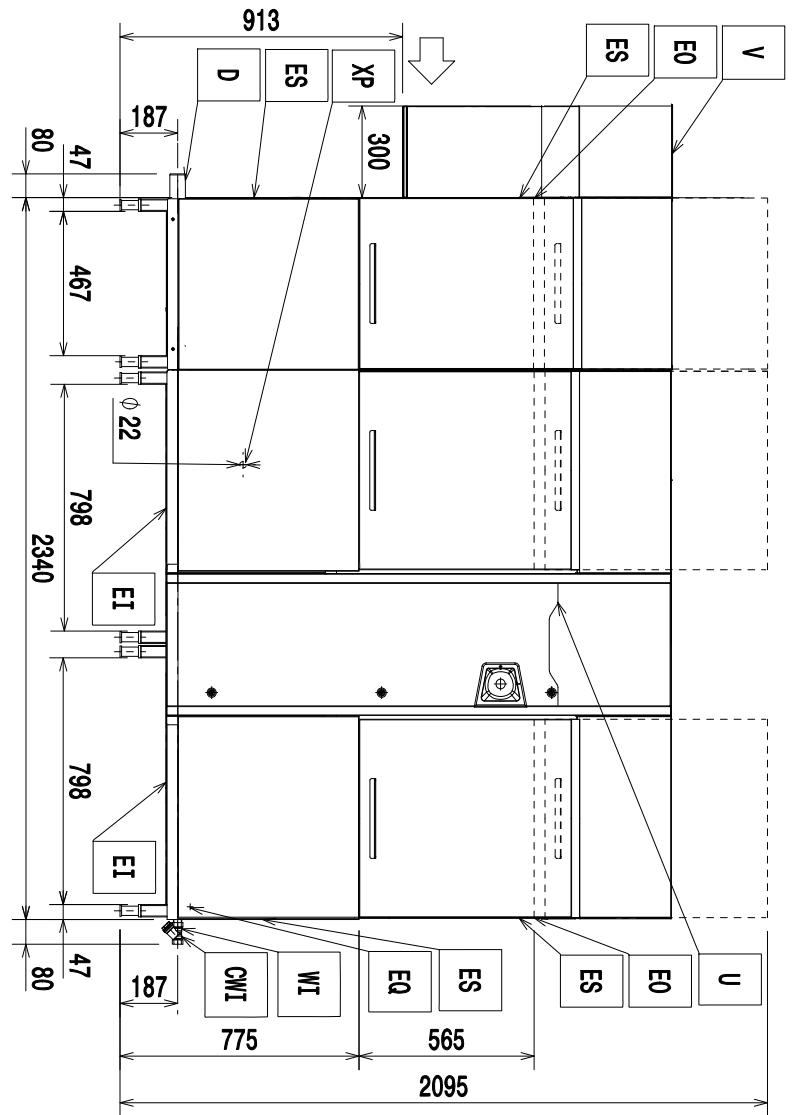
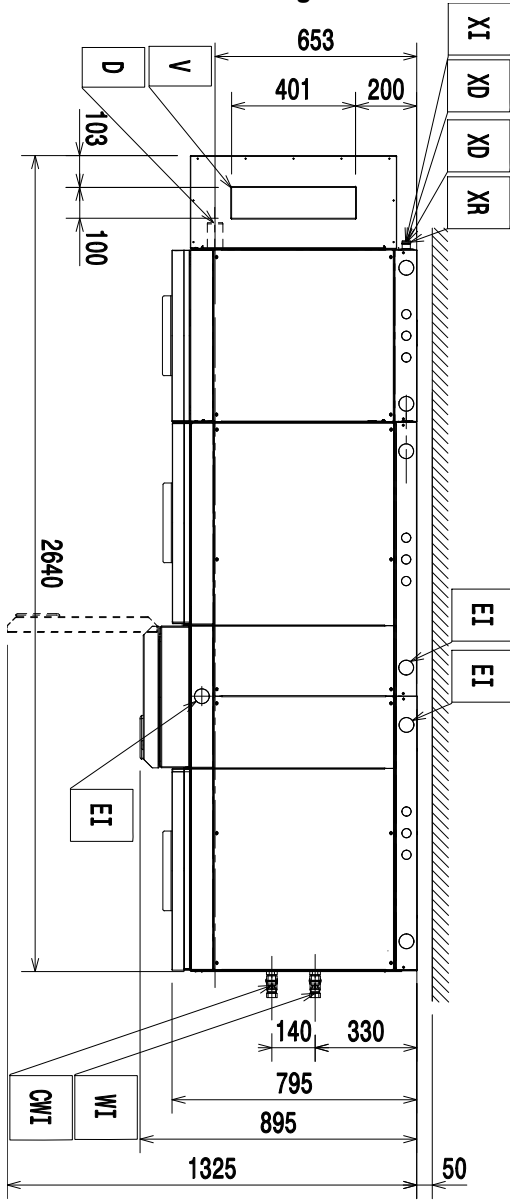

D = Drain outlet $\varnothing=50\text{mm}$ (external)
EI = Electricity inlet
EO = Electricity outlet
ES = Electrical signal IN/OUT
EQ = Equipotential screw
XD= Pipe inlet for detergent
XR= Pipe inlet for rinse-aid

XI= Pipe inlet for delime
XP= Chemicals probe/sensor
WI = Water inlet G 3/4"
CWI = Cold water inlet G 3/4"
U = USB
V = Vent(s)

Foreword



The installation, use and maintenance manual (hereinafter Manual) provides the user with information necessary for correct and safe use of the machine (or “appliance”).

The following must not be considered a long and exacting list of warnings, but rather a set of instructions suitable for improving machine performance in every respect and, above all, preventing injury to persons and animals and damage to property due to improper operating procedures.

All persons involved in machine transport, installation, commissioning, use and maintenance, repair and disassembly must consult and carefully read this manual before carrying out the various operations, in order to avoid wrong and improper actions that could compromise the machine's integrity or endanger people. Make sure to periodically inform the user regarding the safety regulations. It is also important to instruct and update personnel authorised to operate on the machine, regarding its use and maintenance.

The manual must be available to operators and carefully kept in the place where the machine is used, so that it is always at hand for consultation in case of doubts or whenever required.

If, after reading this manual, there are still doubts regarding machine use, do not hesitate to contact the Manufacturer or the authorised Service Centre to receive prompt and precise assistance for better operation and maximum efficiency of the machine. During all stages of machine use, always respect the current regulations on safety, work hygiene and environmental protection. It is the user's responsibility to make sure the machine is started and operated only in optimum conditions of safety for people, animals and property.



IMPORTANT

- The manufacturer declines any liability for operations carried out on the appliance without respecting the instructions given in this manual.
- The manufacturer reserves the right to modify the appliances presented in this publication without notice.
- No part of this manual may be reproduced.
- This manual is available in digital format by:
 - contacting the dealer or reference customer care;
 - downloading the latest and up to date manual on the web site;
- The manual must always be kept in an easily accessed place near the machine. Machine operators and maintenance personnel must be able to easily find and consult it at any time.

Contents

A	SAFETY INFORMATION	10
A.1	General information	10
A.2	General safety	10
A.3	Personal protection equipment	11
A.4	Transport, handling and storage	11
A.5	Installation and assembly	12
A.6	Water connection	12
A.7	Electrical connection	12
A.8	Service	13
A.9	Disposal of packing	13
A.10	Machine disposal	13
B	GENERAL INFORMATION	13
B.1	Introduction	13
B.2	Definitions	13
B.3	Machine and manufacturer's identification data	14
B.4	Additional indications	14
B.4.1	How to interpret the factory description	14
B.5	Responsibility	15
B.6	Copyright	15
B.7	Keeping the manual	15
B.8	Recipients of the manual	15
C	TECHNICAL DATA	15
C.1	Main technical characteristics	15
C.2	Type reference	16
C.3	Characteristics of power supply	16
D	TRANSPORT, HANDLING AND STORAGE	16
D.1	Introduction	16
D.2	Transport: Instructions for the carrier	16
D.3	Handling	16
D.3.1	Procedures for handling operations	16
D.3.2	Shifting	17
D.3.3	Placing the load	17
D.4	Storage	17
D.5	Unpacking	17
E	INSTALLATION AND ASSEMBLY	17
E.1	Introduction	17
E.2	Customer responsibilities	17
E.3	Machine space limits	17
E.4	Extraction hood	17
E.4.1	For models with "ESD" device	17
E.4.2	For models with "Heat Pump" device	18
E.5	Positioning	18
E.6	Disposal of packing	18
E.7	Plumbing connections	18
E.8	Constructional modifications	19
E.9	Installation of rack handling systems	19
E.10	Arrangement for mechanical connection (only for Electrolux rack handling system non motor operated)	19
E.11	Arrangement for electrical connection (only for Electrolux rack handling system motor operated)	20
E.12	Installation of the end limit switch	20
E.12.1	Prearrangement for electrical connection	21
E.13	Positioning of emergency switches	21
E.13.1	Electrical connection	21
E.14	Exhaust fan electrical connection	21
E.15	Installation of detergent/rinse aid dispensers	22
E.15.1	Rinse aid dispenser	22
E.15.2	Liquid detergent dispenser	22
E.15.3	Solid detergent dispenser	22
E.15.4	Delime hose connection	23
E.16	Dispensers electrical connection	23
E.16.1	Rinse aid dispenser	23
E.16.2	Liquid detergent dispenser	23
E.16.3	Solid detergent dispenser	23
E.17	Electrical connections	23
E.18	Fitting curtains	24
F	CONTROL PANEL DESCRIPTION	25
F.1	Control panel overview	25
F.2	Touch screen description	25
G	COMMISSIONING	25
G.1	Preliminary checks, adjustments and operational tests	25
G.2	Electrical and plumbing connection	26
G.3	Positioning and fitting of the tank components	26

G.4	Positioning and fitting of the washing and rinse arms	26
G.5	Positioning and fitting of the curtains	27
G.6	First starting	27
H	BASIC MACHINE SETUP	27
H.1	Enter into service menu	27
H.2	User Interface settings menu.....	28
H.3	Installation settings menu	29

A SAFETY INFORMATION

A.1 General information

To ensure safe use of the machine and a proper understanding of the manual it is necessary to be familiar with the terms and typographical conventions used in the documentation. The following symbols are used in the manual to indicate and identify the various types of hazards:



WARNING

Danger for the health and safety of operators.



WARNING

Danger of electrocution - dangerous voltage.



CAUTION

Risk of damage to the machine or the product.



IMPORTANT

Important instructions or information on the product



Equipotentiality



Read the instructions before using the appliance







Clarifications and explanations

A.2 General safety

- The machine must not be used by people (including children) with limited physical, sensory or mental abilities or without experience and knowledge of it, unless instructed in its use and supervised by those responsible for their safety.
 - Do not let children play with the machine.
 - Keep all packaging and detergents away from children.
 - Cleaning and user maintenance shall not be made by children without supervision.
- For suitable personal protection equipment, refer to chapter “A.3 *Personal protection equipment*”.
- Several illustrations in the manual show the machine, or parts of it, without guards or with guards removed. This is purely for explanatory purposes. Do not install the machine without the guards or with the protection devices deactivated.
- Do not remove, tamper with or make illegible the safety, danger and instruction signs and labels on the machine.
- Do not remove or tamper with the machine’s safety devices.
- Before carrying out any machine installation, always consult the installation manual, which gives the correct procedures and contains important information on safety.
- Unauthorized personnel must not enter the work area.
- Remove any flammable products or items from the work area.
- Machine positioning, installation and disassembly must be carried out by the specialised personnel in conformity with the current safety regulations, regarding the equipment used and the operating procedures.

A.3 Personal protection equipment

Summary table of the Personal Protection Equipment (PPE) to be used during the various stages of the machine's service life.

Stage	Protective garments 	Safety footwear 	Gloves 	Glasses 	Safety helmet 
Transport	—	●	○	—	○
Handling	●	●	○	—	—
Unpacking	○	●	○	—	—
Installation	○	●	● ¹	—	—
Normal use	●	●	● ²	○	—
Adjustments	○	●	—	—	—
Routine cleaning	○	●	● ¹⁻³	○	—
Extraordinary cleaning	○	●	● ¹⁻³	○	—
Maintenance	○	●	○	—	—
Dismantling	○	●	○	○	—
Scrapping	○	●	○	○	—
Key:					
●	PPE REQUIRED				
○	PPE AVAILABLE OR TO BE USED IF NECESSARY				
—	PPE NOT REQUIRED				

1. During these operations, gloves must be cut-resistant. Failure to use the personal protection equipment by operators, specialized personnel or users can involve exposure to damage to health (depending on the model).
2. During these operations, gloves must be heatproof and suitable for contact with water and the substances used (refer to the safety data sheet of the substances used for the information regarding the required PPE). Failure to use the personal protection equipment by operators, specialised personnel or users can involve exposure to chemical risk and cause possible damage to health (depending on the model).
3. During these operations, gloves must be suitable for contact with chemical substances used (refer to the safety data sheet of the substances used for information regarding the required PPE). Failure to use the personal protection equipment by operators, specialized personnel or users can involve exposure to chemical risk and cause possible damage to health (depending on the model).

A.4 Transport, handling and storage

- Due to their size, the machines cannot be stacked on top of each other during transport, handling and storage; this eliminates any risks of loads tipping over due to stacking.
- Do not stand under suspended loads during loading or unloading operations. Unauthorized personnel must not enter the work area.
- The weight of the appliance alone is not sufficient to keep it steady.
- For machine lifting and anchoring, do not use movable or weak parts such as: casings, electrical raceways, pneumatic parts, etc.
- Do not push or pull the machine to move it, as it may tip over. Use proper tool to lift the machine.

- Machine transport, handling and storage personnel must be adequately instructed and trained regarding the use of lifting systems and personal protection equipment suitable for the type of operation carried out.

A.5 Installation and assembly

- Follow the installation instruction supplied with the machine.
- Do not install a damaged machine. Any missing or faulty parts must be replaced with original parts.
- Do not make any modifications to the parts supplied with the machine.
- Disconnect the machine from the power supply before carrying out any installation procedure. Connect the machine to the power supply only at the end of the installation.
- The machine is not suitable for installation outdoors and/or in places exposed to atmospheric agents (rain, direct sunlight, freeze, humid and dusty location, etc.).
- Do not install the machine over 2000 meters above sea level.
- Make sure that the floor where you install the machine is flat, stable, heat resistant and clean.
- Use a ladder with suitable protection for work on machines with high accessibility.

A.6 Water connection

- The plumbing connections must be carried out by a specialised personnel.
- The machine is to be connected to the water mains using the new supplied hose-sets. Do not use old hose sets.
- Always use a new set of joints if you remove and re-install the water inlet pipe to the machine.
- Before connection to new pipes, pipes not used for a long time, where repair work has been carried out or new devices fitted (water meters, etc.), let the water flow until it is clean and clear.
- The operating water pressure (minimum and maximum) must be between:
 - 1.5 bar [150 kPa] and 6 bar [600 kPa] for models with ESD;
- Make sure that there are no visible water leaks during and after the first use of the machine.
- Install an approved dual check valve upstream according to the regulation of the installation country.

A.7 Electrical connection

- Work on the electrical systems must only be carried out by a specialised personnel.
- Make sure that the electrical information on the rating plate agrees with the power supply.
- Make sure to install the machine in accordance with the safety regulations and local laws of the country where used.
- If the power cable is damaged it must be replaced by the Customer Care Service or in any case by specialised personnel, in order to prevent any risk.
- The machine must be correctly earthed. The manufacturer is not responsible for the consequences of an inadequate earthing system.
- If present, connected the machine to the equipotential protection circuit ∇ .
- To protect the power supply of the machine against short circuits and/or overloads, install a thermal fuse or a suitable automatic thermal magnetic circuit breaker, ADS (Automatic Disconnection of Supply).
- To protect the power supply of the machine against current leakages, install a high-sensitivity manual reset RCD (Residual Current Device), suitable for overvoltage category III.
- For protection against indirect contacts (depending on the type of supply provided for and connection of earths to the equipotential protection circuit ∇) refer to point 6.3.3 of EN 60204-1 (IEC 60204-1) with the use of protection devices that ensure automatic cut-

off of the supply in case of isolation fault in the TN or TT systems or, for IT systems, the use of isolation controllers or differential current protection devices to activate automatic power disconnection (an isolation controller must be provided for indicating a possible first earth fault of a live part, unless a protection device is supplied for switching off the power in case of a such a fault. This device must activate an acoustic and/or visual signal which must continue for the entire duration of the fault). For example: in a TT system, a residual current device with cut-in current (e.g. 30 mA) coordinated with the earthing system of the building where the machine is located must be installed ahead of the supply.

- Make sure to install an emergency switch at the infeed and outfeed of the rack-type dishwasher. For all additional modules installed later, move the emergency switch at the ends of the equipment.
- For all the additional modules installed later, make sure that the power cable supply is properly sized.

A.8 Service

- Only original spare parts can ensure the safety standards of the appliance.

A.9 Disposal of packing

- Dispose of each packaging items respecting the current regulation in the country of installation.

A.10 Machine disposal

- Work on the electrical equipment must only be carried out by a specialised personnel, with the power supply disconnected.
- Dismantling operations must be carried out by specialised personnel.
- Make the appliance unusable by removing the power cable and any compartment closing devices, to prevent the possibility of someone becoming trapped inside.
- Refer to “A.3 Personal protection equipment” for suitable personal protection equipment.
- When scrapping the machine, the “CE” marking, this manual and other documents concerning the appliance must be destroyed.



IMPORTANT

Save these instructions carefully for further consultation by the various operators.

B GENERAL INFORMATION

B.1 Introduction

Given below is some information regarding the intended use of this appliance, its testing, and a description of the symbols used (that identifies the type of warning), the definitions of terms used in the manual and useful information for the appliance user.

B.2 Definitions

Listed below are the definitions of the main terms used in the manual. It is advisable to read them carefully before use.

Operator	machine installation, adjustment, use, maintenance, cleaning, repair and transport personnel.
Manufacturer	Electrolux Professional SpA or any other service centre authorised by Electrolux Professional SpA.
Operator for normal machine use	an operator who has been informed and trained regarding the tasks and hazards involved in normal machine use.

Customer Care service or specialised technician	an operator instructed/trained by the Manufacturer and who, based on his professional and specific training, experience and knowledge of the accident-prevention regulations, is able to appraise the operations to be carried out on the machine and recognise and prevent any risks. His professionalism covers the mechanical, electrotechnical and electronics fields.
Danger	source of possible injury or harm to health.
Hazardous situation	any situation where an operator is exposed to one or more hazards.
Risk	a combination of probabilities and risks of injury or harm to health in a hazardous situation.
Protection devices	safety measures consisting of the use of specific technical means (guards and safety devices) for protecting operators against risks.

Guard	an element of a machine used in a specific way to provide protection by means of a physical barrier.
Safety device	a device (other than a guard) that eliminates or reduces the risk; it can be used alone or in combination with a guard.
Customer	the person who purchased the machine and/or who manages and uses it (e.g. company, entrepreneur, firm).
Emergency stop device	a group of components intended for the emergency stop function; the device is activated with a single action and prevents or reduces damage to persons/machines/property/animals.
Electrocution	an accidental discharge of electric current on a human body.

B.3 Machine and manufacturer's identification data

An example of the marking or data plate on the machine is given below:

ELX	Made in EU	2017
F.Mod. _____	Comm.Model _____	
PNC _____	Ser.Nr. _____	
EL _____ V	Hz _____	kW _____
Type ref. _____		
CE	IPX5	
Electrolux Professional spa - Viale Treviso, 15 - 33170 Pordenone (Italy)		

The data plate gives the product identification and technical data. The meaning of the various information given on it is listed below:

F.Mod.	factory description of product
Comm.Model	commercial description
PNC	production number code
Ser.Nr.	serial number
V	power supply voltage
Hz	power supply frequency
kW	max. power input
Type ref.	list of acronyms used to identify the type of machine, uniquely
CE	CE marking
IPX5	dust and water protection rating
Electrolux Professional SpA Viale Treviso 15 33170 Pordenone Italy	manufacturer

The data plate is located on the front panel of the equipment.

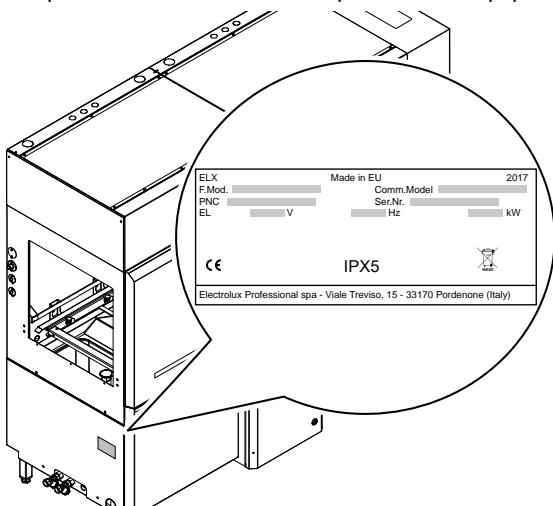

Fig. 1 Data plate position (machine right)

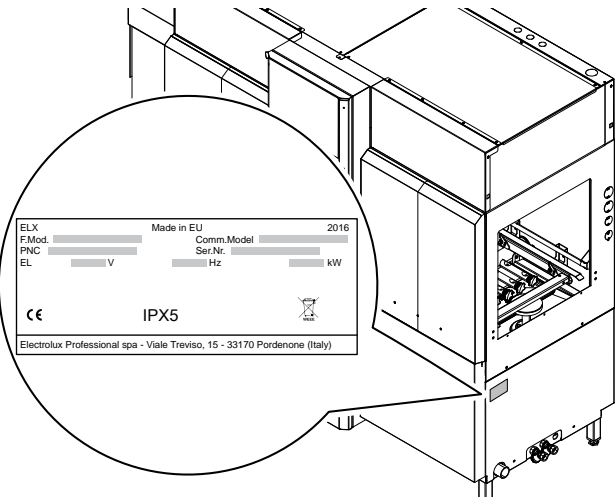

Fig. 2 Data plate position (machine left)



IMPORTANT

When installing the machine, make sure the electrical connection is carried out in compliance with that specified on the data plate.



NOTE!

Refer to the data given on the machine's data plate for relations with the Manufacturer (e.g. when ordering spare parts, etc.).

B.4 Additional indications

The drawings and diagrams given in the manual are not in scale. They supplement the written information with an outline, but are not intended to be a detailed representation of the machine supplied.

The numerical values given on the machine installation diagrams refer to measurements in millimeters and/or inches.

Conventionally, the machine are depicted with the rack feed side on the right ("R"); machine with left rack feed ("L") are depicted only if necessary, in which case the side will be expressly specified.

Due to its size, the machine is sometimes shown schematically divided into its functional modules in order to provide a complete view.

B.4.1 How to interpret the factory description

The factory description on the data plate has the following meaning:

(1)	(2)	(3)	(4)	(5)	(6)	(7)	(8)
E	MR	15	N	E	R	E	
Z	MR	20	L	E	L	E	

	Description	Possible variables
(1)	Brand	E=Electrolux, Z=Zanussi, N= To brand
(2)	Machine Type	MR = multi rinse
(3)	Racks/hour	150 - 200
(4)	Dryer	N=None; M=22"; L=35"
(5)	Supply	E = Electric
(6)	Direction	R = from right to left L = from left to right
(7)	Functional level	E = Energy Saving Device (ESD)
(8)	Other functions	P = prewash

B.5 Responsibility

The Manufacturer declines any liability for damage and malfunctioning caused by:

- non-compliance with the instructions contained in this manual;
- repairs not carried out in a workmanlike fashion, and replacements with parts different from those specified in the spare parts catalogue (the fitting and use of non-original spare parts and accessories can negatively affect machine operation and invalidates the original manufacturer warranty);
- operations carried out by non-specialised personnel;
- unauthorized modifications or operations;
- missing, lack or inadequate maintenance;
- improper machine use;
- unforeseeable extraordinary events;
- use of the machine by uninformed and / or untrained personnel;
- non-application of the current provisions in the country of use, concerning safety, hygiene and health in the workplace.

The Manufacturer declines any liability for damage caused by arbitrary modifications and conversions carried out by the user or the Customer.

The employer, workplace manager or service technician are responsible for identifying and choosing adequate and suitable personal protection equipment to be worn by operators, in compliance with regulations in force in the country of use.

The Manufacturer declines any liability for inaccuracies contained in the manual, if due to printing or translation errors.

Any supplements to the installation, use and maintenance manual the Customer receives from the Manufacturer will form an integral part of the manual and therefore must be kept together with it.

B.6 Copyright

This manual is intended solely for consultation by the operator and can only be given to third parties with the permission of Electrolux Professional SpA.

B.7 Keeping the manual

The manual must be carefully kept for the entire life of the machine, until scrapping. The manual must stay with the machine in case of transfer, sale, hire, granting of use or leasing.

B.8 Recipients of the manual

This manual is intended for:

- the carrier and handling personnel;
- installation and commissioning personnel;
- specialised personnel - Customer Care service (see service manual).

C TECHNICAL DATA

C.1 Main technical characteristics

Common

Power supply voltage	V	220 - 240 3
Frequency	Hz	50
Power cable	Type	H07RN-F
	N° x mm ²	4x50
Main switch	A	125A 3P+N
Supply water pressure	bar [kPa]	1.5 bar [150 kPa]...6 bar [600 kPa]
Hot water supply temp.	°C	5-65 [50] ¹
Cold water supply temp.	°C	5-30 [15]
Concentration of chlorides in water	ppm	<20
Supply water hardness	°f/°d/°e	14/8/10
Electric conductivity of water	µS/cm	<400
Protection rating		IPX5
Nr. wash speeds		3

1. Hot water temperature recommended

Machine

Model		150 racks/hour	200 racks/hour
Capacity wash at speed 3	racks/h	150	200
Water consumption	l/h	60	80
Max. power absorbed	kW	30.75	32.9
Max. current absorbed	A	82.38	82.38
Legal noise level Leq	dB(A)	LpA:58dB - KpA:1.5dB ¹	LpA:58dB - KpA:1.5dB ¹

1. The noise emission values have been obtained according to EN ISO 11204.

C.2 Type reference

Legend

Prewash module		Machine module		Dryer module	
PW	Prewash	MR	Multi Rinse	D	Dryer
M	Medium (22")			M	Medium (22")
				L	Large (35")
				C	Corner
E	Electric	E	Electric	E	Electric
		E	Energy Saving Device (ESD)		
W	WRAS & Watermark approval		WRAS & Watermark approval		

Machine with Energy Saving Device (ESD)

Model	PW module	Machine module	DR Module	Max POWER (KW)	Max Current (A)
150 racks/hour		MREE MREEW ¹		30.75	82.38
			DME	35.05	94
			DLE	35.02	95.25
			DCE	35.02	95.25
200 racks/hour	PWME	MREE MREEW ¹		32.9	82.38
			DME	37.2	96.15
			DLE	39.32	97.40
			DCE	39.32	97.40

1. Suitable for UK and Australia



CAUTION

For all the additional modules installed later, make sure that the power cable supply is properly sized.

C.3 Characteristics of power supply

The AC power supply to the machine must meet the following conditions:

- max. voltage variation $\pm 6\%$
- max. frequency variation $\pm 1\%$ continuous $\pm 2\%$ for a short period.

Harmonic distortion, unbalanced three-phase supply voltage, voltage pulses, interruption, dips and the other electric characteristics must respect the provisions of point 4.3.2 of Standard EN 60204-1 (IEC 60204-1).

D TRANSPORT, HANDLING AND STORAGE



WARNING

Refer to "Safety Information".

D.1 Introduction

Transport (i. e. transfer of the machine from one place to another) and handling (i. e. transfer inside workplaces) must occur with the use of special and adequate means.



CAUTION

The machine must only be transported, handled and stored by specialised personnel, who must have:

- specific technical training and experience in the use of lifting systems;
- knowledge of the safety regulations and applicable laws in the relevant sectors;
- knowledge of the general safety rules;
- personal protection equipment suitable for the type of operation carried out;
- the ability to recognize and avoid any possible hazard.

D.2 Transport: Instructions for the carrier



IMPORTANT

The transported load can shift:

- when braking;
- when accelerating;
- in corners;
- on rough roads.

D.3 Handling

Arrange a suitable area with flat floor for machine unloading and storage operations.

D.3.1 Procedures for handling operations

Before lifting:

- send all operators to a safe position and prevent persons from entering the handling area;
- make sure the load is stable;
- make sure no material can fall during lifting. Manoeuvre vertically in order to avoid impacts;
- handle the machine, keeping it at minimum height from the ground.

For correct and safe lifting operations:

- use the type of equipment most suitable for characteristics and capacity (e.g. electric pallet truck or lift truck);
- cover sharp edges;
- check the forks and lifting procedures according to the instructions given on the packing.

D.3.2 Shifting

The operator must:

- have a general view of the path to be followed;
- stop the manoeuvre in case of hazardous situations.

D.3.3 Placing the load

- Before placing the load, make sure the way is free and that the floor is flat and can take the load.
- Remove the appliance from the wooden pallet, move it to one side, then slide it onto the floor.

D.4 Storage

The machine and/or its parts must be stored and protected from damp, in a non-aggressive place, free of vibrations and with room temperatures between -10°C [14°F] and 50°C [122°F].

The place where the machine is stored must have a flat support surface to avoid deforming the machine or damage to the support feet.



CAUTION

Do not make modifications to the parts supplied with the appliance. Any missing or faulty parts must be replaced with original parts.

D.5 Unpacking



IMPORTANT

Immediately check for any damage caused during transport. Inspect the packaging before and after unloading.

1. Remove the packaging.
Take care when unpacking and handling of the appliance to not cause any shocks on itself.
2. Keep all the documentation contained in the packaging.

Note

- The forwarder is responsible for the goods during transport and delivery.
- Make a complaint to the forwarder in case of visible or hidden damage.
- Specify any damage or shortages on the dispatch note.
- The driver must sign the dispatch note: the forwarder can reject the claim if the dispatch note is not signed (the forwarder can provide the necessary form).
- For hidden damage or shortages becoming apparent only after unpacking, request the forwarder for inspection of the goods within and no later than 15 days after delivery.

E INSTALLATION AND ASSEMBLY



WARNING

Refer to “*Safety Information*”.

E.1 Introduction



WARNING

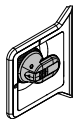

Make sure that the switch disconnector of the machine is locked in the Off position - “O”.

E.2 Customer responsibilities

The Customer must provide for the following:

- installation of an adequate electrical power supply ahead of the appliance, according to the equipment’s technical specifications (C *TECHNICAL DATA* and C.3 *Characteristics of power supply*);
- the equipotential connection ∇ of the workplace electrical system to the metal structure of the machine by means of a copper cable of adequate section (see position “EQ” in *Installation diagram*);
- adducting for the electrical connection between the workplace electric panel and the equipment;
- the water supply and drain connections and other connections as indicated in C *TECHNICAL DATA* and in the paragraph E.7 *Plumbing connections*;

E.3 Machine space limits

- A suitable space must be left around the machine (for operations, maintenance, for a correct air exchange, etc.).
- This space must be increased in case of use and/or transfer of other equipment and/or means or if exit routes are necessary inside the workplace.



CAUTION

Install the machine at a distance of not less than 50 mm from the wall so as not to affect correct ventilation of internal components.

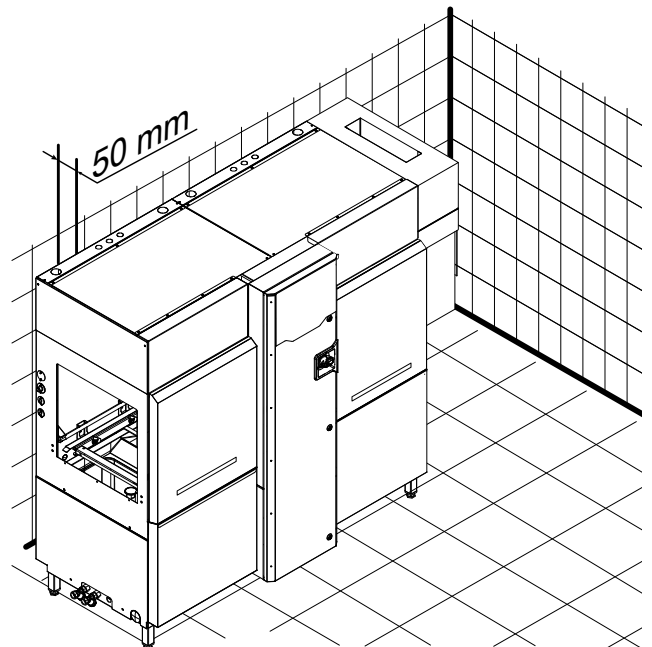

E.4 Extraction hood

E.4.1 For models with “ESD” device

Make sure to position the possible extraction hood at a distance of not less than 400 mm from the machine so as not to compromise machine operation.

The extractor hood is installed to remove the steam emitted by the machine. The hood air delivery must be calculated taking into account the machine model, the type of installation and the work environment where installed.

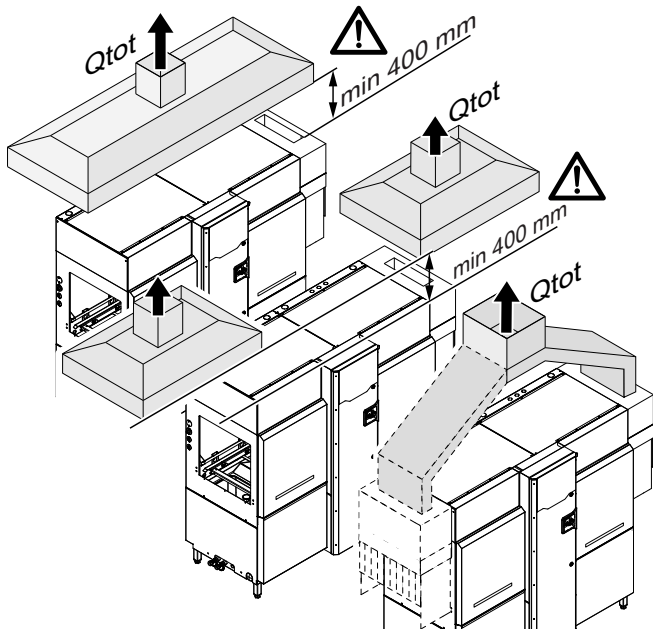

Model	Qtot (VDI2052)
...MR15....E	1500 m ³ /h
...MR20....E	1700 m ³ /h

E.4.2 For models with “Heat Pump” device

For all the ventless models, it is not necessary to install any extraction hood as indicated in the technical data sheet below.

- According to “VDI2052” these models do not require any dedicated ventilation hood. General ventilation for the room should be still provided in accordance with “UNI ISO EN 7730” norm, “VDI2052” guideline and “DW/172 UK” or local regulation.

E.5 Positioning



NOTE!
Make sure that the room temperature where you install the machine must be at least 18°C [64.5°F].

The machine must be taken to the place of installation and the packing base removed only when being installed.

Arranging the machine:

- Position the machine in the required place.
- Adjust the equipment by turning the special adjustable feet. To facilitate the perfect drainage of the water during the drain cycle, adjust the machine with a minimum inclination of 3° on the drain side.

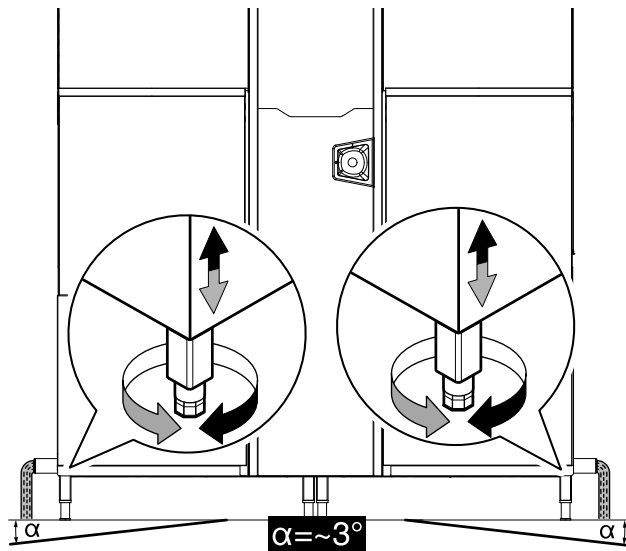

- Adjust the machine crosswise with a minimum inclination of 3° in order to facilitate the drainage of the dirty water from the tanks.

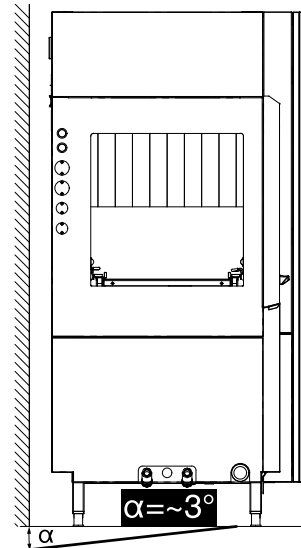

- Carefully remove the protective film from the outer panels without tearing it, to avoid leaving traces of glue.

E.6 Disposal of packing

The packing must be disposed of in compliance with the current regulations in the country where the appliance is used. All the packing materials are environmentally friendly.

They can be safely kept, recycled or burned in an appropriate waste incineration plant. Recyclable plastic parts are marked as follows:

	Polyethylene
	<ul style="list-style-type: none"> • Outer wrapping • Instructions bag
	Polypropylene
	<ul style="list-style-type: none"> • Straps
	Polystyrene foam
	<ul style="list-style-type: none"> • Corner protectors

The parts in wood and cardboard can be disposed of, respecting the current regulations in the country where the machine is used.

E.7 Plumbing connections



IMPORTANT

Watermark labelled appliances must be installed in accordance with AS/NZS 3500.1 and drainage to be in accordance with 3500.2.

Install the machine water inlets and drain pipes according to the plumbing circuit and installation diagrams.

A booster pump must be installed ahead of the machine, if:

- the water pressure is less than 1.5 bar [150 kPa] for “ESD” models;
- If the pressure is more than 6 bar [600 kPa], a pressure reducing valve must be installed on the inlet pipe. The supply water temperature is related to the machine setup.

Water connection ISO 228/1 DN 20 (G3/4”)

- Cold water inlet temperature:
 - 5-30°C
- Hot water inlet temperature:
 - 5-65°C
 - The recommended hot water temperature is: 50°C

- Water inlet pressure:
 - 1.5 bar [150 kPa] - 6 bar [600 kPa] at 0,3 l/sec

Drain outlet hose connection

- Connect the drain outlet hose to the main drain pipe, fitting a trap, or place the outlet pipe over an “S” trap set into the floor.

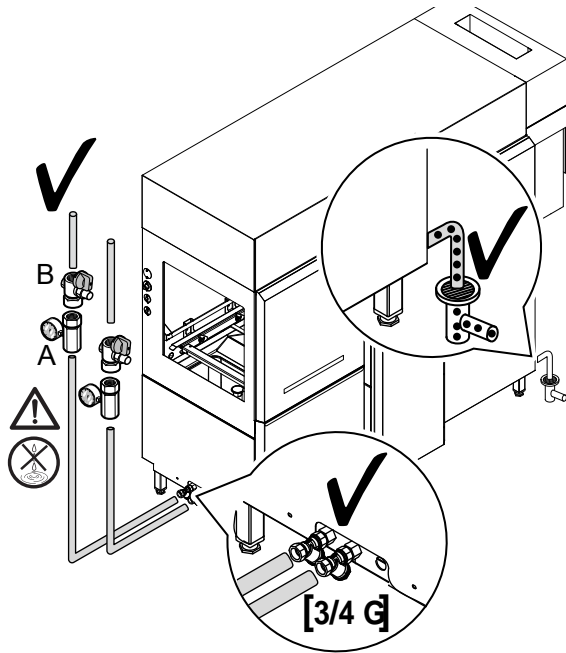

Fig. 3 Plumbing connection for left machine

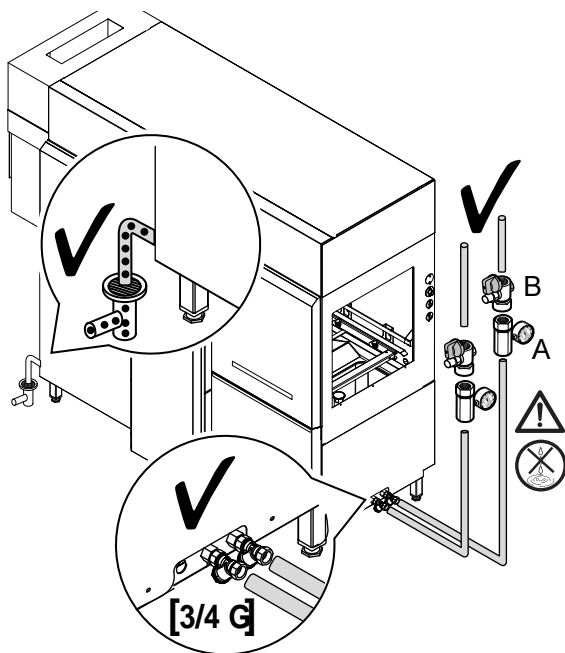

Fig. 4 Plumbing connection for right machine



CAUTION

For every connection, installing a cut-off valve “B” and a pressure gauge “A” between the machine and the mains. Pay attention to seal every component in order to avoid water leaks.



NOTE!

Connection pipes with anti-return/back flow protection and check valve and on/off valve are available as optional accessories.

To ensure efficient machine operation, install a water treatment device on the dishwasher inlet connection piping if:

- the water hardness exceeds 14°fH/8°dH/10°eH (a water softener and/or a water demineralizer);
- the water concentration of chlorides in water exceeds 20 ppm (a reverse osmosis device).

E.8 Constructional modifications

The Manufacturer provides for the possibility of connecting the rack-type dishwasher to rack handling systems included in the Electrolux Professional product catalogue, with the possibility of obtaining various configurations. The “EC” Conformity Declaration provided with the machine also envisages these configurations. The Manufacturer does not provide for the possibility of making other constructional modifications to the machine, but allows the execution of other types of combinations with systems different from those described above (in order to create a series of machines arranged and controlled in an integral way), as illustrated in this documentation. In which case it is necessary to comply with provisions of the applicable European Directives or current regulations in the country of use, and obtain the required certifications. The Manufacturer declines any liability for damage caused by arbitrary modifications and conversions carried out by the user or third parties. For requests or for further information, contact Electrolux Professional SpA - Via Treviso, 15 - 33170 Pordenone - Italy.

E.9 Installation of rack handling systems



WARNING

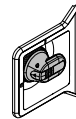

Make sure that the switch disconnector of the machine is locked in the Off position - “O”.

The arrangements for the mechanical and electrical connections provided for on the rack-type dishwasher are described below. For further details on the various types of rack handling system couplings, consult the instructions supplied with the specific handling system installed.

E.10 Arrangement for mechanical connection (only for Electrolux rack handling system non motor operated)

This arrangement is suitable for fitting non-motor-operated rack handling systems (e.g. roller-ways, tables, etc.).

1. Remove the vent(s) from the machine, if present. You can see 2 holes in the left and 2 holes in right side of the machine panels.

- Use 4 metric screws ($\varnothing=6$ mm), "B" to connect the rack handling system to the dishwasher.

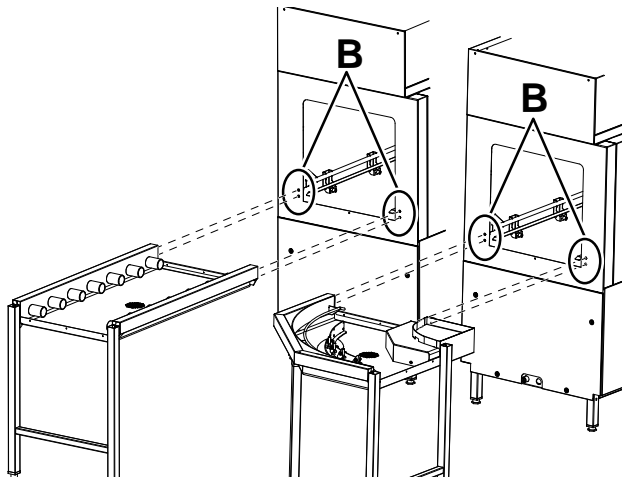

- Adjust the equipment by turning the special adjustable feet and making sure it is perfectly level.

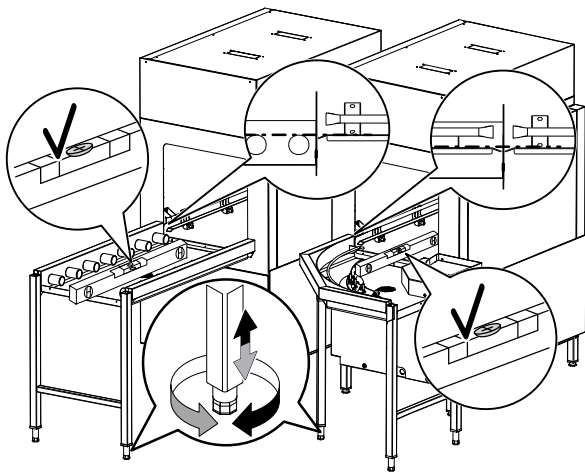

- Refer to the instruction provided with the rack handling system to complete the installation.
- Apply silicone¹ "C" between the dishwasher and the rack handling system.

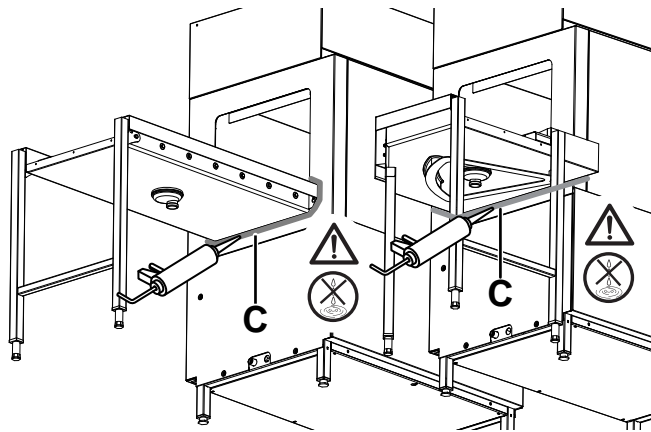
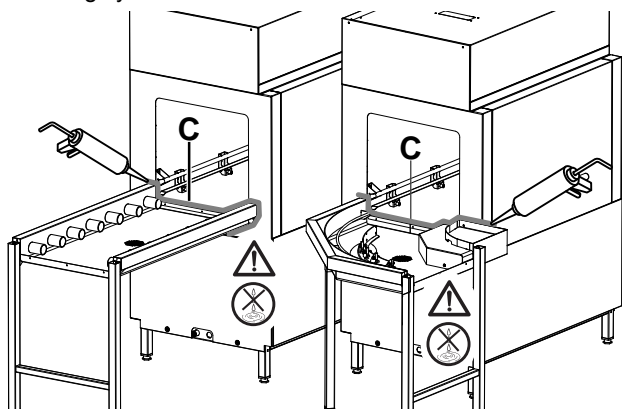

CAUTION
Make sure that there are not any water leakages.

E.11 Arrangement for electrical connection (only for Electrolux rack handling system motor operated)

This arrangement is suitable for fitting motor-operated rack handling systems (e.g. rope conveyor belts).

To install the motor-operated rack handling systems, consult the instructions provided with the Electrolux rack handling system.



CAUTION
The electrical power lines of the rack handling system are protected against short circuits as shown in the wiring diagram.

E.12 Installation of the end limit switch



IMPORTANT
Install only Electrolux End Limit Switch.

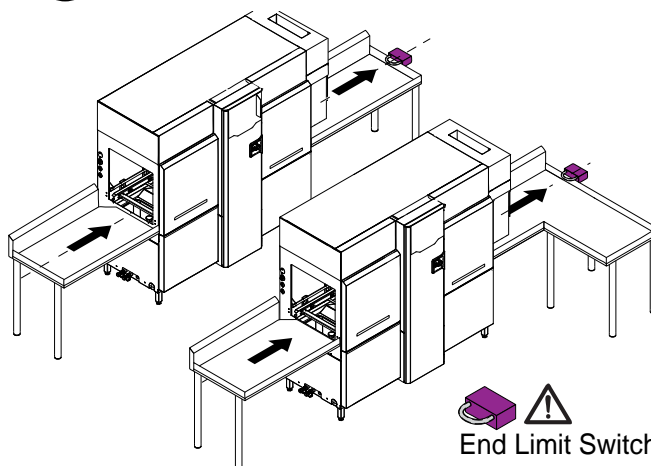

1. It is available for this purpose recommended silicone by Electrolux. You can order it with this reference code 059611.

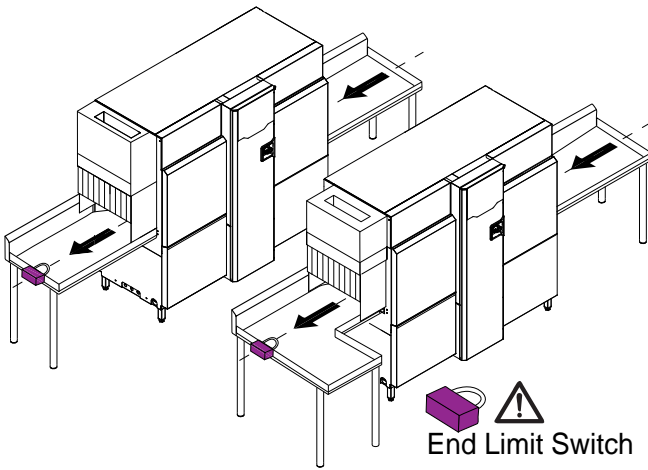

E.12.1 Prerarrangement for electrical connection

The machine is pre-configured for the installation of end limit switch.

Proceed as follows to connect the end limit switch to the machine:

- open the door electrical box;
- pass the cables for connection through the hole "A".
- connect the end limit switch to the XT1-27BEL and XT1-27AB terminal blocks;

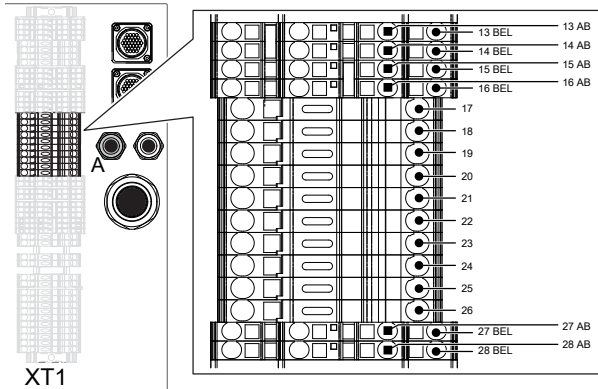

CAUTION
Make sure to install the end limit switch properly.

E.13 Positioning of emergency switches

If rack handling systems are connected at the infeed or outfeed of a rack-type dishwasher, install on such systems emergency switches that are clearly visible and identifiable and easily accessed by the operator "R" who must use them.

Described below are possible couplings of dishwashers "L" with rack handling systems "M", with the corresponding positions of the emergency switches "E" and work stations "R".

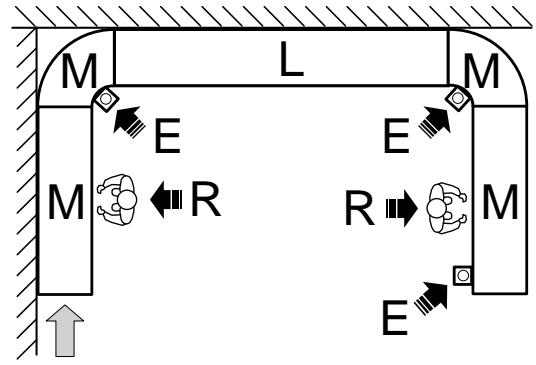
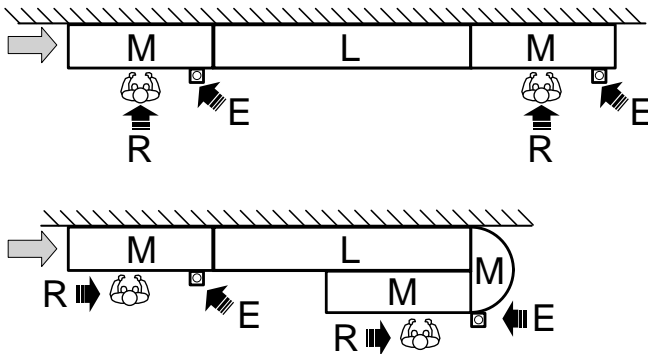

"R" Operator or work station

"L" Dishwasher

"M" Rack handling systems

"E" Emergency switch

E.13.1 Electrical connection

Proceed as follows to connect the emergency switches to the machine:

1. open the door electrical box;
2. pass the cables for connection through the hole "A";
3. connect the emergency switches to:

Emergency switch IN

- XT1-14BEL and XT1-14AB terminal blocks

Emergency Switch OUT

- XT1-13BEL and XT1-13AB terminal blocks

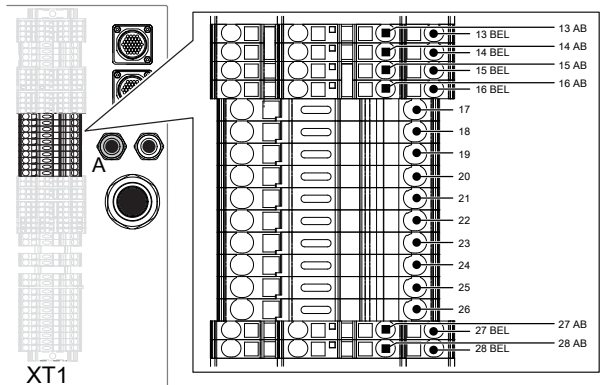

E.14 Exhaust fan electrical connection

By connecting the external suction fans, they are activated/deactivated when the machine is ready to operate or it is operating. Also, the fans are deactivated when a part of the machine is opened or the emergency switch is pressed, putting the entire installation in safe conditions.

If you need to connect external ventilation hood motors, connected to the machine according to the below pictures and table.

Open the door electric box and pass the cables for electrical connection through the hole "A".

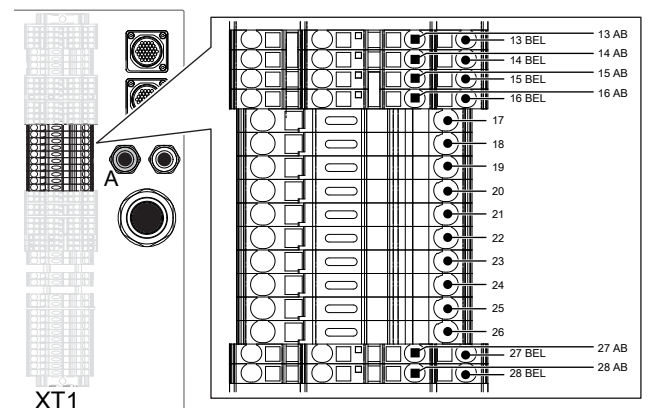

XT1-17	Fan signal (refer to the wiring diagram)
XT1-18	
XT1-19 [L1]	External power supply (230Vac - max 5A)
XT1-20 [N]	

E.15 Installation of detergent/rinse aid dispensers

The machine is pre-configured for installation of detergent and rinse aid dispensing devices.

The dispensers must be installed in a way that does not compromise machine operation or safety.



WARNING

Contact with chemical substances (e. g. detergent, rinse aid, scale remover, etc.) without taking appropriate safety precautions (e. g. personal protection equipment) can involve exposure to chemical risk and possible damage to health. Therefore always refer to the safety cards and labels on the products used.



CAUTION

Do not start the machine if the dispenser devices do not meet the safety requirements of "EC" Directives or current regulations in the country of use.



CAUTION

The use of "foaming"/non-specific detergents or in any case detergents used in different ways from that prescribed by the manufacturer, can cause damage to the dishwasher and compromise washing results.



NOTE!

To obtain excellence washing performance, use detergent, rinse aid and descaling agent suggested by Electrolux Professional. In the Electrolux Professional web site, open the "Accessories and Consumables" web page and navigate into the dishwashing equipment tab to order most suitable detergents and accessories.

E.15.1 Rinse aid dispenser

The left or right side panels of the dishwasher have a "T" injector [$\varnothing=6$ mm] for connecting the rinse aid dispenser.

To connect the dispenser, carefully carry out the following instructions:

- unscrewing the "U" fitting from the "T" injector;
- connect the rinse aid pipe, coming from the external dispenser, on the "U" fitting;
- screw the "U" fitting tightly to the "T" injector paying careful attention to any potential plumbing leaks.

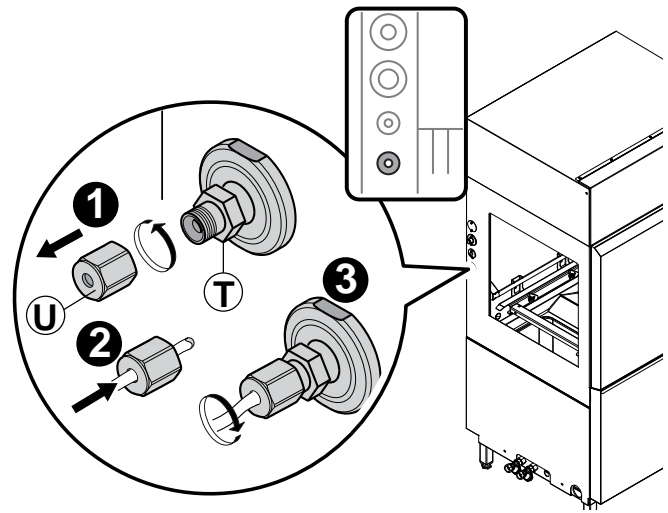

E.15.2 Liquid detergent dispenser

The left or right side panels of the dishwasher have a "P" injector [$\varnothing=6$ mm] for connecting the detergent dispenser.

To connect the dispenser, carefully carry out the following instructions:

- unscrewing the "R" fitting from the "P" injector;
- connect the detergent pipe, coming from the external dispenser, on the "R" fitting;
- screw the "R" fitting tightly to the "P" injector paying careful attention to any potential plumbing leaks.

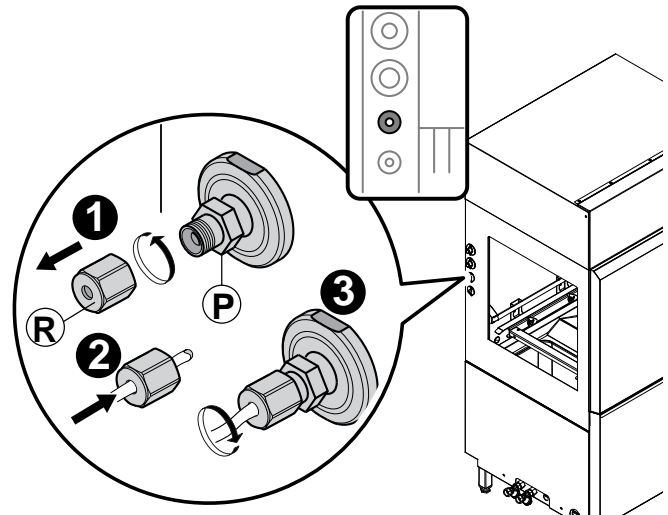

E.15.3 Solid detergent dispenser

The left and right side panels of the dishwasher have a hose union "P" for connecting the solid/powder detergent dispenser.

To connect the dispenser, carefully carry out the following instructions:

- fit the solid detergent pipe, coming from the external dispenser, on hose union "P";
- secure the pipe to the hose union with a clamp "B".

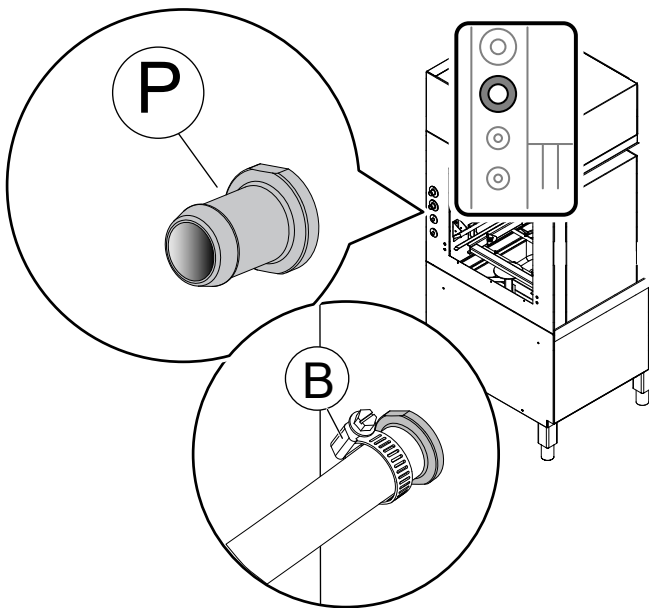

E.15.4 Delime hose connection

The left and right side panels of the dishwasher have a hose union "R" for connecting the delime hose.

To connect the hose, carefully carry out the following instructions:

- fit the delime pipe, coming from the external dispenser, on hose union "R";
- secure the pipe to the hose union with a clamp "B".

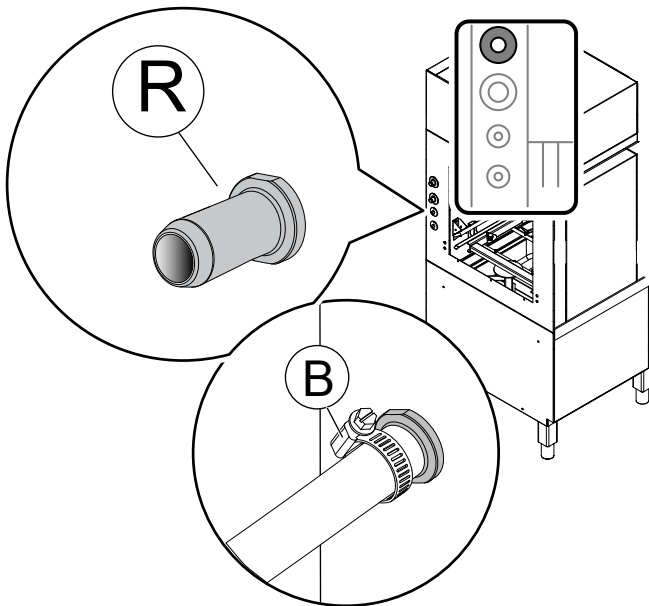

E.16 Dispensers electrical connection



CAUTION

Do not make direct connections on the printed circuits.



NOTE!

The connection cables must comply with the standards: CEI EN 60332, CEI EN 50265, CEI 20 - 35, CEI 20 - 20.

Open the door electric box and pass the cables for electrical connection through the hole "A".

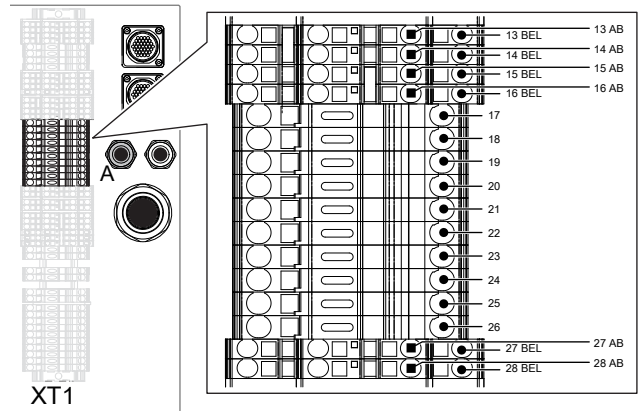

XT1-21	RINSE AID START SIGNAL (230Vac - max 2A)
XT1-22	
XT1-23	DETERGENT START SIGNAL (230Vac - max 2A)
XT1-24	
XT1-25	EXTERNAL DISPENSER POWER SUPPLY (230Vac - max 5A)
XT1-26	

E.16.1 Rinse aid dispenser

- Find the XT1 terminal block.
- Connect the rinse aid dispenser between terminals XT1-21 and XT1-22.

E.16.2 Liquid detergent dispenser

- Find the XT1 terminal block.
- Connect the dispenser between terminals XT1-23 and XT1-24.

E.16.3 Solid detergent dispenser

- Find the XT1 terminal block.
- Connect the dispenser between terminals XT1-25 and XT1-26.



IMPORTANT

Make sure to close the door of the electric box, firmly at the end of the installation.



NOTE!

For additional information, refer to the wiring diagram, supplied with the equipment.

E.17 Electrical connections



WARNING

Refer to "Safety Information".



CAUTION

The connection cable must be "H07RN-F" type, oil proof. Tighten the cables properly using a maximum torque of 6 Nm.

Make sure the machine power supply voltage specified on the data plate matches the mains voltage B.3 *Machine and manufacturer's identification data*.

Make sure the system power supply is arranged and able to take the actual current load and that it is executed in a workmanlike manner according to the regulations in force in the country of use.

The earth wire from the terminal board side must be longer (max 20 mm) than the phase wires. Connect the power cable earth wire to an efficient earth.

The machine must also be included in an equipotential system, whose connection is made by means of screw EQ (see par. *Installation diagram*) indicated by the symbol ∇ . The equipotential wire must have a section of at least 10 mm².

Connect the power cable to the equipment:

- open the door electrical box;

- pass the power cables through hole;
- connect the power cable to the main machine switch;

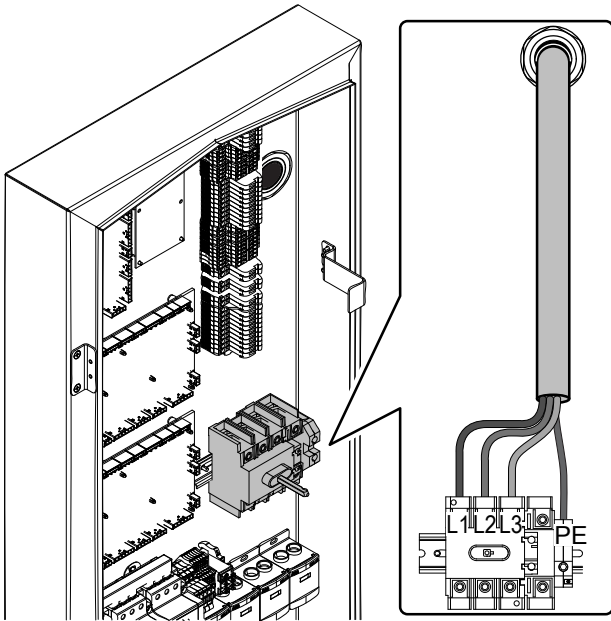

- activate all the contactors by turning clockwise the contactor knob from position "O" to "I";

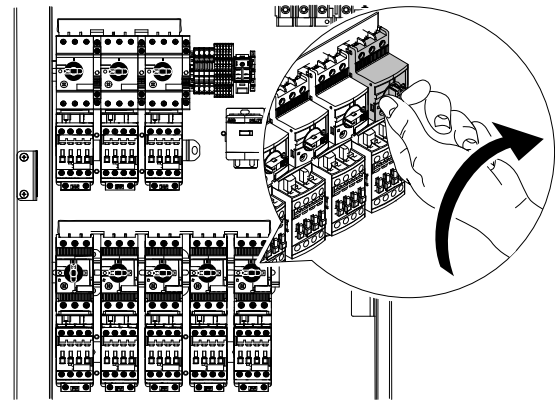

IMPORTANT

Make sure to close the door of the electric box, firmly at the end of the installation.



NOTE!

For additional information, refer to the wiring diagram, supplied with the equipment.

E.18 Fitting curtains

With the machine switched off and cold, fit or refit the curtains as illustrated below.

Machine curtains position

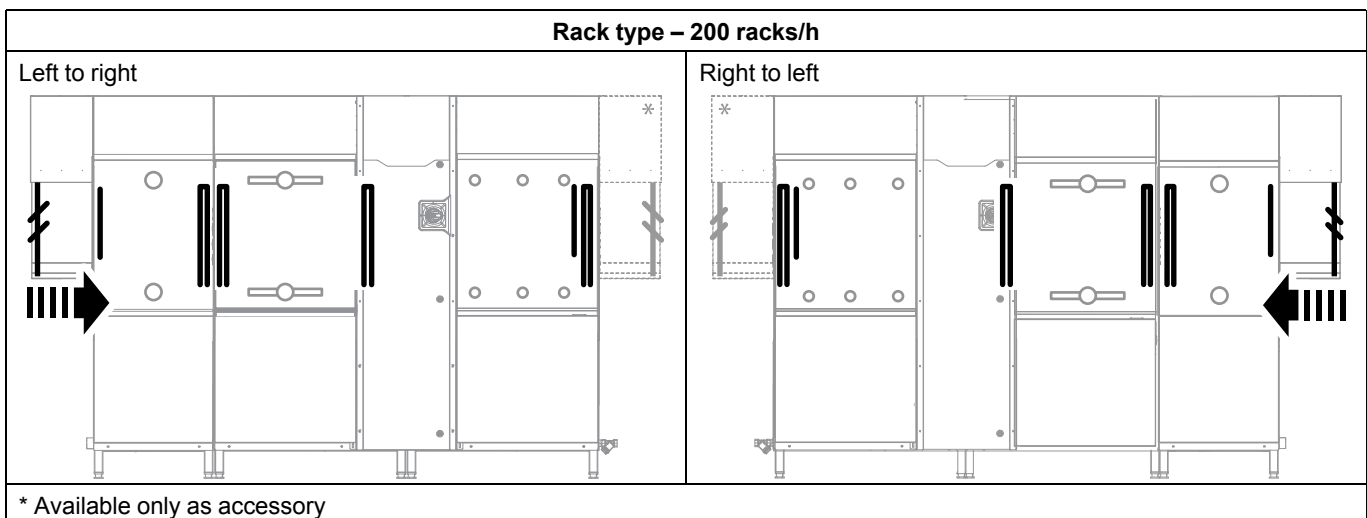
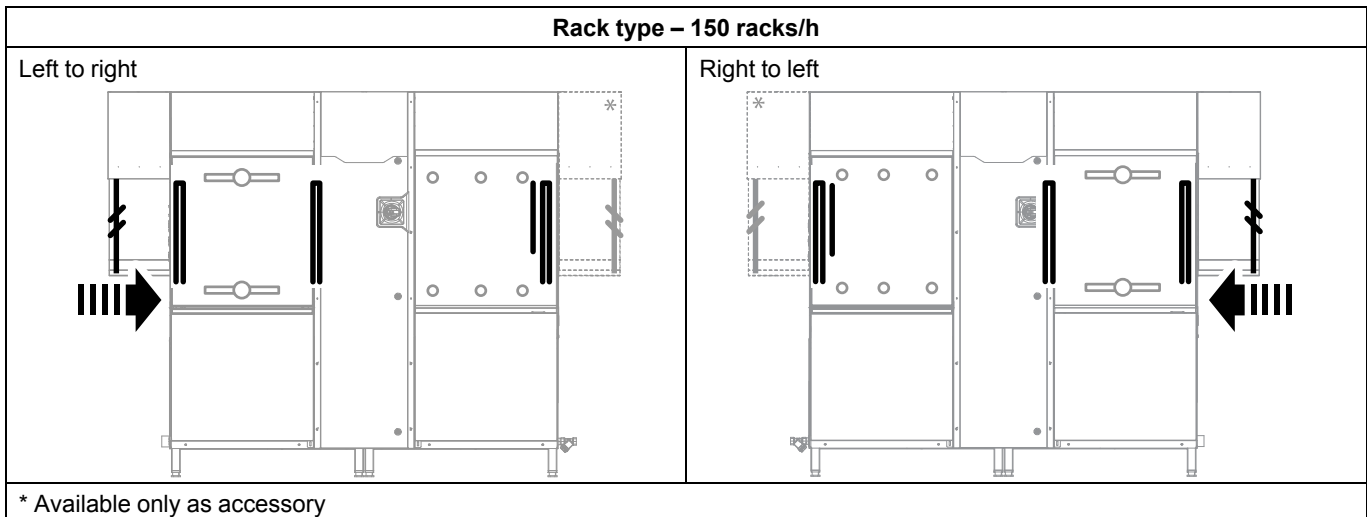

Types of curtains

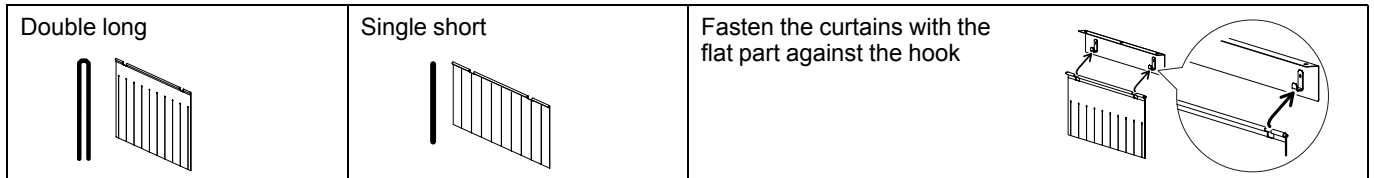

Hood curtains

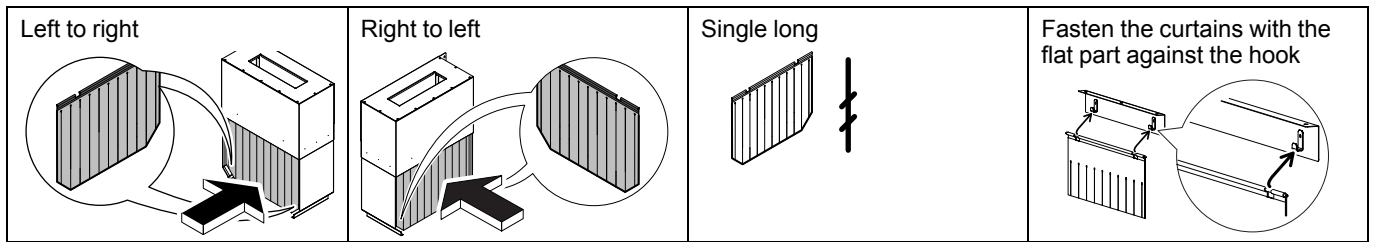

F CONTROL PANEL DESCRIPTION

F.1 Control panel overview

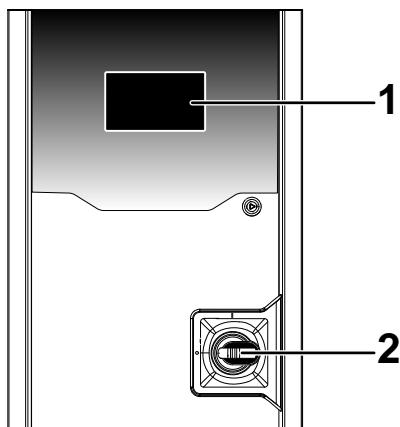

1	Touch screen with direct selection of functions. Touch the selected icons to activate the corresponding functions.
2	Switch disconnecter

F.2 Touch screen description

The machine works using a touchscreen with touch-sensitive icons.

Touch the icons on the screen to activate the requested actions or to see information related the machine, the wash cycle or any malfunctions.





NOTE!









This type of touch screen allows you to start, stop or change some settings in all of normal work conditions:

- hands with gloves;
- wet or dirty fingers.

Main touch screen icons

	Lower wash speed icon
	Medium wash speed icon

Main touch screen icons (cont'd.)

	Higher wash speed icon
	Pause icon. Touch it again to start the wash speed previously set.
	Touch this icon to activate "Pop Up menu"
	Touch this icon to deactivate "Pop Up menu"
	Touch this icon to come back to the previous menu
	Touch this icon to confirm your selection
	Touch this icon to scroll up the screen page
	Touch this icon to scroll down the screen page
	This icon appears when you have set a function and you want come back to the "Pop Up menu"

Pop Up menu

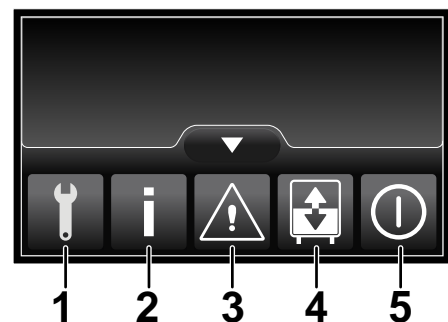

1	"Service" menu, protected by a password.
2	"Information" menu
3	"Alarm" menu
4	"Drain and Refill" menu
5	"Shutdown" menu

G COMMISSIONING

G.1 Preliminary checks, adjustments and operational tests

Before starting the machine, check:

1. electrical and plumbing connections;

2. positioning of tank components;
3. washing and rinse arms position and fitting;
4. curtains position and fitting.

These operations must only be carried out by specialized technicians provided with adequate personal protection equipment (refer to A.3 *Personal protection equipment*), tools and suitable ancillary equipment with the machine switched off and cold.

G.2 Electrical and plumbing connection

Before starting the machine, check:

1. correct connection of the electrical wires that feed the machine;
2. the power supply voltage and frequency match the data given in the technical data table (*C TECHNICAL DATA*);
3. correct connection of the water supply and drain pipes (*E.7 Plumbing connections*);
4. guards, safety devices and emergency switches are in place and properly installed.

G.3 Positioning and fitting of the tank components

Before starting the machine, check the fitting of filters and overflows of:

1. prewash 22" module, if present;

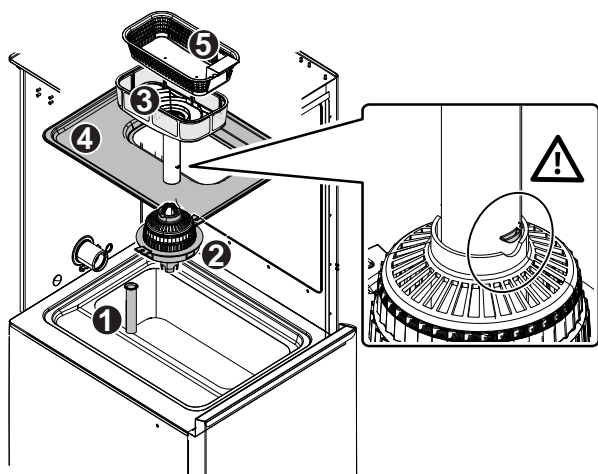

2. prewash 35" module, if present;

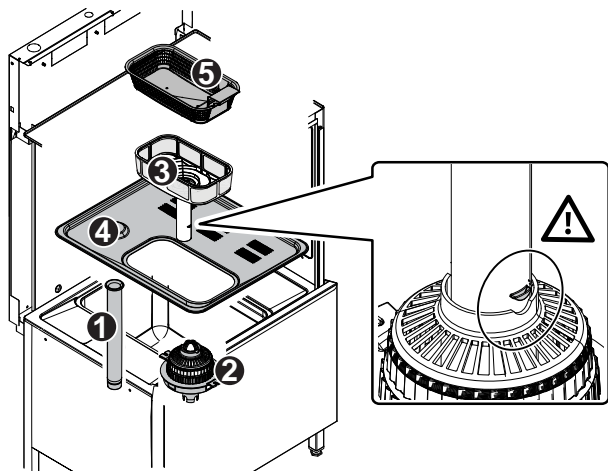

3. wash module;

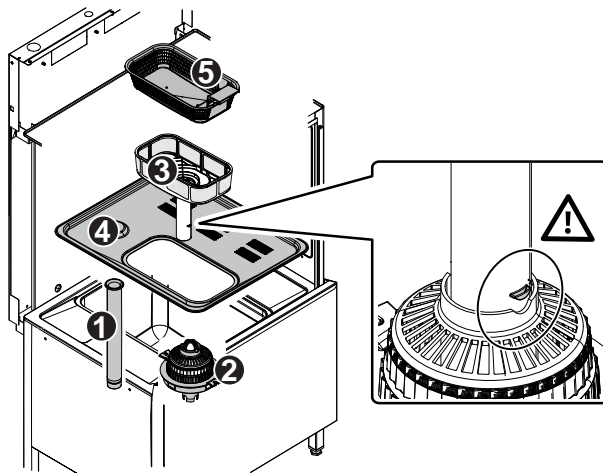

4. rinse module.
Right to left

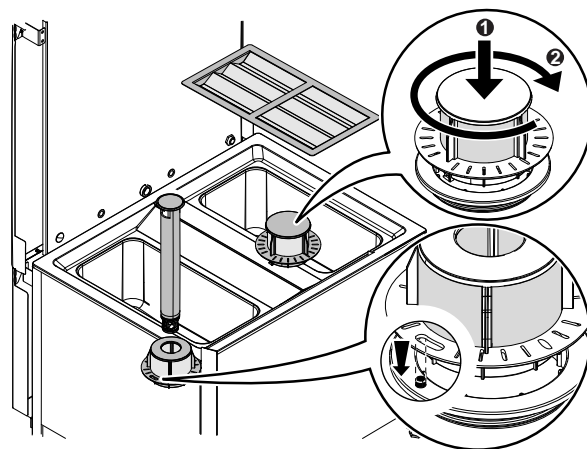

Left to right

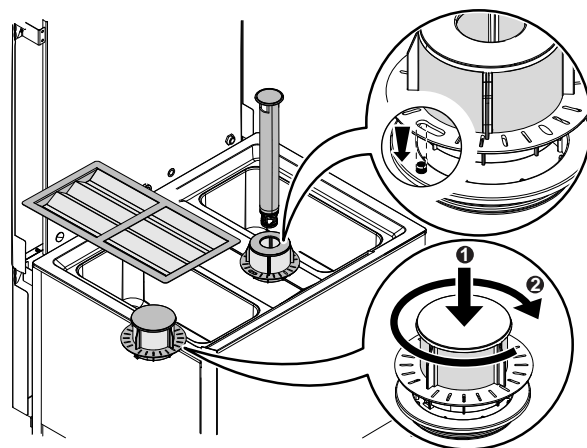

G.4 Positioning and fitting of the washing and rinse arms

Before starting the machine, check the fitting of upper and lower arms of:

1. prewash 22" module (if present);

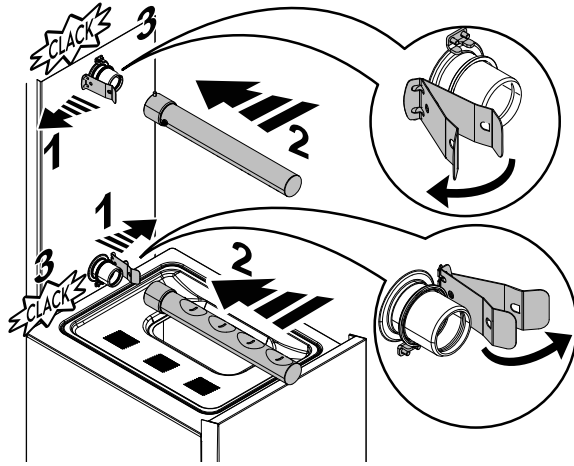

2. the arms of prewash and wash 35" module;

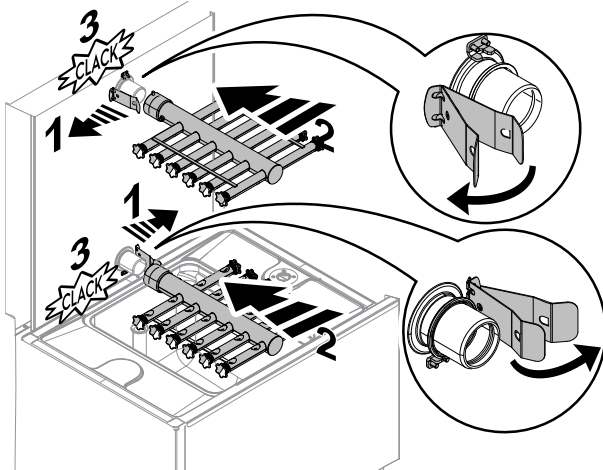

3. the arms of rinse module.

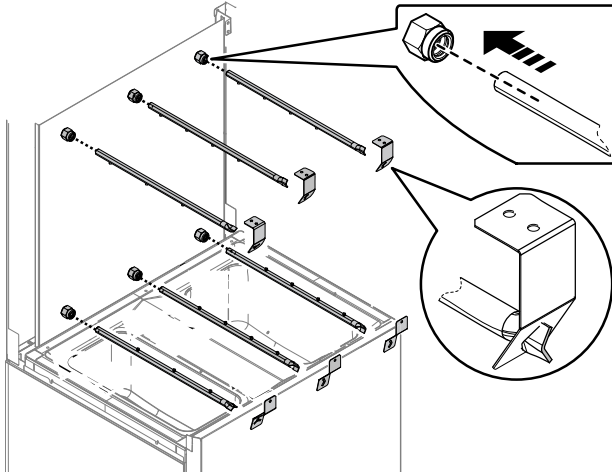

G.5 Positioning and fitting of the curtains

Make sure all the types of curtains, provided with the machine, are correctly fitted according to that indicated in paragraph "E.18 Fitting curtains".



IMPORTANT

Close the doors of the various appliance modules only when all the parts previously described are correctly installed, then start the machine.

G.6 First starting

1. Open the water supply taps.

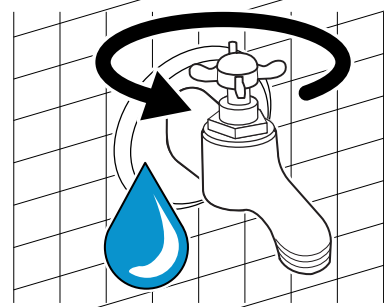

2. Turn the switch disconnecter, placed on the door of the electric cabinet, from position "O" to "I" to power the machine.
3. When the display shows the ready status, the dishwasher is ready to work.

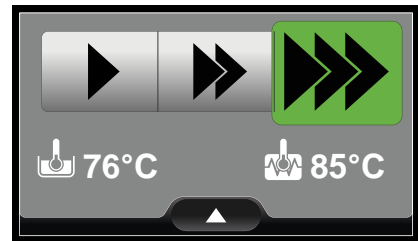



H BASIC MACHINE SETUP

H.1 Enter into service menu

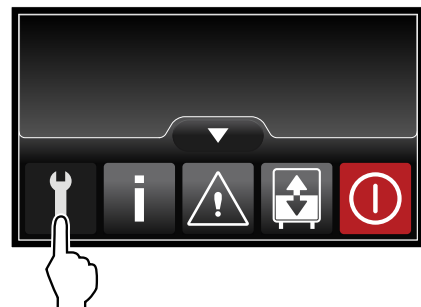

1. Touch the icon  to activate "Pop Up menu".

2. Touch the Service icon  to enter into Service Menu.

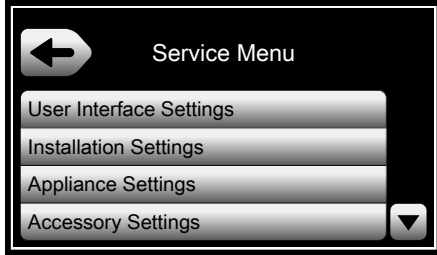
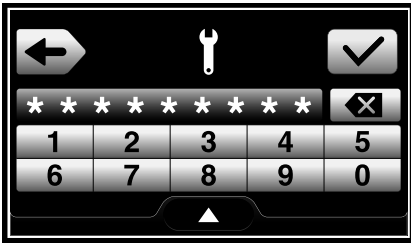

3. Insert the password "11111111" and touch the confirm icon  to log in the Service Menu.





4. To navigate into the Service menu, touch the page down  and page up  icon.

To confirm the selected option, touch the icon .

To return to the previous menu, touch the icon .

H.2 User Interface settings menu

To see all the options, touch page down  or page up  icon.

To confirm the selected option, touch the icon .

To return to the previous menu, touch the icon .

1. Set the "language".

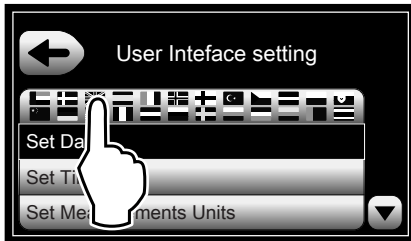

2. Find your language and confirm your selection.



3. Set "date" parameters.

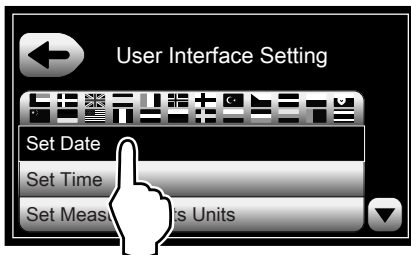

4. Set the format date.

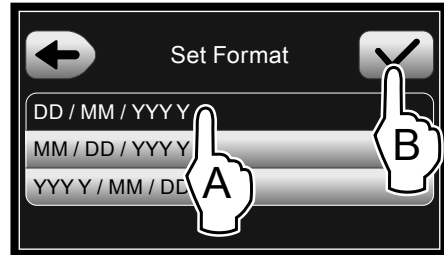
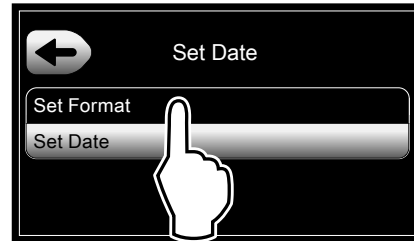

5. Set the current date.

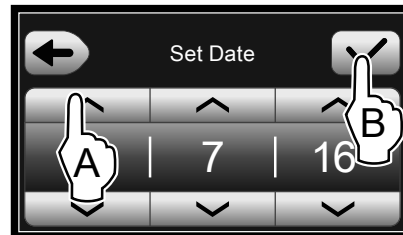

6. Set "time" parameters.

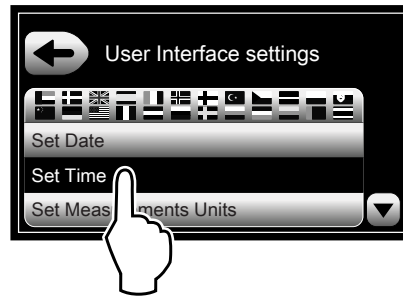

7. Set the time format.

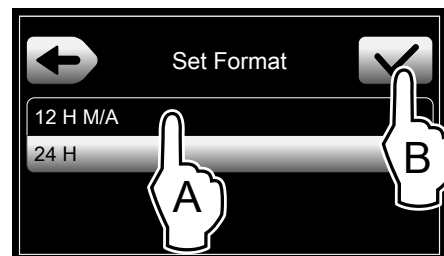
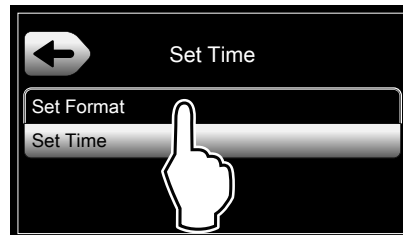

8. Set the current hour.



9. Set "measurements units" parameters.

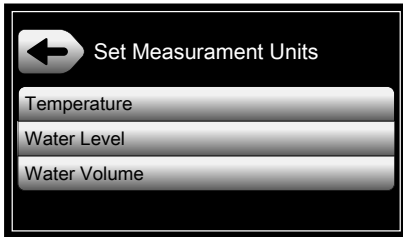
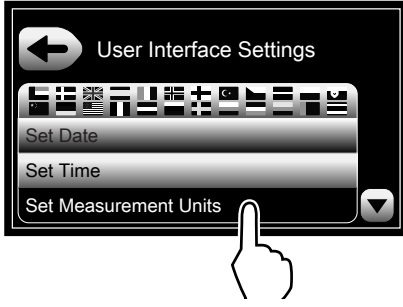

10. Set the temperature in Celsius or Fahrenheit [°C - °F].

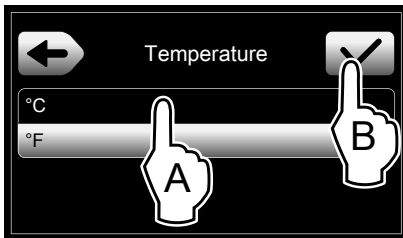

11. Set the water level in mm or inch.

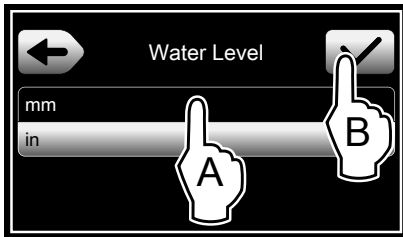

12. Set the water volume in litres or gallons.

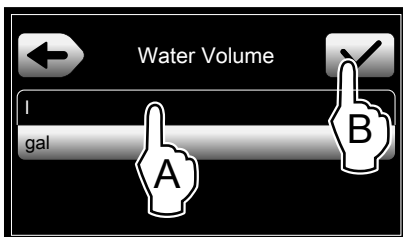

H.3 Installation settings menu

To see all the options available, touch page down ▼ or page up ▲ icon.

To confirm the selected option, touch the icon ✓.

To return to the previous menu, touch the icon ←.

1. Enter into the "Installation settings menu"

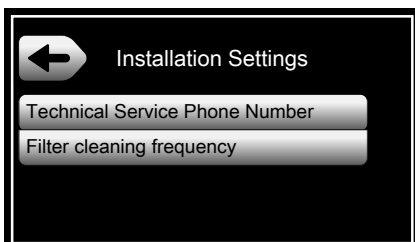

2. Insert the "Technical Service Phone Number".

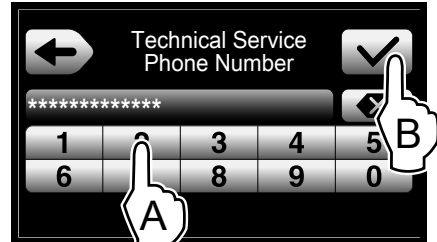

3. Set the "Filter cleaning frequency". The display shows you the default value. Insert the new value and confirm it.

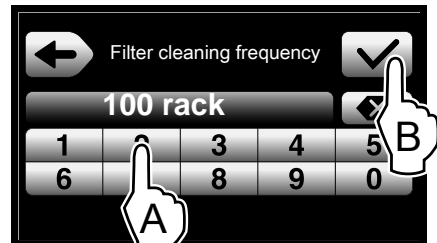
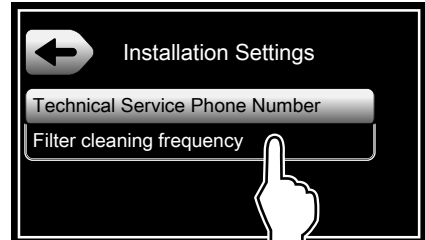

NOTE!

On the bottom part of the display, the minimum, maximum and the default values appears alternately.

Please ask to the customer the "Filter cleaning frequency" parameters. It depends on the type of tableware that the dishwasher must wash.



IMPORTANT

- Only specialised personnel has the possibility to change other machine settings.
- Always refer to the "service manual" to change or modify machine settings.
- When the machine is in fault due to an error, the display shows the error code and the phone number of the Service Centre. It is important keep the phone number always updated.

CE

Electrolux Professional SPA
Viale Treviso 15
33170 Pordenone
www.electrolux-professional.com