

ALPENINOX

Crio Touch 2 Door Freezer, LCD Touch screen, 1430 lt (-22/-15)

ITEM # _____

MODEL # _____

NAME # _____

SIS # _____

AIA # _____



728625 (CTO142FF)

2-door freezer 1430lt, -22-15°
C, LCD touch screen, AISI
304

Short Form Specification

Item No.

Two full door freezer entirely constructed in 304 AISI stainless steel with bottom panel in anti-corrosive material. Large external LCD touch display to allow: cabinet temperature indication; selection among 2 preset and 2 programmable food categories to adjust temperature to the type of food stored; HACCP history for critical high temperature, alarm service and full diagnostic; IQ Defrost 4 to defrost only when required with automatic evaporation of defrost water; probe failure indication and diagnostic. Airflow System: back to front forced air flow and removable air conveyors provide even temperature distribution and fast cooling in any conditions. Fitted with 75 mm-thick cyclopentane insulating foam. Door features lock and door microswitch to switch off the fan when the door is opened. Hidden evaporator to guarantee higher storage capacity and less corrosion problems. Built-in refrigeration unit and internal LED light. For ambient temperatures up to 43°C. CFC and HCFC free. R404a gas in refrigeration circuit. Supplied with n. 8x2/1GN A304 stainless steel grids and n. 8 sets of 2 stainless steel grid runners. Provided with USB port to download temperature history and additional port to connect to a remote computer or integrated HACCP system.

Main Features

- Large storage area suitable to contain 2/1 GN grids or shelves on anti-tilt runners.
- Cabinet fitted with up to 75 mm thickness of cyclopentane insulation for best insulating performance with 100% environmental protection (thermal conductivity: 0,020 W/m²K).
- Automatic evaporation of the defrosting water by hot gas on the top for energy saving.
- Provided with stainless steel A304 grids.
- Optiflow: back to front forced air flow and removable air conveyors provide even temperature distribution and fast cooling in any conditions.
- Interior LED light to save energy and for best internal visibility.
- Internal structure with numerous charging positions available to host grids, ensuring higher net capacity and a greater storage space.
- Intelligent door frame heater, activated according to external temperature, avoids condensation build-up around the door frame.
- 60 mm-thick insulation covering the evaporator can be easily removed with a single operation.
- Removable triple-chamber balloon magnetic gasket to improve insulation and reduce energy consumption and ease of cleaning.
- Improved defrost and evaporator fan management – defrost type changes with temperature set-point: electric below +2° C while air convection defrost above +2°C, thus saving energy.
- Airflow: back to front forced air flow and removable air conveyors provide even temperature distribution and fast cooling in any conditions.
- Large external LCD touch display features the following benefits and advanced electronic functions:
 - Cabinet temperature indication
 - 2 selectable preset and 2 programmable food categories to set the appropriate temperature according to the type of food stored
 - HACCP: acoustic and visual alarms are activated when temperature exceeds critical limits. Up to 99 events are recorded and stored
 - IQ Defrost4: defrost cycle driven by 4 probes and activated only when ice in the evaporator is detected
 - Failure indication: history of alarm events and performances of the last 48h of operation are stored in case of probe failure
 - Diagnostic: four probes constantly control the working conditions of the appliance
 - Turbo cooling cycle to rapidly cool warm loads
- Tropicalized unit (43°C ambient temperature).
- This appliance is intended for use in ambient temperatures up to 40°C.
- Freezer model has operating temperatures that can be adjusted from -22 to -15 °C.

APPROVAL: _____

Construction

- CFC and HCFC-free insulation.
- Interior base with rounded corners, pressed from a single sheet.
- Lockable door.
- Refrigerant type: R404a.
- Constructed from the highest quality AISI 304 Stainless steel.
- The rounded internal corners, the easily removable runners, grids and air conveyors allow for ease of cleaning and high hygiene standards.
- Door switch stops the fan when door is opened to avoid cold air exiting the cell, thus saving energy.
- Anti-corrosion bottom avoids any damage that may be caused to the cabinet by aggressive detergents employed to clean the floors.
- IP21 protection index.

Included Accessories

- 8 of AISI 304 stainless steel grid with 2 runners, 2/1GN PNC 881018

Optional Accessories

- 2 stainless steel runners for refrigerated cabinets - (Marine) PNC 880242
- 1/1GN set of 8 PVC containers for fish PNC 880243
- Spacer for 670L and 1430L refrigerated cabinets PNC 880248
- Kit to fit 20 pastry trays (400x600mm) PNC 880333
- Kit of 6 swivelling wheels (2 with brake), diam 50mm PNC 880340
- Plastic container with false bottom, 1/1GN PNC 880705
- 4 swivelling wheels (2 with brake) for refrigerators, diam 125mm, NOT for glass door and remote models PNC 881002
- 2/1GN gray rilsan grid PNC 881004
- AISI 304 stainless steel grid, 2/1GN PNC 881016
- AISI 304 stainless steel grid with 2 runners, 2/1GN PNC 881018
- 2/1GN gray rilsan grid with 2 runners PNC 881020
- Set of 2 stainless steel runners for 670/1430L refrigerators and freezers PNC 881021
- Pedal opening for 1430L refrigerators PNC 881033
- PVC container with lid and 2 runners, 2/1GN PNC 881039
- 2/1GN perforated shelf PNC 881042
- 1/1GN rilsan steel wire basket h150mm PNC 881043
- 3 gray rilsan central grids for 1430L (not for glass door) PNC 881044
- 2/1GN gray rilsan basket + 2 runners h150mm PNC 881047

Front

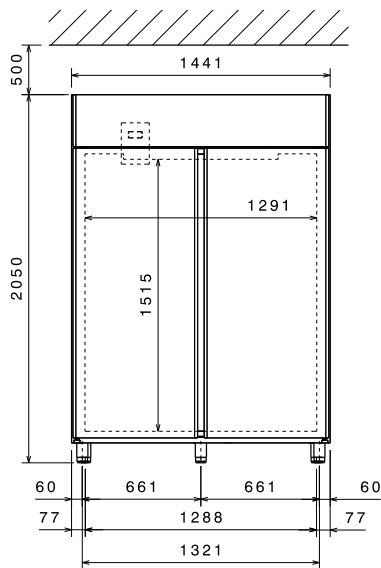

Side

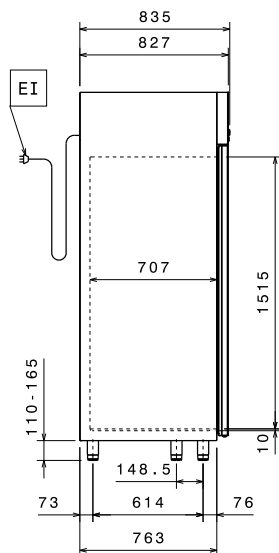

EI = Electrical inlet (power)

Top

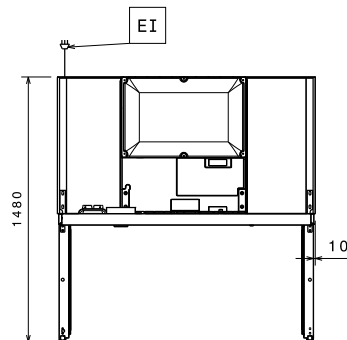

Electric

Supply voltage:

728625 (CT0142FF) 220-230 V/1 ph/50 Hz

Electrical power max.:

0.94 kW

Key Information:

Gross capacity:	1430 lt
Net Volume:	1135 lt
N° of doors:	2
Door hinges:	
External dimensions, Width:	1441 mm
External dimensions, Height:	2050 mm
External dimensions, Depth:	835 mm
External dimensions, Depth with Doors Open:	1480 mm
Number and type of grids (included):	8 - GN 2/1
Type of external material:	304 AISI
Type of internal material:	304 AISI
Internal panels material:	304 AISI
Number of positions & pitch:	44; 30 mm

Refrigeration Data

Control type:	Electronic
Refrigerant type:	R404A
Refrigeration power:	965 W
Refrigeration power at evaporation temperature:	-30 °C
Operating temperature min.:	-22 °C
Operating temperature max.:	-15 °C
Operating mode:	Ventilated
Cooling unit:	Built-In
Defrost type:	Electric

Product Information (EU Regulation 2015/1094)

Energy Class:	D
Yearly and daily energy consumption:	4774kWh/year - 13kWh/24h
Climate class:	Heavy Duty (5)
Energy Efficiency Index (EEL):	67,56

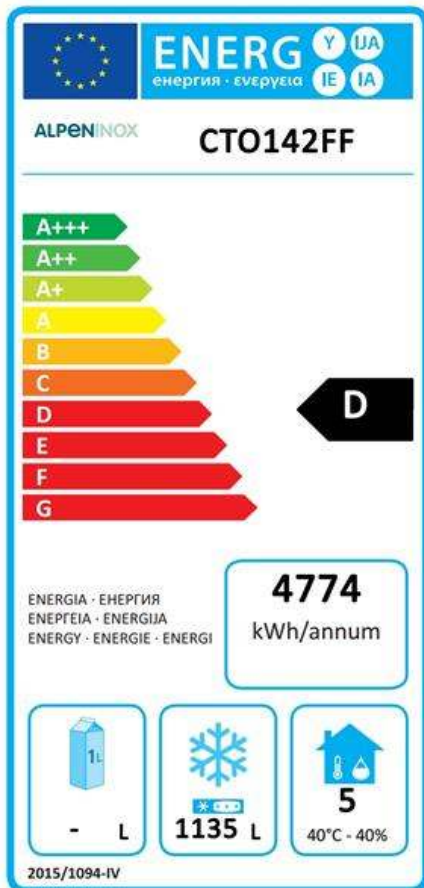

EU energy labelling from 1st July 2016

The European energy labelling scheme for professional refrigerators and freezers is based on requirements setting Minimum Energy Performance standards for commercial refrigeration cabinets sold within the EU. These requirements are designed to drive energy efficiency and environmentally friendly approach for professionals. The European energy labelling scheme will apply to all manufacturers and importers who sell and market products within the EU and it is mandatory across Europe.

Important: all products which consume energy above the minimum level will not be able to be sold within the EU from 1 July 2016.