

ALPENINOX

Pastry and Bakery Line 3 Door Freezer Counter, -24°/-10° C, 600X400 grid - Upstand

ITEM # _____

MODEL # _____

NAME # _____

SIS # _____

AIA # _____

ALPENINOX

3 Door Freezer Counter, -24°/-10°C, 600X400 grid - Upstand
Pastry and Bakery Line

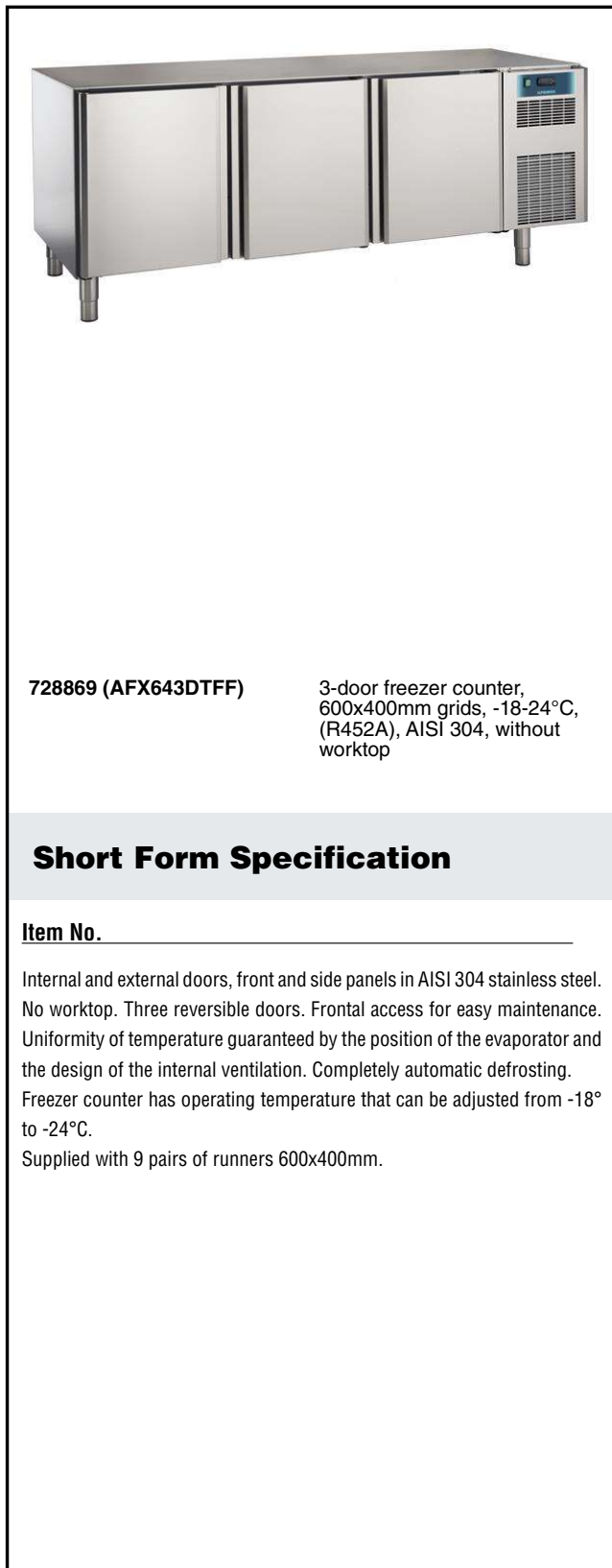

Main Features

- Frontal access for easy maintenance.
- Pressed stainless steel door handle without joints gathering dust and dirt.
- Completely automatic defrosting.
- Automatic evaporation of the defrosting water by heating element.
- Suitable for use in ambient temperature of up to 40°C (climatic class 5).
- Large digital digit display with cabinet temperature display and setting.
- Internal runners removable without any tools for faster cleaning operations.
- Adjustable temperature range from -18°C to -24°C.

Construction

- On site reversible left/right doors.
- Stainless steel AISI 304 inside and outside (except background).
- Insulation thickness: 50 mm wall insulation.
- 3 compartments with 3 doors.
- The position of the evaporator and the design of the internal ventilation facilitate the uniformity of the temperature.
- Environmentally friendly: R452a as refrigerant gas.

Included Accessories

- 9 of Pair of L runner, 600x400mm PNC 728874

Optional Accessories

- Pair of L runner, 600x400mm PNC 728874
- Stainless steel grid, 600x400mm for pastry counters PNC 728876

APPROVAL: _____

Front

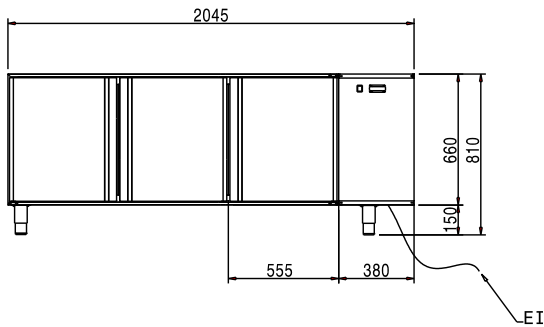

Side

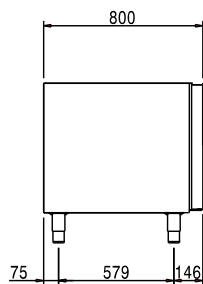

EI = Electrical inlet (power)

Top

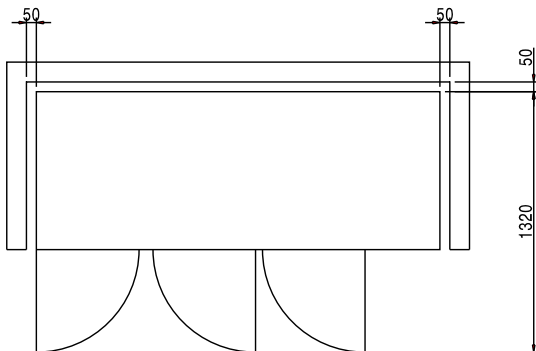

Electric

Supply voltage:

728869 (AFX643DTFF) 230 V/1N ph/50 Hz

Electrical power max.:

0.63 kW

Key Information:

Gross capacity:

510 lt

N° of doors:

3

Door hinges:

2 Right

External dimensions, Width:

2045 mm

External dimensions, Height:

810 mm

External dimensions, Depth:

800 mm

External dimensions, Depth with

Doors Open:

1320 mm

Type of external material:

Stainless Steel AISI 304 Scotch
Brite

Type of internal material:

304 AISI

Internal side panels material:

304 AISI

Refrigeration Data

Control type:

Electronic

Refrigerant type:

R452A

Refrigeration power at
evaporation temperature:

-30 °C

Operating temperature min.:

-24 °C

Operating temperature max.:

-18 °C

Product Information (EU Regulation 2015/1094)

Type of model:

counter frozen