

Crio Line HP Refrigerated Premium Saladette - 290lt, 2-Door

ITEM # _____

MODEL # _____

NAME # _____

SIS # _____

AIA # _____



712025 (AH2SBAA)

2-door refrigerated counter, saladette with cut-out for containers, 290L, -2+10°C, (R290), AISI 304

Short Form Specification

Item No.

External and internal in AISI 304 stainless steel, galvanized back panel. Extra insulation: 90mm body insulation to minimize energy dispersion, fitted with cut-out for n. 4 GN 1/3 containers (not included) and stainless steel lid. N. 2 full doors. Built-in refrigeration unit. Ventilated operating mode. Evaporator. Electronic microprocessor control with external digital temperature display. Automatic defrost. Operating temperature: -2+10°C. CFC and HCFC free. R290 gas in refrigeration circuit. Gas in foam: Cyclopentane. Supplied with n. 2X1/1GN rilsan coated grids.

Main Features

- Adjustable temperature range from -2 °C to +10 °C to suit meat, fish and dairy storage requirements.
- Large digital white-digit display with humidity selection button (3 preset level), internal temperature display and setting, manual activation of defrost cycle and turbo frost cycle (to rapidly cool warm loads).
- Equipped with Airflow system: forced air circulation system for rapid cooling and even temperature distribution within the cell.
- Tropicalized unit (43°C ambient temperature).
- Fitted with 90 mm thickness of cyclopentane insulation for best insulating performance (thermal conductivity: 0,020 W/m*K) and lowest environmental impact (GWP=3).
- 0mm clearance installation space: tower configuration cooling unit guarantee performance with frontal ventilation only; this unique solution allows installation against the wall or side by side with other appliances, even on the cooling unit side to maximize the use of kitchen space.
- IQ Defrost - fully automatic defrost starts only when ice is actually building-up in the evaporator and adapts the defrosting duration to guarantee perfect ice removal while optimizing energy efficiency consumption.
- Combination of doors and drawers to suit any configuration needed, with the possibility to change the configuration on site. Right cooling unit available on request.
- Fully removable cooling unit to facilitate maintenance.
- Frontal and easy access to all components in the cooling unit.
- Fully compliant HACCP digital control: when temperature exceeds critical limits, acoustic and visual alarms are activated. Up to two months of event are kept in memory.
- Anti-tilt runners accept GN 1/1 containers.
- Self closing stainless steel doors (< 90°).
- Certified safety CE requirements.
- Prearranged to fit RS485 port to facilitate connection to a remote computer and integrated HACCP systems.
- Hot gas automatic evaporation of defrost water.
- Hydrocarbon refrigerant gas R290 for the lowest environmental impact (GWP=3) - CFC and HCFC free.
- Cut-out worktop suitable for 4 GN 1/3 trays.
- Stainless steel lid for non-operating periods.
- No cross-contamination between upper and lower part (nothing will fall in the lower compartment).
- Large front working top (400 mm depth).
- CFC and HCFC free, highly ecological refrigerant type: R290 (ecological gas in foam: cyclopentane). Hydrocarbon refrigerant gas R290 for the lowest environmental impact (GWP=3), to reduce green house and ozone depletion effects.

APPROVAL: _____

Construction

- 2 compartments with 2 doors.
- Worktop in AISI 304 Stainless steel with a 50 mm profile.
- If needed, working top can be removed for easier handling during installation (in case of narrow doors).
- Anti-drip profile on stainless steel worktop edge.
- Interior base with rounded corners, pressed from a single sheet.
- Ease of cleaning and high hygiene standards thanks to the rounded internal corners, the easily removable runners, grids and air conveyors.
- Removable triple-chamber balloon magnetic gasket to improve insulation and reduce energy consumption and ease of cleaning.
- Internal structure with 15 charging positions (3 cm pitch) available to host GN 1/1 grids, ensuring higher net capacity and a greater storage space.
- Internal and external doors, front and side panels and removable worktop in AISI 304 Stainless steel.
- Mounted on stainless steel feet to give 150 mm (-5/+50 mm) clearance for ease of cleaning the floor.
- Built-in refrigeration unit.
- Developed and produced in ISO 9001 and ISO 14001 certified factory.
- Fault code display.
- IP21 protection index.

Included Accessories

- 2 of Kit 1/1GN gray rilsan grid and 2 side runners for refrigerated counters PNC 881109

Optional Accessories

- 1/1GN gray rilsan grid for refrigerated counters PNC 881107
- 2 side runners for 1/1GN refrigerated counters PNC 881108
- Kit 1/1GN gray rilsan grid and 2 side runners for refrigerated counters PNC 881109
- 1/1GN plastic container, h65mm PNC 881110
- 1/1GN plastic container, h100mm PNC 881111
- 1/1GN plastic container, h150mm PNC 881112
- Lock for refrigerated counters with 2 compartments PNC 881242



Front

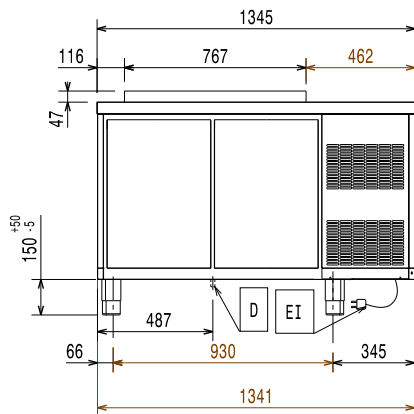

Side

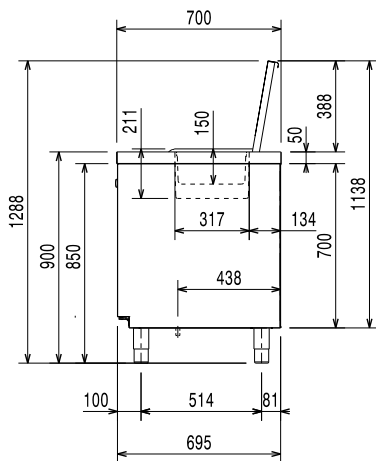

EI = Electrical inlet (power)

Top

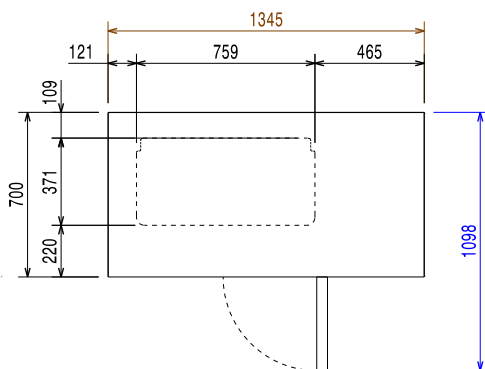

Electric

Supply voltage:	712025 (AH2SBAA)	220-240 V/1 ph/50 Hz
Electrical power max.:		0.25 kW
Defrost Power:		
Current consumption:		1.8 Amps
Plug type:		CE-SCHUKO

Key Information:

Gross capacity:	290 lt
Net Volume:	152 lt
Door hinges:	
External dimensions, Width:	1345 mm
External dimensions, Height:	900 mm
External dimensions, Depth:	700 mm
Internal Dimensions (depth):	560 mm
Internal Dimensions (height):	550 mm
Internal Dimensions (width):	798 mm
Net weight:	110 kg
Shipping volume:	1.13 m ³
Depth with doors open:	1110 mm
Height adjustment:	0/0 mm

Refrigeration Data

Control type:	Digital
Compressor power:	1/4 hp
Refrigerant type:	R290
GWP Index:	3
Refrigeration power:	320 W
Refrigeration power at evaporation temperature:	-10 °C
Refrigerant weight:	70 g
Min/Max internal humidity:	40/85
Operating temperature min.:	-2 °C
Operating temperature max.:	10 °C
Operating mode:	Ventilated