

Blast Chiller Freezers Crosswise Blast Chiller-Freezer Crosswise - 25 kg 5GN 1/1 (R452A) undercounter

ITEM # _____

MODEL # _____

NAME # _____

SIS # _____

AIA # _____



729686 (ACBCFA025UE)

CRIO Chill Tech blast chiller & freezer 25kg, undercounter, compatible with 6x1/1GN convection oven - R452A

Short Form Specification

Item No.

Blast chiller/freezer with digital temperature and time display. For 5 GN 1/1 or 600x400 mm trays (h = 65 mm). Load capacity: chilling 25 kg; freezing 15 kg. Automatic detection of food probe insertion. Automatic and Manual defrost. Blast chilling real remaining time estimation (A.R.T.E.). Turbo cooling function. Thawing function. HACCP and Service alarms with data logging. Connectivity ready. Operating air temperature: +10/-36°C. Single sensor food probe. Main components in 304 AISI stainless steel. Suitable for undercounter installation. Internal rounded corners and drain. Evaporator with antirust protection. Performances guaranteed at ambient temperature of +40°C. Cyclopentane insulation (HCFC, CFC and HFC free). R452a refrigerant gas (HCFC and CFC free). Built-in refrigeration unit.

Main Features

- Chilling cycle with automatic preset cycles:
 - Soft Chilling (air temperature 0°C), ideal for delicate food and small portions.
 - Hard Chilling (air temperature -12°C), ideal for solid food and whole pieces.
- Turbo cooling: chiller works continuously at the desired temperature; ideal for continuous production.
- Thawing cycle (air temperature 7°C), ideal for defrosting food in a controlled and safe environment.
- Possibility to modify the cavity temperature in turbo cooling and thawing cycles.
- Remaining time estimation for probe-driven cycles based on artificial intelligence techniques (ARTE) for an easier planning of the activities.
- Single sensor core probe as standard.
- Control unit provides two large displays to read out: time, core temperature, cycle countdown, alarms, service information.
- On-board HACCP monitoring capable.
- Connectivity ready for real time access to connected appliances from remote and HACCP monitoring (requires optional accessory).
- Performance guaranteed at ambient temperatures of +40°C (Climatic class 5).
- Automatic and manual defrosting.
- Blast Chilling cycle: 25 kg from 90°C up to 3°C in less than 90 minutes.
- Freezing cycle with automatic preset cycles (air temperature -36°C), ideal for all kind of food (raw, half or fully cooked).
- Working temperature from +90°C to +3°C in chilling mode or to -36°C in freezing mode.

Construction

- No water connections required.
- Ventilator swinging hinged panel for access to the evaporator for cleaning.
- Waste water can be plumbed into drain, but can also be collected in an optional waste container.
- Environmentally friendly: R452a as refrigerant gas.
- Built-in refrigeration unit.
- Removable magnetic door gasket with hygienic design.
- 5 levels available. Usable with 5 GN 1/1 or 600x400 mm trays (h = 65 mm).
- Main components in 304 AISI stainless steel.
- Evaporator with antirust protection.
- Hygienic shape with rounded corners (and drain for easy cleaning).
- Automatic heated door frame.
- Door reversible on site.
- Door stopper to keep the door open in order to avoid the formation of bad smells (kit available to be mounted on site, depending on preferred door hinge).
- IP21 protection index.

Sustainability

- Holding at +3 °C for chilling or -20 °C for freezing, automatically activated at the end of each cycle, to save energy and maintain the target temperature (manual

APPROVAL: _____

activation is also possible).

- High density polyurethane insulation, 60 mm tickness, HCFC free.



**Blast Chiller Freezers Crosswise
Blast Chiller-Freezer Crosswise - 25 kg 5GN 1/1 (R452A) undercounter**

The company reserves the right to make modifications to the products without prior notice. All information correct at time of printing.

Included Accessories

- 1 of 1 single sensor probe for blast chiller and blast chillers&freezer PNC 880213

Optional Accessories

- Kit of HACCP advanced connection for blast chiller and blast chillers/freezers PNC 880183
- 1 single sensor probe for blast chiller and blast chillers&freezer PNC 880213
- 2 single sensor probes for blast chiller-freezer PNC 880214
- Rilsan grid 600x400mm PNC 880864
- Plastic coated grid for refrigerated counters PNC 881061
- Kit 4 feet for blast chiller/freezers crosswise 15-25 kg - h100mm PNC 881295
- Kit 4 wheels for blast chiller/freezers crosswise 15-25 kg - h100mm PNC 881296
- Stacking kit for 6 GN 1/1 convection oven on 15&25 kg blast chiller/freezer crosswise PNC 881528
- Pair of 1/1GN grids in 304 AISI PNC 921101
- IoT module for CRIO Chill Tech blast chiller/freezers PNC 922419

Front

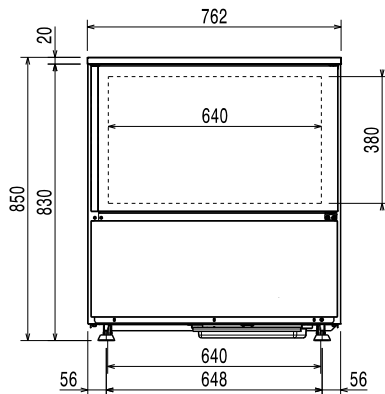

Side

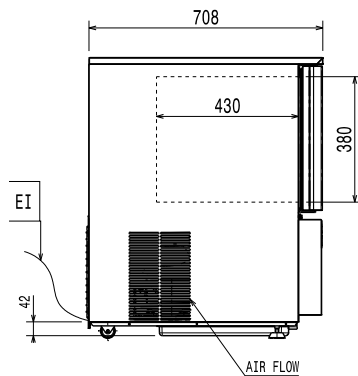

EI = Electrical inlet (power)

Top

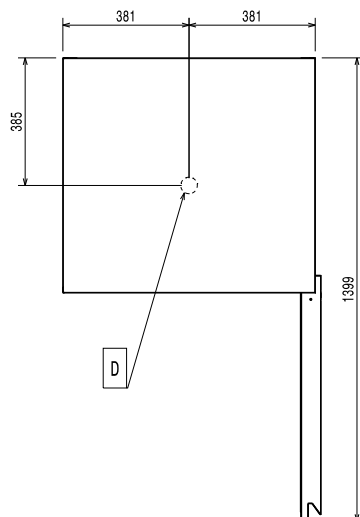

Electric

Supply voltage:
729686 (ACBCFA025UE) 220-240 V/1 ph/50 Hz
Electrical power max.: 1.6 kW
Circuit breaker required

Installation:

Clearance: 5 cm on sides and back.
Please see and follow detailed installation instructions provided with the unit

Capacity:

GN: 20 - 1/1 containers

Key Information:

External dimensions, Width: 762 mm
External dimensions, Depth: 708 mm
External dimensions, Height: 850 mm
Net weight: 105 kg
Shipping weight: 97 kg
Shipping volume: 0.88 m³

Refrigeration Data

Refrigeration power at evaporation temperature: -20 °C
Condenser cooling type: AIR

Product Information (EN17032 – Commission Regulation EU 2015/1095)

Chilling Cycle Time (+65°C to +10°C): 100 min
Full load capacity (chilling): 25 kg
Freezing Cycle Time (+65°C to -18°C): 261 min
Full load capacity (freezing): 15 kg

Test performed in a test room at 30°C to chill/ freeze (+10°C/-18°C) a full load of 40mm deep trays filled with mashed potatoes evenly distributed up to a height of 35 mm at starting temperature between 65° and 80°C within 120/270min.

Sustainability

Refrigerant type: R452A
GWP Index: 2141
Refrigeration power:
Refrigerant weight: 850 g
Energy consumption, cycle (chilling): 0.1012 kWh/kg
Energy consumption, cycle (freezing): 0.3453 kWh/kg