

## Ice Cuber 80kg/24h with 40kg bin - Water-cooled (Marine)

ITEM # \_\_\_\_\_

MODEL # \_\_\_\_\_

NAME # \_\_\_\_\_

SIS # \_\_\_\_\_

AIA # \_\_\_\_\_

### Main Features

- Compliant to CE requirements for safety.
- Fully automatic in operation.
- Operates over a wide range of temperatures.
- Suitable for gravity drain only (no pumps needed).
- Rated output is at an ambient air temperature of 21°C and water supply temperature of 15°C.
- Compact dimensions of the ice cubers make them highly suitable for any location, particularly those where space is at a premium.
- Model available in water-cooled version.
- The ice-making method (spray layering) guarantees crystalline, compact, hygienically pure ice cubes that are resistant to melting.
- Ice cube cone shape with the trunk sides slightly squashed.
- Bin integrated as standard.
- Water consumption and productivity calculated using 15°C water temperature and 21°C ambient temperature.

### Construction

- Plug as standard (schuko type).
- AISI 304 stainless steel exterior.
- Stainless steel spray arms removable without the use of tools.
- Reliability guaranteed by the quality of the construction materials used (plastic flap on the front, top and sides in 304 AISI stainless steel) and the sophisticated product and process technology involved.
- The inox sprayers are easy to take away, permit a simple flowing and prevent limestone formation.
- Internal ice cubes container in ABS.
- Adjustable feet 110-150 mm.
- Environmentally friendly: R452a as refrigerant gas.

730587 (CIM15WB)

Ice maker, cube, 80kg/24h,  
40kg ice collection bin  
included, water-cooled  
(Marine)

### Short Form Specification

Item No. \_\_\_\_\_

AISI 304 stainless steel exterior. Food grade ABS interior. Stainless steel spray arms removable without the use of tools. Fully automatic in operation. Efficient water cooling system. Suitable for gravity drain only. Flexible water supply and drain hoses. A spray system produces solid, crystal clear ice cubes.

Rated output is at an ambient air temperature of 21°C and water supply temperature of 15°C.

Self-contained storage bin capacity: 40 Kg.

APPROVAL: \_\_\_\_\_

**Side**

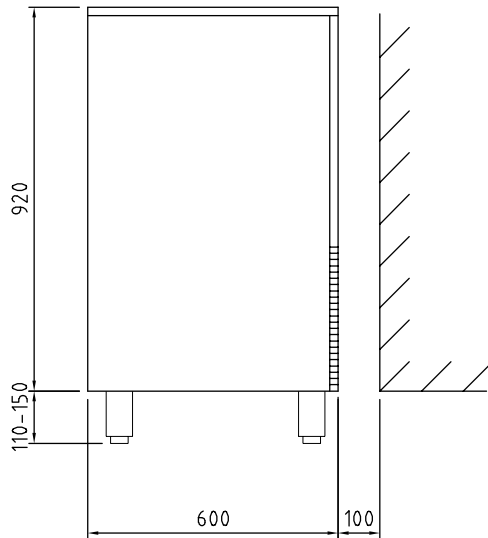

**Top**



- CW11** = Cold Water inlet 1 (cleaning)
- D** = Drain
- EI** = Electrical inlet (power)

**Front**

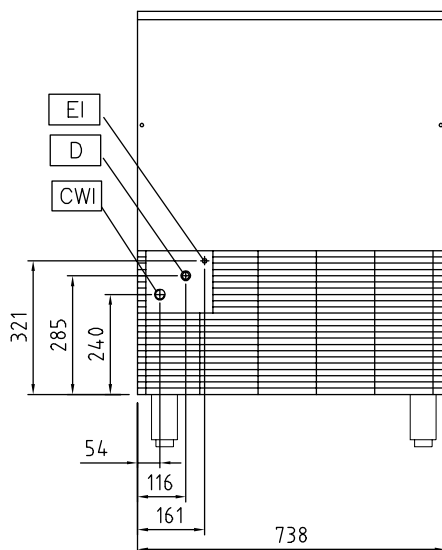

### Electric

Supply voltage:	730587 (CIM15WB)	230 V/1N ph/60 Hz
Electrical power max.:		0.8 kW

### Capacity:

Bin capacity:	40 kg
---------------	-------

### Key Information:

External dimensions, Width:	738 mm
External dimensions, Height:	920 mm
External dimensions, Depth:	600 mm
Net weight:	86 kg
Noise level:	57,8 dBA
Output:	80 kg/day
Kind of cube:	Ice Cube 18 g

### Refrigeration Data

Refrigerant type:	R452A
-------------------	-------