

CRIO Chill Smart Blast Chiller Crosswise 6 1/1 - 15kg

ITEM # _____

MODEL # _____

NAME # _____

SIS # _____

AIA # _____



728210 (EABP0101)

Blast chiller 15kg, compatible with 6x1/1GN crosswise oven (R134a)

Short Form Specification

Item No. _____

For 6 GN1/1 or 600x400 mm trays. Load capacity: chilling 15 kg; (UK guidelines). Main components in 304 AISI stainless steel. Internal rounded corners and drain. Left hinged, reversible full door. Built-in refrigeration unit. Automatic detection of food probe insertion. Automatic and Manual defrost. Blast chilling real residual time estimation (A.R.T.E.). Turbo cooling function. Specific cycles for ice cream. Evaporator with antirust protection. Digital temperature and time display. HACCP and Service alarms with data logging. Operating air temperature: +90 -12°C. For ambient temperatures up to 32° C. Cyclopentane insulation (HCFC, CFC and HFC free). R134a refrigerant gas (HCFC and CFC free).

Main Features

- Blast Chilling cycle: 15 kg from 90°C up to 3°C in less than 90 minutes.
- Hard Chilling (air temperature -12°C).
- Holding at 3 °C for chilling, automatically activated at the end of each cycle, to save energy and maintain the target temperature (manual activation is also possible).
- Turbo cooling: chiller works continuously at the desired temperature; ideal for continuous production.
- Control unit provides two large displays to read out: time, core temperature, cycle countdown, alarms, service information.
- Two customizable cycles (P1 & P2) for each operating mode, allowing to set the time and air temperature. These programs can be converted into ice-cream specialized cycles (shape maintenance and holding).
- All information related to the different operating models are recorded: date, time, cycle, core temperature, holding temperature, HACCP accordance.
- Remaining time estimation for probe-driven cycles based on artificial intelligence techniques (ARTE) for an easier planning of the activities.
- Single sensor core probe as standard.
- Soft Chilling (air temperature -2°C).
- Performance guaranteed at ambient temperatures of +40°C.

Construction

- High density polyurethane insulation, 60 mm thickness, HCFC free.
- Magnetic, easy-to-remove heated gaskets.
- 304 AISI stainless steel construction throughout.
- Seamless hygienic inner cell with all rounded corners for easy cleaning.
- Swing hinged front panel for easy service access to main components.
- Ventilator swinging hinged panel for access to the evaporator for cleaning.
- No water connections required.
- Waste water can be plumbed into drain, but can also be collected in an optional waste container.
- Refrigerant type: R134a.

Included Accessories

- 1 of 1 single sensor probe for blast chiller and blast chillers&freezer PNC 880213

Optional Accessories

- Kit of HACCP advanced connection for blast chiller and blast chillers/freezers PNC 880183
- 1 single sensor probe for blast chiller and blast chillers&freezer PNC 880213
- Rilsan grid 600x400mm PNC 880864
- KIT WHEELS FOR 15KG BCF-H=150MM PNC 881052
- Plastic coated grid for refrigerated counters PNC 881061
- 4 wheels for blast chillers PNC 881097

APPROVAL: _____

- Kit for stacking 6x1/1GN oven and 15kg blast chillers and blast chillers/freezers PNC 881528
- Pair of 1/1GN grids in 304 AISI PNC 921101



Front

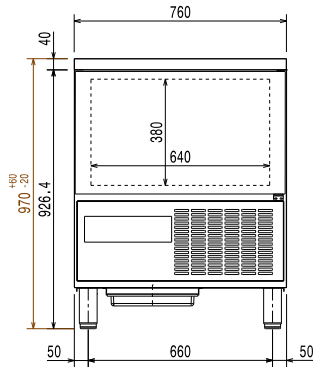

Side

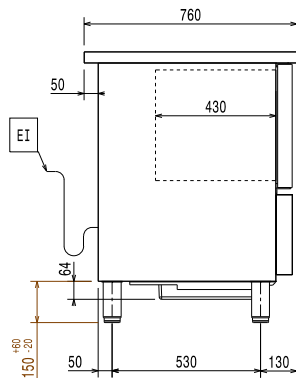

EI = Electrical inlet (power)
RO = Refrigerant Outlet

Top

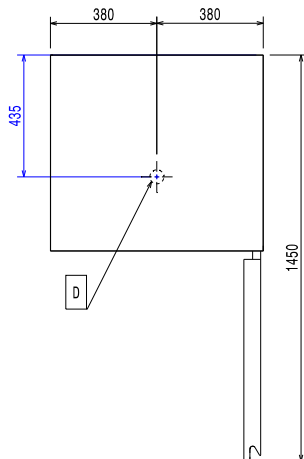

Electric

Supply voltage:
728210 (EABP0101) 220-230 V/1 ph/50 Hz
Electrical power max.: 0.77 kW
Circuit breaker required

Installation:

Clearance: 5 cm on sides and back.
Please see and follow detailed installation instructions provided with the unit

Capacity:

GN: 6 - 1/1 containers
Max load capacity: 15 kg

Key Information:

External dimensions, Width: 760 mm
External dimensions, Height: 970 mm
External dimensions, Depth: 760 mm
Net weight: 95 kg
Shipping weight: 105 kg
Shipping volume: 0.84 m³
Chilling-Freezing Productivity per cycle (NF Regulations): 10.8 kg - 0 kg
Chilling-Freezing Productivity per cycle (UK Guidelines): 15.2 kg - 0 kg

Refrigeration Data

Compressor power: 3/8 hp
Refrigerant type: R134a
Refrigeration power: 707 W
Refrigeration power at evaporation temperature: -5 °C
Refrigerant weight: 800 g

Product Information (Commission Regulation EU 2015/1095)

Energy consumption, cycle (chilling): 0.068 kWh/kg
Chilling Cycle Time (+65°C to +10°C): 111 min
Full load capacity (chilling): 20 kg
Energy consumption, cycle (freezing): 0 kWh/kg
Freezing Cycle Time (+65°C to -18°C): 0 min
Full load capacity (freezing): 0 kg