

## CRIO Line CP 2 Door Freezer Counter, 265lt (-20/-15) - Refrigeration unit on the right

ITEM # \_\_\_\_\_

MODEL # \_\_\_\_\_

NAME # \_\_\_\_\_

SIS # \_\_\_\_\_

AIA # \_\_\_\_\_

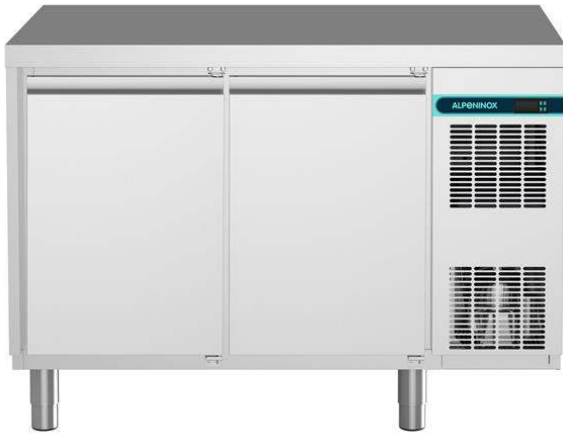

712405 (AK2KDAA)

2-door freezer counter, -20-15°C, (R290), AISI 304, with right cooling unit

### Short Form Specification

**Item No.** \_\_\_\_\_

Internal and external doors, front and side panels and worktop in 304 AISI stainless steel. N.2 doors. Built-in refrigeration unit on the right. Ventilated. Refrigerant R290. High-density expanded polyurethane foam, 90 mm in thickness, with cyclopentane injection. Digital control panel. Completely automatic defrosting and automatic evaporation of defrost water obtained by hot gas. Suitable to operate in ambient temperatures up to +38°C. Temperature range: -15/-20°C. CFC and HCFC free. Feet in 304 AISI stainless steel, adjustable in height.

### Main Features

- CFC and HCFC free, highly ecological refrigerant type: R290 (ecological gas in foam: cyclopentane). Hydrocarbon refrigerant gas R290 for the lowest environmental impact (GWP=3), to reduce green house and ozone depletion effects.
- IQ Defrost - fully automatic defrost starts only when ice is actually building-up in the evaporator and adapts the defrosting duration to guarantee perfect ice removal while optimizing energy efficiency consumption.
- Adjustable temperature range from -15°C to -22°C.
- Large digital white-digit display with humidity selection button (3 preset level), internal temperature display and setting, manual activation of defrost cycle and turbo frost cycle (to rapidly cool warm loads).
- Equipped with Airflow system: forced air circulation system for rapid cooling and even temperature distribution within the cell.
- Tropicalized unit (43°C ambient temperature).
- Fitted with 90 mm thickness of cyclopentane insulation for best insulating performance (thermal conductivity: 0,020 W/m\*K) and lowest environmental impact (GWP=3).
- 0mm clearance installation space: tower configuration cooling unit guarantee performance with frontal ventilation only; this unique solution allows installation against the wall or side by side with other appliances, even on the cooling unit side to maximize the use of kitchen space.
- Frontal and easy access to all components in the cooling unit.
- Fully compliant HACCP digital control: when temperature exceeds critical limits, acoustic and visual alarms are activated. Up to two months of event are kept in memory.
- Anti-tilt runners accept GN 1/1 containers.
- Self closing stainless steel doors (< 90°).
- Certified safety CE requirements.
- Prearranged to fit RS485 port to facilitate connection to a remote computer and integrated HACCP systems.
- Hot gas automatic evaporation of defrost water.

### Construction

- Fault code display.
- Interior base with rounded corners, pressed from a single sheet.
- Internal and external doors, front and side panels and removable worktop in AISI 304 Stainless steel.
- Worktop in AISI 304 Stainless steel with a 50 mm profile.
- Built-in refrigeration unit.
- Anti-drip profile on stainless steel worktop edge.
- Removable triple-chamber balloon magnetic gasket to improve insulation and reduce energy consumption and ease of cleaning.
- 2 compartments with 2 doors.
- If needed, working top can be removed for easier handling during installation (in case of narrow doors).
- Mounted on stainless steel feet to give 150 mm (-5/+50 mm) clearance for ease of cleaning the floor.
- External bottom panel in stainless steel.
- External back panel in galvanized steel.
- Ease of cleaning and high hygiene standards thanks to the rounded internal corners, the easily removable runners,

APPROVAL: \_\_\_\_\_

grids and air conveyors.

- Internal structure with 15 charging positions (3 cm pitch) available to host GN 1/1 grids, ensuring higher net capacity and a greater storage space.
- Extractable cooling unit to facilitate maintenance.
- IP21 protection index.
- Developed and produced in ISO 9001 and ISO 14001 certified factory.

### **Included Accessories**

- 2 of Kit 1/1GN gray rilsan grid and 2 side runners for refrigerated counters PNC 881109

### **Optional Accessories**

- 2x1/2-drawer kit refrigerated counter PNC 881079
- 3x1/3-drawer kit refrigerated counter PNC 881080
- 1/1GN gray rilsan grid for refrigerated counters PNC 881107
- 2 side runners for 1/1GN refrigerated counters PNC 881108
- Kit 1/1GN gray rilsan grid and 2 side runners for refrigerated counters PNC 881109
- 1/1GN plastic container, h65mm PNC 881110
- 1/1GN plastic container, h100mm PNC 881111
- 1/1GN plastic container, h150mm PNC 881112
- Kit 4 wheels, h100mm (2 with brakes) for refrigerated counters PNC 881191
- Kit 4 wheels, h150mm (2 with brakes) for 2&3 compartment refrigerated counters PNC 881193
- Lock for refrigerated counters with 2 compartments PNC 881242



**Side**

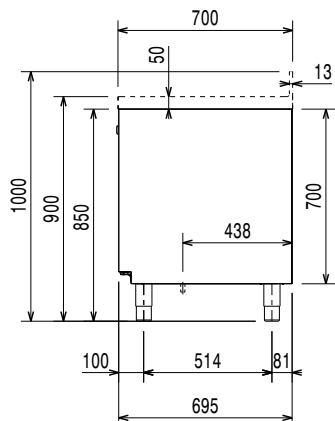

**Front**

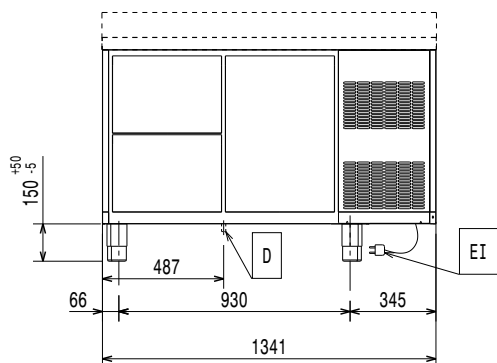

EI = Electrical inlet (power)

**Top**

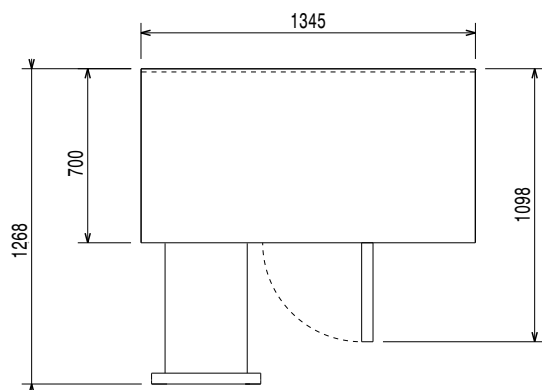

### Electric

Supply voltage:	712405 (AK2KDAA)	220-240 V/1 ph/50 Hz
Electrical power max.:		0.49 kW

### Key Information:

Gross capacity:	290 lt
Net Volume:	177 lt
N° of doors:	
Door hinges:	
External dimensions, Width:	1345 mm
External dimensions, Height:	900 mm
External dimensions, Depth:	700 mm
External dimensions, Depth with Doors Open:	1110 mm
Depth with doors open:	1110 mm
<b>Built-in Compressor and Refrigeration Unit</b>	

### Refrigeration Data

Control type:	Digital
Compressor power:	
Refrigerant type:	R290
Refrigeration power:	569 W
Refrigeration power at evaporation temperature:	-30 °C
Refrigerant weight:	145 g
Operating temperature min.:	-15 °C
Operating temperature max.:	-22 °C
Operating mode:	Ventilated
Defrost type:	

### Product Information (EU Regulation 2015/1094)

Energy Class:	C
Yearly and daily energy consumption:	1564kWh/year - 4.28kWh/24h
Climate class:	Heavy Duty (5)
Energy Efficiency Index (EEI):	45.82

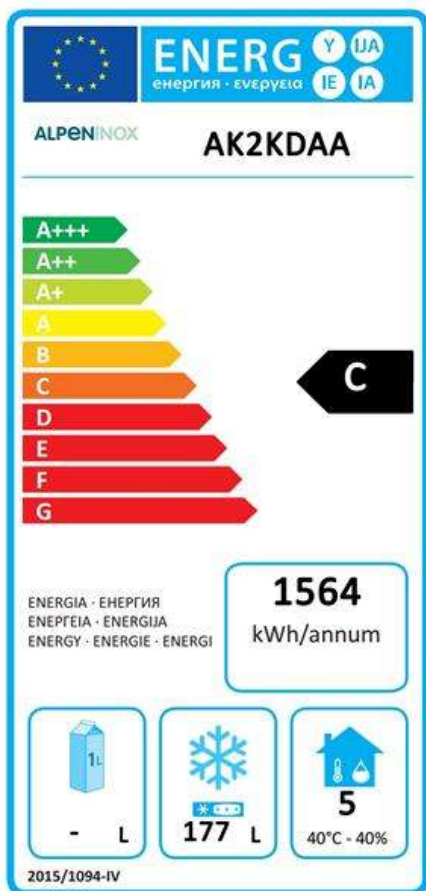

## EU energy labelling from 1st July 2016

The European energy labelling scheme for professional refrigerators and freezers is based on requirements setting Minimum Energy Performance standards for commercial refrigeration cabinets sold within the EU. These requirements are designed to drive energy efficiency and environmentally friendly approach for professionals. The European energy labelling scheme will apply to all manufacturers and importers who sell and market products within the EU and it is mandatory across Europe.

Important: all products which consume energy above the minimum level will not be able to be sold within the EU from 1 July 2016.