

## CRIO Line CP 1 Door & 2 Drawer Refrigerated Counter, 265lt (-2/+10) - Upstand (R290)

ITEM # \_\_\_\_\_

MODEL # \_\_\_\_\_

NAME # \_\_\_\_\_

SIS # \_\_\_\_\_

AIA # \_\_\_\_\_



721103 (AA2R3AB)

1-door and 2x1/2-drawer  
refrigerated counter with  
upstand, -2/+10°C, AISI 304  
(R290)

### Short Form Specification

**Item No.** \_\_\_\_\_

Internal and external doors, front and side panels and worktop in 304 AISI stainless steel. Worktop with splashback. N.1 door and n.2x1/2 drawers. Built-in refrigeration unit. Ventilated. Refrigerant R290. High-density expanded polyurethane foam, 90 mm in thickness, with cyclopentane injection. Digital control panel. Completely automatic defrosting and automatic evaporation of defrost water obtained by hot gas. Temperature range: -2/+10°C. CFC and HCFC free. Feet in 304 AISI stainless steel, adjustable in height.

### Main Features

- Tropicalized unit (43°C ambient temperature).
- IQ Defrost - fully automatic defrost starts only when ice is actually building-up in the evaporator and adapts the defrosting duration to guarantee perfect ice removal while optimizing energy efficiency consumption.
- Large digital white-digit display with humidity selection button (3 preset level), internal temperature display and setting, manual activation of defrost cycle and turbo frost cycle (to rapidly cool warm loads).
- Equipped with Airflow system: forced air circulation system for rapid cooling and even temperature distribution within the cell.
- Fitted with 90 mm thickness of cyclopentane insulation for best insulating performance (thermal conductivity: 0,020 W/m\*K) and lowest environmental impact (GWP=3).
- 0mm clearance installation space: tower configuration cooling unit guarantee performance with frontal ventilation only; this unique solution allows installation against the wall or side by side with other appliances, even on the cooling unit side to maximize the use of kitchen space.
- Combination of doors and drawers to suit any configuration needed, with the possibility to change the configuration on site. Right cooling unit available on request.
- Frontal and easy access to all components in the cooling unit.
- Fully compliant HACCP digital control: when temperature exceeds critical limits, acoustic and visual alarms are activated. Up to two months of event are kept in memory.
- Anti-tilt runners accept GN 1/1 containers.
- Self closing stainless steel doors (< 90°).
- Certified safety CE requirements.
- Prearranged to fit RS485 port to facilitate connection to a remote computer and integrated HACCP systems.
- Hot gas automatic evaporation of defrost water.
- Adjustable temperature range from -2 °C to +10 °C to suit meat, fish and dairy storage requirements.
- CFC and HCFC free (highly ecological refrigerant type: R290).
- CFC and HCFC free, highly ecological refrigerant type: R290 (ecological gas in foam: cyclopentane). Hydrocarbon refrigerant gas R290 for the lowest environmental impact (GWP=3), to reduce green house and ozone depletion effects.
- Connectivity ready for real time access to connected appliances from remote and data monitoring (requires optional accessory).

### Construction

- Extractable cooling unit to facilitate maintenance.
- Fault code display.
- Interior base with rounded corners, pressed from a single sheet.
- Internal and external doors, front and side panels and removable worktop in AISI 304 Stainless steel.
- Worktop in AISI 304 Stainless steel with a 50 mm profile.
- Built-in refrigeration unit.
- Anti-drip profile on stainless steel worktop edge.
- Removable triple-chamber balloon magnetic gasket to improve insulation and reduce energy consumption and ease of cleaning.

APPROVAL: \_\_\_\_\_

- If needed, working top can be removed for easier handling during installation (in case of narrow doors).
- Mounted on stainless steel feet to give 150 mm (-5/+50 mm) clearance for ease of cleaning the floor.
- Ease of cleaning and high hygiene standards thanks to the rounded internal corners, the easily removable runners, grids and air conveyors.
- Internal structure with 15 charging positions (3 cm pitch) available to host GN 1/1 grids, ensuring higher net capacity and a greater storage space.
- IP21 protection index.
- Developed and produced in ISO 9001 and ISO 14001 certified factory.
- Raised rear upstand permits unit to be connected up against the wall for better hygiene.
- Internal dimension of the drawers:
  - models with 2 1/2 drawers: 1st drawer (top drawer) 196x302x521 / 2nd drawer 198x302x521 (HxWxD)
  - models with 3 1/3 drawers: 1st and 2nd drawers (top and central drawer) 99x302x521 / 3rd drawers 103x302x521 (HxWxD)
  - models with 1/3+2/3 drawers: 1st drawer (top drawer) 99x302x521 / 2nd drawer 295x302x521 (HxWxD)

### Included Accessories

- 1 of Kit 1/1GN gray rilsan grid and 2 side runners for refrigerated counters PNC 881109

### Optional Accessories

- Kit integrated HACCP for digital refrigerators (IR33) PNC 880252
- 1/1GN gray rilsan grid for refrigerated counters PNC 881107
- 2 side runners for 1/1GN refrigerated counters PNC 881108
- Kit 1/1GN gray rilsan grid and 2 side runners for refrigerated counters PNC 881109
- 1/1GN plastic container, h65mm PNC 881110
- 1/1GN plastic container, h100mm PNC 881111
- 1/1GN plastic container, h150mm PNC 881112
- Worktop for refrigerated Crio Line CP and SB counters - 2 compartments PNC 881124
- Worktop and upstand for refrigerated Crio Line CP and SB counters - 2 compartments PNC 881127
- 2-drawer kit refrigerated counters PNC 881179
- 3x1/3-drawer kit for refrigerated counters PNC 881186
- 1/3 and 2/3 bottle drawer kit for refrigerated counters PNC 881187
- Kit 4 wheels, h100mm (2 with brakes) for refrigerated counters PNC 881191
- Kit 4 wheels, h150mm (2 with brakes) for 2&3 compartment refrigerated counters PNC 881193
- Lock for refrigerated counters with two compartments - h650mm PNC 881245

### Front

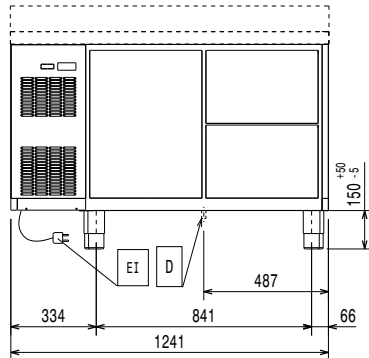

### Side

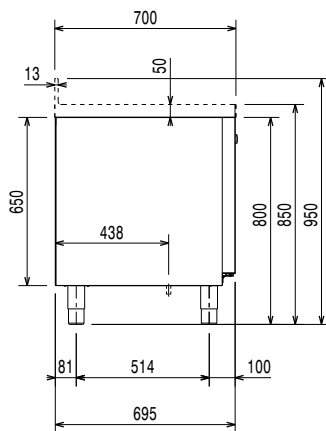

EI = Electrical inlet (power)

### Top

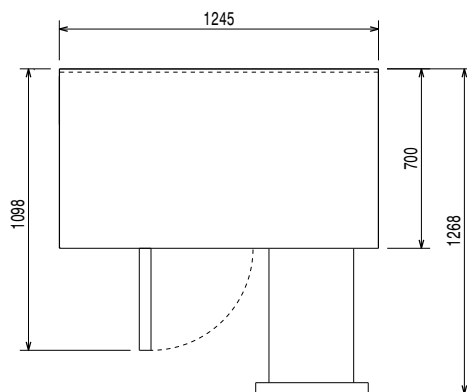

### Electric

#### Supply voltage:

721103 (AA2R3AB) 220-240 V/1 ph/50 Hz

#### Electrical power max.:

0.22 kW

### Key Information:

Net Volume: 136.399993896484 lt

#### Door hinges:

External dimensions, Width: 1245 mm

External dimensions, Height: 950 mm

External dimensions, Depth: 700 mm

External dimensions, Depth with Doors Open: 1110 mm

Depth with doors open: 1110 mm

#### Built-in Compressor and Refrigeration Unit

### Refrigeration Data

Control type: Digital

Compressor power: 0.25 hp

Refrigerant type: R290

Refrigeration power: 358 W

Refrigeration power at evaporation temperature: 0 °C

Refrigerant weight: 50 g

Min/Max internal humidity: 40/85

Operating temperature min.: -2 °C

Operating temperature max.: 10 °C

Operating mode: Ventilated

### Product Information (EU Regulation 2015/1094)

Energy Class: A

Yearly and daily energy consumption: 500kWh/year - 1kWh/24h

Climate class: Normal duty (cl.4)

Energy Efficiency Index (EEI): 23,38

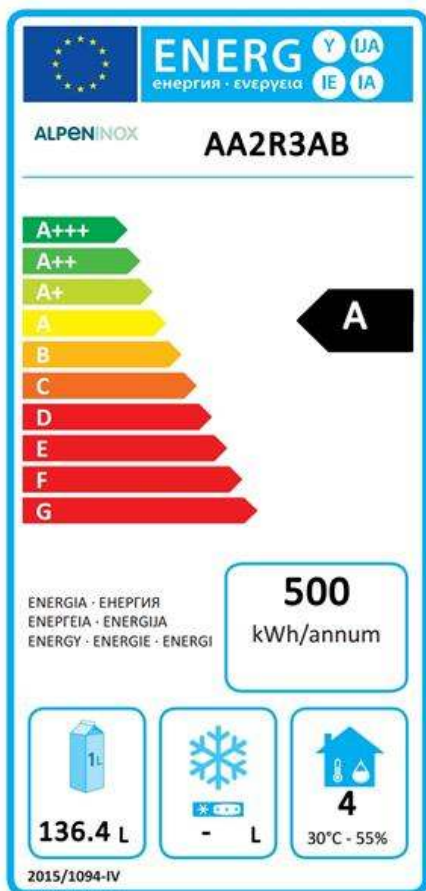

## EU energy labelling from 1st July 2016

The European energy labelling scheme for professional refrigerators and freezers is based on requirements setting Minimum Energy Performance standards for commercial refrigeration cabinets sold within the EU. These requirements are designed to drive energy efficiency and environmentally friendly approach for professionals. The European energy labelling scheme will apply to all manufacturers and importers who sell and market products within the EU and it is mandatory across Europe.

Important: all products which consume energy above the minimum level will not be able to be sold within the EU from 1 July 2016.