

## CRIO Line CP 1 Door and 2 Drawer Refrigerated Counter, 265lt with Splashback (R290)

ITEM # \_\_\_\_\_

MODEL # \_\_\_\_\_

NAME # \_\_\_\_\_

SIS # \_\_\_\_\_

AIA # \_\_\_\_\_



721021 (AK2R3AB)

1-door and 2x1/2-drawer  
refrigerated counter with  
upstand, -2+10°C, AISI 304  
(R290)

### Short Form Specification

#### Item No.

Internal and external doors, front and side panels and worktop in 304 AISI stainless steel. Worktop with splashback. N.1 door and n.2x1/2 drawers. Built-in refrigeration unit. Ventilated. Refrigerant R290. Extra insulation: 90mm body insulation to minimize energy dispersion. Digital control panel. Completely automatic defrosting and automatic evaporation of defrost water obtained by hot gas. Temperature range: -2+10°C. CFC and HCFC free. Feet in 304 AISI stainless steel, adjustable in height. Supplied with n.1x1/1GN Rilsan grid.

### Main Features

- Adjustable temperature range from -2 °C to +10 °C to suit meat, fish and dairy storage requirements.
- Large digital white-digit display with humidity selection button (3 preset level), internal temperature display and setting, manual activation of defrost cycle and turbo frost cycle (to rapidly cool warm loads).
- Equipped with Airflow system: forced air circulation system for rapid cooling and even temperature distribution within the cell.
- Tropicalized unit (43°C ambient temperature).
- Fitted with 90 mm thickness of cyclopentane insulation for best insulating performance (thermal conductivity: 0,020 W/m\*K) and lowest environmental impact (GWP=3).
- 0mm clearance installation space: tower configuration cooling unit guarantee performance with frontal ventilation only; this unique solution allows installation against the wall or side by side with other appliances, even on the cooling unit side to maximize the use of kitchen space.
- Combination of doors and drawers to suit any configuration needed, with the possibility to change the configuration on site. Right cooling unit available on request.
- IQ Defrost - fully automatic defrost starts only when ice is actually building-up in the evaporator and adapts the defrosting duration to guarantee perfect ice removal while optimizing energy efficiency consumption.
- Frontal and easy access to all components in the cooling unit.
- Fully compliant HACCP digital control: when temperature exceeds critical limits, acoustic and visual alarms are activated. Up to two months of event are kept in memory.
- Anti-tilt runners accept GN 1/1 containers.
- Self closing stainless steel doors (< 90°).
- Certified safety CE requirements.
- Prearranged to fit RS485 port to facilitate connection to a remote computer and integrated HACCP systems.
- Hot gas automatic evaporation of defrost water.
- CFC and HCFC free (highly ecological refrigerant type: R290).
- CFC and HCFC free, highly ecological refrigerant type: R290 (ecological gas in foam: cyclopentane). Hydrocarbon refrigerant gas R290 for the lowest environmental impact (GWP=3), to reduce green house and ozone depletion effects.

### Construction

- Fault code display.
- Interior base with rounded corners, pressed from a single sheet.
- Internal and external doors, front and side panels and removable worktop in AISI 304 Stainless steel.
- Worktop in AISI 304 Stainless steel with a 50 mm profile.
- Built-in refrigeration unit.
- Anti-drip profile on stainless steel worktop edge.
- Removable triple-chamber balloon magnetic gasket to improve insulation and reduce energy consumption and ease of cleaning.
- If needed, working top can be removed for easier handling during installation (in case of narrow doors).
- Mounted on stainless steel feet to give 150 mm (-5/+50 mm) clearance for ease of cleaning the floor.

APPROVAL: \_\_\_\_\_

- Ease of cleaning and high hygiene standards thanks to the rounded internal corners, the easily removable runners, grids and air conveyors.
- Internal structure with 15 charging positions (3 cm pitch) available to host GN 1/1 grids, ensuring higher net capacity and a greater storage space.
- Developed and produced in ISO 9001 and ISO 14001 certified factory.
- Raised rear upstand permits unit to be connected up against the wall for better hygiene.
- Extractable cooling unit to facilitate maintenance.
- IP21 protection index.
- Internal dimension of the drawers:
  - models with 2 1/2 drawers: 1st drawer (top drawer) 203x302x521 / 2nd drawer 223x302x521 (HxWxD)
  - models with 3 1/3 drawers: 1st drawer (top drawer) 98x302x521 / 2nd and 3rd drawers 118x302x521 (HxWxD)
  - models with 1/3+2/3 drawers: 1st drawer (top drawer) 98x302x521 / 2nd drawer 333x302x521 (HxWxD)

### Included Accessories

- 1 of Kit 1/1GN gray rilsan grid and 2 side runners for refrigerated counters PNC 881109

### Optional Accessories

- 2x1/2-drawer kit refrigerated counter PNC 881079
- 3x1/3-drawer kit refrigerated counter PNC 881080
- 1/3 and 2/3 bottle drawer kit for refrigerated counters PNC 881081
- 1/1GN gray rilsan grid for refrigerated counters PNC 881107
- 2 side runners for 1/1GN refrigerated counters PNC 881108
- Kit 1/1GN gray rilsan grid and 2 side runners for refrigerated counters PNC 881109
- 1/1GN plastic container, h65mm PNC 881110
- 1/1GN plastic container, h100mm PNC 881111
- 1/1GN plastic container, h150mm PNC 881112
- Kit 4 wheels, h100mm (2 with brakes) for refrigerated counters PNC 881191
- Kit 4 wheels, h150mm (2 with brakes) for 2&3 compartment refrigerated counters PNC 881193
- Lock for refrigerated counters with 2 compartments PNC 881242

**Front**

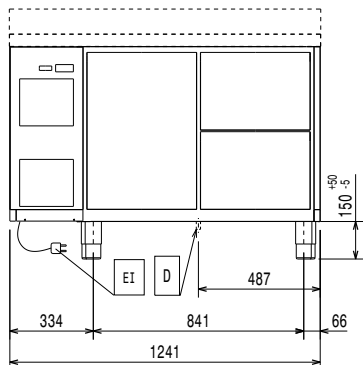

**Side**

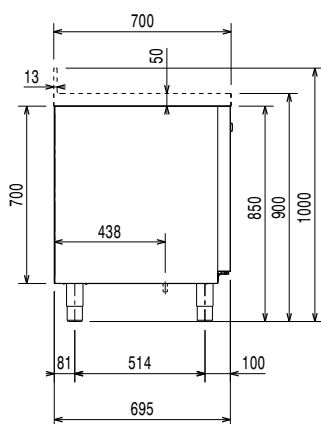

EI = Electrical inlet (power)

**Top**

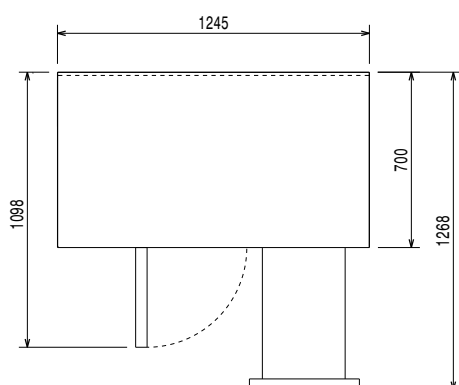

### Electric

Supply voltage:	721021 (AK2R3AB)	220-240 V/1 ph/50 Hz
Electrical power max.:		0.22 kW
Defrost Power:		0.2 kW

### Key Information:

Net Volume:	153 lt
Door hinges:	
External dimensions, Width:	1245 mm
External dimensions, Height:	1000 mm
External dimensions, Depth:	700 mm
Internal Dimensions (depth):	560 mm
Internal Dimensions (height):	550 mm
Internal Dimensions (width):	798 mm
Net weight:	104 kg
Shipping volume:	1.24 m <sup>3</sup>
Depth with doors open:	1110 mm

### Refrigeration Data

Control type:	Digital
Compressor power:	0.25 hp
Refrigerant type:	R290
GWP Index:	
Refrigeration power:	358 W
Refrigeration power at evaporation temperature:	0 °C
Refrigerant weight:	50 g
Min/Max internal humidity:	40/85
Operating temperature min.:	-2 °C
Operating temperature max.:	10 °C
Operating mode:	Ventilated

### Product Information (EU Regulation 2015/1094)

Energy Class:	A
Yearly and daily energy consumption:	525kWh/year - 1.44kWh/24h
Climate class:	Normal duty (cl.4)
Energy Efficiency Index (EEI):	24,07

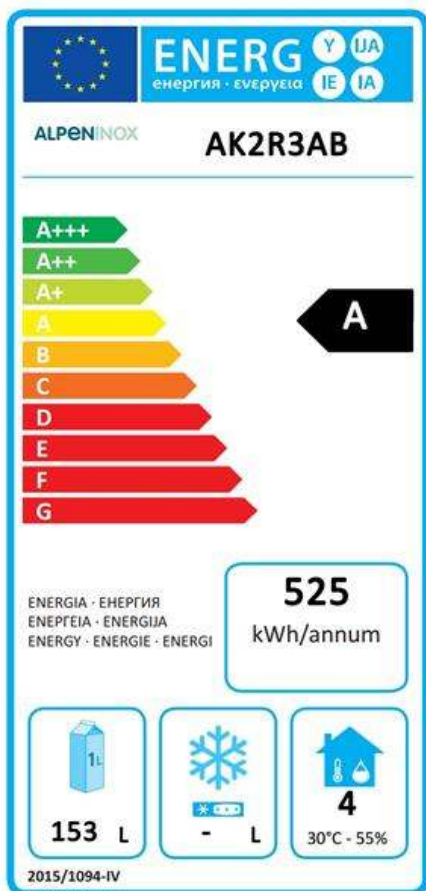

### EU energy labelling from 1st July 2016

The European energy labelling scheme for professional refrigerators and freezers is based on requirements setting Minimum Energy Performance standards for commercial refrigeration cabinets sold within the EU. These requirements are designed to drive energy efficiency and environmentally friendly approach for professionals. The European energy labelling scheme will apply to all manufacturers and importers who sell and market products within the EU and it is mandatory across Europe.

Important: all products which consume energy above the minimum level will not be able to be sold within the EU from 1 July 2016.