

## CRIO Line CP 1 Door and 1/3+2/3 Drawer Refrigerated Counter, 420lt - No Top (R290)

ITEM # \_\_\_\_\_

MODEL # \_\_\_\_\_

NAME # \_\_\_\_\_

SIS # \_\_\_\_\_

AIA # \_\_\_\_\_



721139 (AA3R7AAD)

2-door and 2-drawer (1/3+2/3) refrigerated counter, -2+10°C, AISI 304, without worktop (R290)

### Short Form Specification

#### Item No.

Internal and external doors, front and side panels in 304 AISI stainless steel. No worktop. N.2 doors and n.3x1/3 drawers. Built.in refrigeration unit. Ventilated. Refrigerant R290. Extra insulation: 90mm body insulation to minimize energy dispersion. Digital control panel. Evaporator in aluminium. Completely automatic defrosting and automatic evaporation of defrost water obtained by hot gas. Temperature range: -2+10°C. CFC and HCFC free. Feet in 304 AISI stainless steel, adjustable in height. Pre-arranged for drain pipe.

### Main Features

- IQ Defrost - fully automatic defrost starts only when ice is actually building-up in the evaporator and adapts the defrosting duration to guarantee perfect ice removal while optimizing energy efficiency consumption.
- Large digital white-digit display with humidity selection button (3 preset level), internal temperature display and setting, manual activation of defrost cycle and turbo frost cycle (to rapidly cool warm loads).
- Equipped with Airflow system: forced air circulation system for rapid cooling and even temperature distribution within the cell.
- Tropicalized unit (43°C ambient temperature).
- Fitted with 90 mm thickness of cyclopentane insulation for best insulating performance (thermal conductivity: 0,020 W/m\*K) and lowest environmental impact (GWP=3).
- 0mm clearance installation space: tower configuration cooling unit guarantee performance with frontal ventilation only; this unique solution allows installation against the wall or side by side with other appliances, even on the cooling unit side to maximize the use of kitchen space.
- Combination of doors and drawers to suit any configuration needed, with the possibility to change the configuration on site. Right cooling unit available on request.
- Fully compliant HACCP digital control: when temperature exceeds critical limits, acoustic and visual alarms are activated. Up to two months of event are kept in memory.
- Anti-tilt runners accept GN 1/1 containers.
- Self closing stainless steel doors (< 90°).
- Certified safety CE requirements.
- Prearranged to fit RS485 port to facilitate connection to a remote computer and integrated HACCP systems.
- Adjustable temperature range from -2 °C to +10 °C to suit meat, fish and dairy storage requirements.
- CFC and HCFC free (highly ecological refrigerant type: R290).
- CFC and HCFC free, highly ecological refrigerant type: R290 (ecological gas in foam: cyclopentane). Hydrocarbon refrigerant gas R290 for the lowest environmental impact (GWP=3), to reduce green house and ozone depletion effects.

### Construction

- Extractable cooling unit to facilitate maintenance.
- IP21 protection index.
- Internal dimension of the drawers:
  - models with 2 1/2 drawers: 1st drawer (top drawer) 196x302x521 / 2nd drawer 198x302x521 (HxWxD)
  - models with 3 1/3 drawers: 1st and 2nd drawers (top and central drawer) 99x302x521 / 3rd drawers 103x302x521 (HxWxD)
  - models with 1/3+2/3 drawers: 1st drawer (top

APPROVAL: \_\_\_\_\_

drawer) 99x302x521 / 2nd drawer 295x302x521 (HxWxD)

- Fault code display.
- Interior base with rounded corners, pressed from a single sheet.
- Internal and external doors, front and side panels and removable worktop in AISI 304 Stainless steel.
- Removable triple-chamber balloon magnetic gasket to improve insulation and reduce energy consumption and ease of cleaning.
- Mounted on stainless steel feet to give 150 mm (-5/+50 mm) clearance for ease of cleaning the floor.
- Ease of cleaning and high hygiene standards thanks to the rounded internal corners, the easily removable runners, grids and air conveyors.
- Internal structure with 15 charging positions (3 cm pitch) available to host GN 1/1 grids, ensuring higher net capacity and a greater storage space.
- Developed and produced in ISO 9001 and ISO 14001 certified factory.

### Included Accessories

- 2 of Kit 1/1GN gray rilsan grid and 2 side runners for refrigerated counters PNC 881109

### Optional Accessories

- 1/1GN gray rilsan grid for refrigerated counters PNC 881107
- 2 side runners for 1/1GN refrigerated counters PNC 881108
- Kit 1/1GN gray rilsan grid and 2 side runners for refrigerated counters PNC 881109
- 1/1GN plastic container, h65mm PNC 881110
- 1/1GN plastic container, h100mm PNC 881111
- 1/1GN plastic container, h150mm PNC 881112
- Worktop for refrigerated Crio Line CP and SB counters - 3 compartments PNC 881125
- Worktop and upstand for refrigerated Crio Line CP and SB counters - 3 compartments PNC 881128
- 2-drawer kit refrigerated counters PNC 881179
- 3x1/3-drawer kit for refrigerated counters PNC 881186
- 1/3 and 2/3 bottle drawer kit for refrigerated counters PNC 881187
- Kit 4 wheels, h100mm (2 with brakes) for refrigerated counters PNC 881191
- Kit 4 wheels, h150mm (2 with brakes) for 2&3 compartment refrigerated counters PNC 881193
- Lock for refrigerated counters with three compartments - h650mm PNC 881246

**Front**

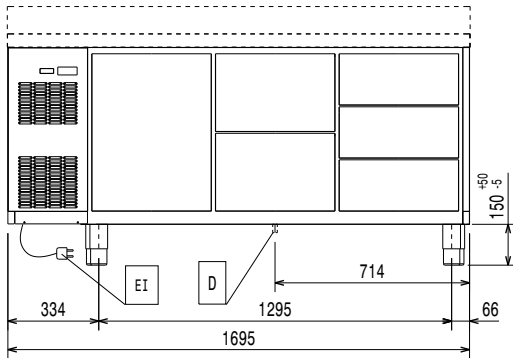

**Side**

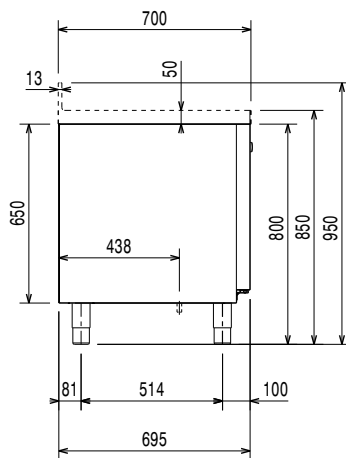

EI = Electrical inlet (power)

**Top**

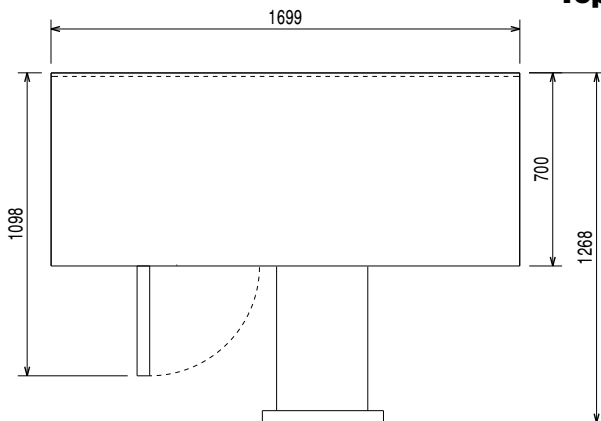

### Electric

Supply voltage:	721139 (AA3R7AAD)	220-240 V/1 ph/50 Hz
Electrical power max.:		0.22 kW
Defrost Power:		0.2 kW
Current consumption:		1.6 Amps
Plug type:		CE-SCHUKO

### Key Information:

Gross capacity:		
Net Volume:		229 lt
Door hinges:		
External dimensions, Width:		1695 mm
External dimensions, Height:		800 mm
External dimensions, Depth:		700 mm
Internal Dimensions (depth):		560 mm
Internal Dimensions (height):		510 mm
Internal Dimensions (width):		1252 mm
Net weight:		112 kg
Shipping volume:		1.36 m <sup>3</sup>
Depth with doors open:		1110 mm
Height adjustment:		0/0 mm

### Refrigeration Data

Control type:		
Compressor power:		0.25 hp
Refrigerant type:		R290
GWP Index:		
Refrigeration power:		358 W
Refrigeration power at evaporation temperature:		0 °C
Refrigerant weight:		65 g
Min/Max internal humidity:		40/85
Operating temperature min.:		-2 °C
Operating temperature max.:		10 °C
Operating mode:		Ventilated

### Product Information (EU Regulation 2015/1094)

Energy Class:		B
Yearly and daily energy consumption:		760kWh/year - 2.08kWh/24h
Climate class:		Normal duty (cl.4)
Energy Efficiency Index (EEI):		32,00