

Roll-in 2 Door Refrigerator, 2700lt (+2/+10)

ITEM # _____

MODEL # _____

NAME # _____

SIS # _____

AIA # _____



729179 (EDVP20VR1)

2-door roll-in refrigerator
2700L, +2/+10°C, (R134A),
AISI 304

Short Form Specification

Item No. _____

External and internal in AISI 304 stainless steel. Body insulation thickness 75mm. N. 2 full doors. Built-in refrigeration unit; ventilated operating mode; digital control; evaporator; automatic defrost; external digital temperature display. Operating temperature +2/+10°C. For ambient temperatures up to 43°C. CFC and HCFC free. R134a gas in refrigeration circuit. Gas in foam: Cyclopentane.

Main Features

- Certified safety CE requirements.
- Two full doors.
- Adjustable temperature range from -2 °C to +10 °C to suit meat, fish and dairy storage requirements.
- The operating temperature can be adjusted from +2 to +10°C to suit both meat and dairy storage requirements.
- Simple control panel: on/off switch, high/low humidity switch and digital temperature display.
- Large digital white-digit display with humidity selection button (3 preset level), internal temperature display and setting, manual activation of defrost cycle and turbo frost cycle (to rapidly cool warm loads).
- Automatic defrost and automatic evaporation of defrost water.
- Equipped with Optiflow forced air circulation system for rapid cooling and temperature distribution within the cell.
- Ventilated cooling for optimal temperature distribution.
- Tropicalized unit (43°C ambient temperature).
- Simple cooling unit easily accessible from the rear of the appliance.
- Fitted with 90 mm thickness of cyclopentane insulation for best insulating performance (thermal conductivity: 0,020 W/m*K) and lowest environmental impact (GWP=3).
- Universal shock-protectors on all sides.
- 0mm clearance installation space: tower configuration cooling unit guarantee performance with frontal ventilation only; this unique solution allows installation against the wall or side by side with other appliances, even on the cooling unit side to maximize the use of kitchen space.
- Frost Watch Control starts automatically the defrosting process only when needed and ends once ice is melted, improving energy efficiency results.
- Combination of doors and drawers to suit any configuration needed, with the possibility to change the configuration on site. Right cooling unit available on request.
- Fully compliant HACCP digital control: when temperature exceeds critical limits, acoustic and visual alarms are activated. Up to two months of event are kept in memory.
- Anti-tilt runners accept GN 1/1 containers.
- Self closing stainless steel doors (< 90°).
- Prearranged to fit RS485 port to facilitate connection to a remote computer and integrated HACCP systems.
- Hydrocarbon refrigerant gas R290 for the lowest environmental impact (GWP=3) - CFC and HCFC free.
- CFC and HCFC free, highly ecological refrigerant type: R290 (ecological gas in foam: cyclopentane). Hydrocarbon refrigerant gas R290 for the lowest environmental impact (GWP=3), to reduce green

APPROVAL: _____

house and ozone depletion effects.

Construction

- Interior base with rounded corners, pressed from a single sheet.
- Ease of cleaning and high hygiene standards thanks to the rounded internal corners, the easily removable runners, grids and air conveyors.
- Internal structure with 15 charging positions (3 cm pitch) available to host GN 1/1 grids, ensuring higher net capacity and a greater storage space.
- Built-in compressor to suit operating conditions.
- Interior cell and external panel are constructed in 304 AISI stainless steel.
- 75 mm thick insulation, with cyclopentane injection for long-term insulation and energy saving.
- CFC and HCFC-free insulation.
- Refrigerant type: R134a.
- Removable triple-chamber balloon magnetic gasket to improve insulation and reduce energy consumption and ease of cleaning.
- Internal structure with numerous charging positions available to host grids, ensuring higher net capacity and a greater storage space.
- Internal and external doors, front and side panels and removable worktop in AISI 304 Stainless steel.
- External bottom panel in stainless steel.
- External back panel in galvanized steel.
- Developed and produced in ISO 9001 and ISO 14001 certified factory.
- Fault code display.

Optional Accessories

- | | |
|--|-------------------------------------|
| • 17x2/1GN container trolley | PNC 361258 <input type="checkbox"/> |
| • 17x2/1GN compact container trolley | PNC 361260 <input type="checkbox"/> |
| • Trolley for 2/1GN roll-in rack | PNC 880017 <input type="checkbox"/> |
| • Base for roll-in-rack | PNC 880018 <input type="checkbox"/> |
| • 2/1GN roll-in rack | PNC 881449 <input type="checkbox"/> |
| • Trolley for 20x2/1GN roll-in rack | PNC 922134 <input type="checkbox"/> |
| • Base for 20x2/1GN roll-in rack | PNC 922142 <input type="checkbox"/> |
| • 60mm pitch roll-in rack for 20x2/1GN | PNC 922204 <input type="checkbox"/> |
| • 80mm pitch roll-in rack for 14x2/1GN | PNC 922206 <input type="checkbox"/> |

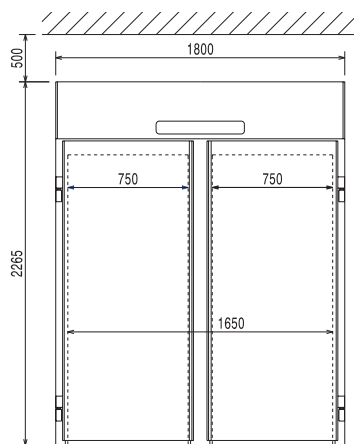

Front

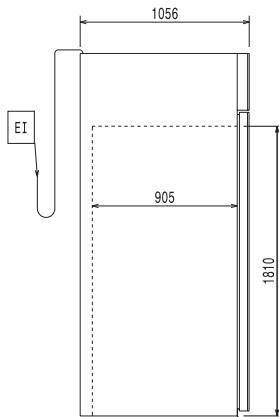

Side

EI = Electrical inlet (power)
RI = Refrigerant Inlet
RO = Refrigerant Outlet

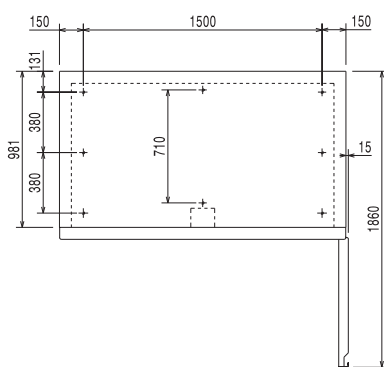

Top

Electric

| | | |
|--|--------------------|------------------|
| Supply voltage: | 729179 (EDVP20VR1) | 230 V/1 ph/50 Hz |
| Electrical power max.: | | 0.95 kW |
| Defrost Power: | | 1.2 kW |
| Current consumption: | | 7.3 Amps |
| Plug type: | | CE-SCHUKO |
| Energy consumption (min,default): | | 0 - 0 kW/h |

Key Information:

| | |
|---|---------------------|
| Gross capacity: | 2700 lt |
| Net Volume: | |
| Door hinges: | |
| External dimensions, Width: | 1800 mm |
| External dimensions, Height: | 2265 mm |
| External dimensions, Depth: | 1056 mm |
| Number and type of doors: | 2 Full |
| Internal Dimensions (depth): | 900 mm |
| Internal Dimensions (height): | 1815 mm |
| Internal Dimensions (width): | 1650 mm |
| Net weight: | 350 kg |
| Shipping volume: | 5.26 m ³ |
| Height adjustment: | 0/0 mm |
| Number and type of grids (included): | |

Refrigeration Data

| | |
|--|------------|
| Control type: | Digital |
| Compressor power: | 1 hp |
| Refrigerant type: | R134a |
| GWP Index: | 1430 |
| Refrigeration power: | 1104 W |
| Refrigeration power at evaporation temperature: | -10 °C |
| Refrigerant weight: | 460 g |
| Min/Max internal humidity: | 75/90 |
| Operating temperature min.: | 2 °C |
| Operating temperature max.: | 10 °C |
| Operating mode: | Ventilated |

Product Information (EU Regulation 2015/1094)

Energy Class:
Yearly and daily energy consumption:
Climate class:
Energy Efficiency Index (EEI):