

## EMPower Smooth Scratch Resistant Chrome Gas Griddle Top 36"

ITEM # \_\_\_\_\_  
 MODEL # \_\_\_\_\_  
 NAME # \_\_\_\_\_  
 SIS # \_\_\_\_\_  
 AIA # \_\_\_\_\_



169183 (ARG36FLCH)

EM Series Restaurant Range griddle, gas, 36" wide, smooth scratch resistant chromium surface with 4" adjustable, removable legs 78,000 BTU

### Short Form Specification

#### Item No. \_\_\_\_\_

Unit to be Electrolux Smooth Chrome Gas Griddle Top with three high efficiency 26,000 BTU (7,6 kW) burners. Suitable for natural gas or propane gas. Thick 1" (25 mm) griddle plate maintains selected temperatures and assures quick recovery. Chromium-plated 3,2" (81,5 mm) wide drainage channel running on full length of cooking surface. Large grease drainage hole diameter 2,4" (60mm). Two half gal. (2 l) grease collector drawers with hole to indicate when full, capture all excess grease and oil and can be extracted for easy dumping and cleaning. Worktop in AISI 304 Stainless Steel. 3mm stainless steel splashback. Front and side panels in Stainless Steel with Scotch Brite finish. All major components can be accessed from front of the appliance for ease of maintenance. Special heavy duty chrome plated knobs for durability and easy cleaning. The configuration of bezels and knobs provides high level of protection against water infiltrations. Right-angled side edges to allow flush fitting joints between units. Supplied with 4" (102mm) height adjustable, removable legs. Unit may be installed on refrigerated base or open cupboard.

### Main Features

- In compliance with ETL Certification (UL & NSF).
- Thick 1" (25 mm) griddle plate maintains selected temperatures and assures quick recovery.
- Three high efficiency 26,000 BTU (7,6 kW) burners.
- Suitable for natural gas or propane gas.
- Flame failure device to protect against accidental extinguishing of the flame.
- 3" (81.5 mm) wide drainage channel running on full length of cooking surface.
- Two large grease drainage holes diameter 2 ½" (60mm).
- Two full length, half gal. (2 l) grease collector drawers with hole to indicate when full, captures all excess grease and oil and can be extracted for easy dumping and cleaning.
- 0.12" (3mm) stainless steel splashback.
- Front and side panels in Stainless Steel with Scotch Brite finish.
- All major compartments located in front of unit for ease of maintenance.
- Special heavy duty chrome plated knobs for durability and easy cleaning.
- The configuration of bezels and knobs provides high level of protection against water infiltrations.
- Right-angled side edges to allow flush fitting joints between units, eliminating gaps and possible dirt traps.
- Provided with kit for side-by-side connection between units for minimizing gaps and possible dirt traps.
- Supplied with 4" (102mm) height adjustable, removable legs.
- Unit may be installed on refrigerated base by removing the legs and inserting the special pins (optional accessory).
- Unit may be installed on open cupboard by removing the legs and inserting the screws provided as standard with the open cupboards.
- Included Accessories: propane converter kit, pressure regulator and main shut off valve.
- Scratch resistant cooking surface thanks to a special treatment of the chromium plate.
- Easy to clean and corrosion resistant chromium surface.

### Construction

- 4 screws to install on the cupboard base are supplied with the unit.
- Gas pressure regulator is supplied with the unit.
- Worktop in 304 AISI stainless steel.
- Cooking surface in scratch resistant chromium-plated steel with non-stick finishing for optimum grilling results.
- Cooking surface 1" (25 mm) thick coated steel for optimum grilling results and ease of use.

### Included Accessories

- 1 of Scraper for smooth griddle PNC 164255

APPROVAL: \_\_\_\_\_

Front

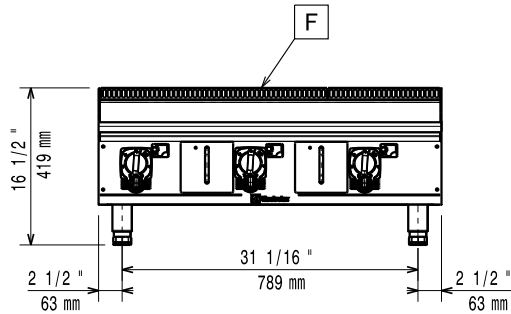

Side

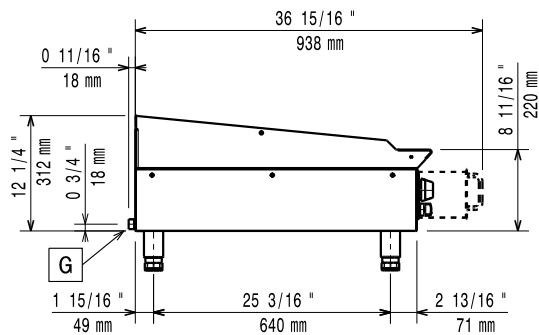

Top

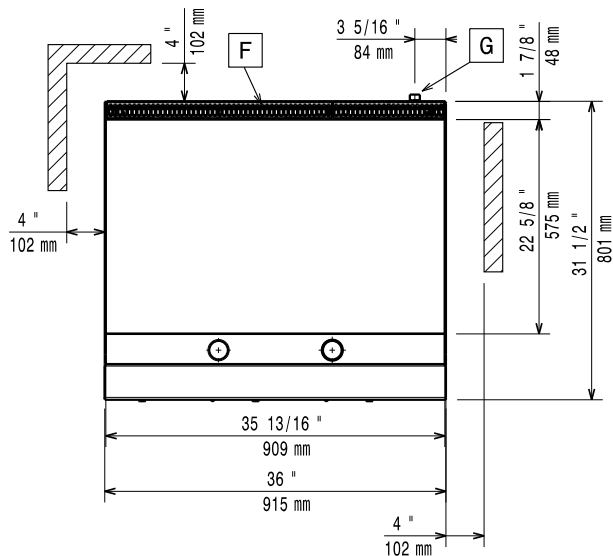

**EQ** = Equipotential screw  
**G** = Gas connection

### Gas

**Gas Power:** 78000 Btu/hr (22.8 kW)  
**Gas Inlet:** 3/4"

### Key Information:

\*The rear and side clearances shown on the diagram indicate the minimum distances recommended from the appliance to combustible surfaces.

**External dimensions, Width:** 36 1/32" (915 mm)  
**External dimensions, Depth:** 31 1/2" (800 mm)  
**External dimensions, Height:** 16 1/2" (419 mm)  
**Net weight:** 317 lbs (144 kg)  
**Shipping width:** 36 1/4" (920 mm)  
**Shipping depth:** 38 9/16" (980 mm)  
**Shipping height:** 26 3/4" (680 mm)  
**Shipping weight:** 373 lbs (169 kg)  
**Shipping volume:** 21.65 ft<sup>3</sup> (0.61 m<sup>3</sup>)