

SkyLine ProS

Electric Boilerless Combi Oven 101 208V

ITEM # _____

MODEL # _____

NAME # _____

SIS # _____

AIA # _____



219652 (ECOIE101K3L0)

SKYLINE ProS OVEN 10
 HALF SHEET PANS (13" X
 18") OR 10 HOTEL PANS (12
 " X 20") TOUCH-ELECTRIC
 208V -BOILERLESS

Short Form Specification

Item No. _____

- Combi oven with high resolution full touch screen interface, multilanguage, IPX5, ETL, EnergyStar, Ergocert
- BOILERLESS
 - OptiFlow: air distribution system with 7 fan speed levels
 - SkyClean: Automatic and built-in self cleaning system with integrated descale of the steam generator.
 - 2 Cooking modes: Programs, Manual
 - Special functions: MultiTimer cooking, Plan-n-Save, SkyHub homepage, agenda MyPlanner, automatic backup mode to avoid downtime
 - USB port to download HACCP data, programs and settings. Connectivity to the cloud ready
 - 6-point multi sensor core temperature probe
 - Triple-glass door with double LED lights line
 - Includes (5) 922062 stainless steel grids

Main Features

- Instant steam generator: Boilerless steaming function to add and retain moisture for high quality, consistent cooking results. Automatic moistener (11 settings)
- Dry, hot convection cycle (77 °F - 575 °F/25°C - 300 °C): ideal for convection cooking.
- EcoDelta cooking: cooking with food probe maintaining preset temperature difference between the core of the food and the cooking chamber.
- Programs mode: a maximum of 1000 recipes can be stored in the oven's memory, to recreate the exact same recipe at any time. The recipes can be group in 16 different categories to better organize the menu. 16-step cooking programs also available.
- MultiTimer: Special feature to manage up to 20 different cooking cycles at the same time in the same cavity guaranteeing even cooking results. Up to 200 MultiTimer available programs
- Reversible Fan: 7 speed fan levels from 300 to 1500 RPM with reverse rotation for optimal evenness. Fan stops in less than 5 seconds when door is opened.
- Automatic cool-down and pre-heat function
- Different chemical options available: solid (phosphate-free), liquid (requires optional accessory).
- GreaseOut: predisposed for integrated grease drain and collection for safer operations (dedicated base as optional accessory).
- Back-up mode: self-diagnosis is automatically activated if a failure occurs to avoid downtime.
- 6-point multi sensor core temperature probe for maximum precision and food safety.
- Capacity: 10 half sheet/hotel pans.
- OptiFlow air distribution system to achieve maximum performance in chilling/heating evenness and temperature control thanks to a special design of the chamber.

Construction

- Seamless hygienic internal chamber with all rounded corners for easy cleaning.
- 304 AISI stainless steel construction throughout.
- Front access to control board for easy service.
- IPX 5 spray water protection certification for easy cleaning.
- Supplied with 6 tray rack for hotel pans, 2 2/3" pitch (67 mm).
- Triple thermo-glazed door: with 2 hinged inside panels for easy cleaning and double LED lights line.

User Interface & Data Management

- Touchscreen: High resolution interface (translated into more than 30 languages including Spanish and French) - color-blind friendly panel.
- Picture Management: upload full customized images of cooking cycles or food items
- Make-it-mine: feature to allow full personalization or locking of the user interface by selecting what is visible on screen

APPROVAL: _____



- SkyHub: customizable homepage to allow the user to group their favorite functions for immediate access when operating.
- MyPlanner: on-screen agenda where the user can plan their daily work, set reminders for several users and receive personalized alerts for each activity
- USB port: to download HACCP data, share cooking programs and configurations. USB port also allows to plug-in sous-vide probe (optional accessory).
- Connectivity: ready for real time access to connected appliances from remote and HACCP monitoring (requires optional accessory).
- e-learning: equipment trainings, how-to guides, and technical documentation easily accessible by scanning QR-Code with any mobile device.
- Data Analytics: automatic consumption visualization at the end of the cycle.

Sustainability



- Human centered design: with 4-star certification for ergonomics and usability.
- Door handle: ergonomic wing-shaped design for hands-free door opening with elbow, to allow simple trays management (Registered Design at EPO).
- Reduced-Power Feature: To consume less energy during customized slow cooking cycles.
- SkyClean: Automatic self cleaning system with integrated descaling of the steam boiler. 5 automatic cycles (soft, medium, strong, extra strong, rinse-only) and green functions to save energy, water, detergent and rinse aid. Also programmable with delayed start.
- Plan-n-Save: the oven organizes the sequence of the chosen cooking cycles to optimize the processes in the kitchen reducing time and energy consumption.

Included Accessories

- 5 of Single 304 stainless steel grid (12" x 20") PNC 922062

Optional Accessories

Front

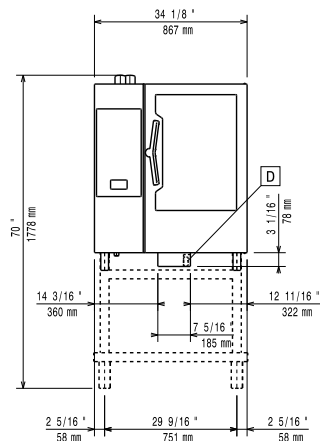

Side

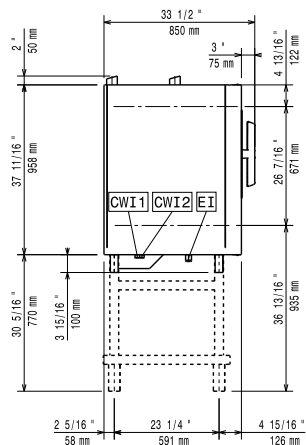

CWI1 = Cold Water inlet EI = Electrical connection

CWI2 = Cold Water Inlet 2

D = Drain

DO = Overflow drain pipe

Top

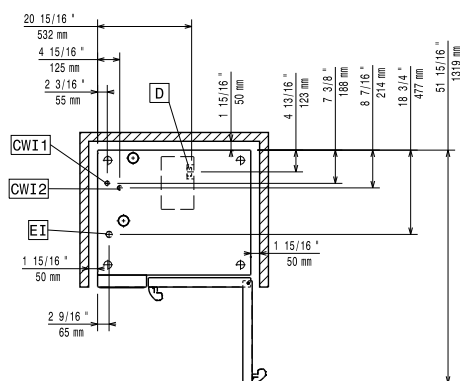

Electric

Supply voltage:	208 V/3 ph/60 Hz
Electrical power, max:	19 kW
Electrical power, default:	19 kW

Water:

Water Cold Supply

Connection:	219652 (ECO101K3L0)	3/4"
Cold Water Inlet Connection:		3/4" GHT
Drain "D":		2" (50 mm)

Max inlet water supply temperature:	86°F (30°C)
Water inlet cold 1:	unfiltered
Water inlet cold 2:	filtered

Electrolux Professional recommends the use of treated water, based on testing of specific water conditions. Refer to manual for details

Pressure:	15-87 psi (1-6 bar)
Chlorides:	<10 ppm
Conductivity:	>50 µS/cm

Installation:

Clearance:	Clearance: 2 in (5 cm) rear and right hand sides.
Suggested clearance for service access:	20 in (50 cm) left hand side.

Capacity:

Max load capacity:	110 lbs (50 kg)
Hotel pans:	10 - 12" X 20"
Half-size sheet pans:	10 - 13" X 18"

Key Information:

Door hinges:	Right Side
External dimensions, Width:	34 1/8" (867 mm)
External dimensions, Depth:	30 1/2" (775 mm)
External dimensions, Height:	41 5/8" (1058 mm)
Net weight:	290 lbs (131.5 kg)
Shipping width:	36 5/8" (930 mm)
Shipping depth:	36 5/8" (930 mm)
Shipping height:	50 3/8" (1280 mm)
Shipping weight:	330 lbs (149.5 kg)
Shipping volume:	39.09 ft ³ (1.11 m ³)

ISO Certificates

ISO Standards:	ISO 9001; ISO 14001; ISO 45001; ISO 50001
----------------	---

Sustainability

Current consumption:	52.9 Amps
----------------------	-----------