

## SkyLine ProS Natural Gas Boilerless Combi Oven 62 120V

ITEM # \_\_\_\_\_  
 MODEL # \_\_\_\_\_  
 NAME # \_\_\_\_\_  
 SIS # \_\_\_\_\_  
 AIA # \_\_\_\_\_

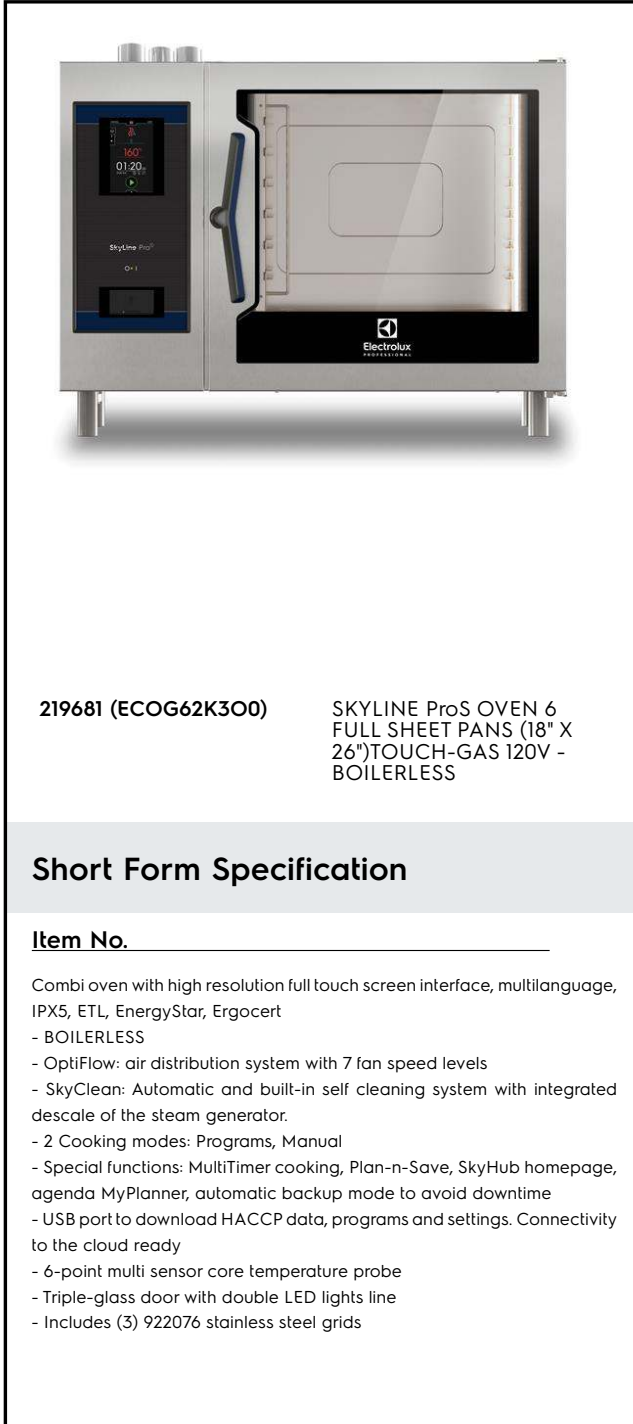

### Short Form Specification

**Item No.** \_\_\_\_\_

- Combi oven with high resolution full touch screen interface, multilanguage, IPX5, ETL, EnergyStar, Ergocert
- BOILERLESS
  - OptiFlow: air distribution system with 7 fan speed levels
  - SkyClean: Automatic and built-in self cleaning system with integrated descale of the steam generator.
  - 2 Cooking modes: Programs, Manual
  - Special functions: MultiTimer cooking, Plan-n-Save, SkyHub homepage, agenda MyPlanner, automatic backup mode to avoid downtime
  - USB port to download HACCP data, programs and settings. Connectivity to the cloud ready
  - 6-point multi sensor core temperature probe
  - Triple-glass door with double LED lights line
  - Includes (3) 922076 stainless steel grids

### Main Features

- 6-point multi sensor core temperature probe for maximum precision and food safety.
- Capacity: 6 full sheet pans or 12 half sheet/hotel pans.
- Instant steam generator: Boilerless steaming function to add and retain moisture for high quality, consistent cooking results. Automatic moistener (11 settings)
- Dry, hot convection cycle (77 °F - 575 °F/25°C - 300 °C): ideal for convection cooking.
- EcoDelta cooking: cooking with food probe maintaining preset temperature difference between the core of the food and the cooking chamber.
- Programs mode: a maximum of 1000 recipes can be stored in the oven's memory, to recreate the exact same recipe at any time. The recipes can be group in 16 different categories to better organize the menu. 16-step cooking programs also available.
- MultiTimer: Special feature to manage up to 20 different cooking cycles at the same time in the same cavity guaranteeing even cooking results. Up to 200 MultiTimer available programs
- Reversible Fan: 7 speed fan levels from 300 to 1500 RPM with reverse rotation for optimal evenness. Fan stops in less than 5 seconds when door is opened.
- Automatic cool-down and pre-heat function
- Different chemical options available: solid (phosphate-free), liquid (requires optional accessory).
- GreaseOut: predisposed for integrated grease drain and collection for safer operations (dedicated base as optional accessory).
- Back-up mode: self-diagnosis is automatically activated if a failure occurs to avoid downtime.
- OptiFlow air distribution system to achieve maximum performance in chilling/heating evenness and temperature control thanks to a special design of the chamber.

### Construction

- Triple thermo-glazed door: with 2 hinged inside panels for easy cleaning and double LED lights line.
- Seamless hygienic internal chamber with all rounded corners for easy cleaning.
- 304 AISI stainless steel construction throughout.
- Front access to control board for easy service.
- IPX 5 spray water protection certification for easy cleaning.
- Supplied with 6 tray rack for full size pans, 2 2/3" pitch.

### User Interface & Data Management

- Touchscreen: High resolution interface (translated into more than 30 languages including Spanish and French) - color-blind friendly panel.
- Picture Management: upload full customized images of cooking cycles or food items
- Make-it-mine: feature to allow full personalization or locking of the user interface by selecting what is visible on screen
- SkyHub: customizable homepage to allow the user to

**APPROVAL:** \_\_\_\_\_



group their favorite functions for immediate access when operating.

- MyPlanner: on-screen agenda where the user can plan their daily work, set reminders for several users and receive personalized alerts for each activity
- USB port: to download HACCP data, share cooking programs and configurations. USB port also allows to plug-in sous-vide probe (optional accessory).
- Connectivity: ready for real time access to connected appliances from remote and HACCP monitoring (requires optional accessory).
- e-learning: equipment trainings, how-to guides, and technical documentation easily accessible by scanning QR-Code with any mobile device.
- Data Analytics: automatic consumption visualization at the end of the cycle.

### Sustainability



- Human centered design: with 4-star certification for ergonomics and usability.
- Door handle: ergonomic wing-shaped design for hands-free door opening with elbow, to allow simple trays management (Registered Design at EPO).
- Reduced-Power Feature: To consume less energy during customized slow cooking cycles.
- SkyClean: Automatic self cleaning system with integrated descaling of the steam boiler. 5 automatic cycles (soft, medium, strong, extra strong, rinse-only) and green functions to save energy, water, detergent and rinse aid. Also programmable with delayed start.
- Plan-n-Save: the oven organizes the sequence of the chosen cooking cycles to optimize the processes in the kitchen reducing time and energy consumption.

### Included Accessories

- 3 of Aisi 304 stainless steel PNC 922076 grid (18" x 26")

### Optional Accessories

Front

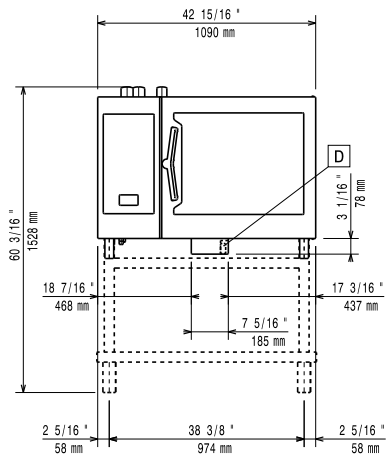

Side

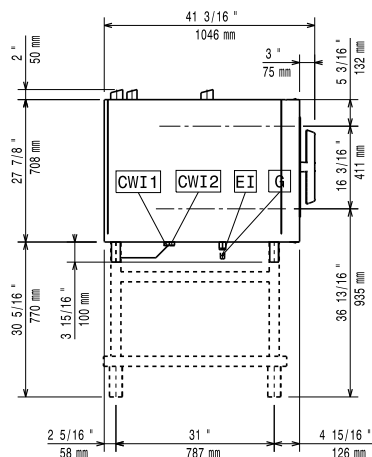

CWI1 = Cold Water inlet      EI = Electrical connection

CWI2 = Cold Water Inlet 2      G = Gas connection

D = Drain

DO = Overflow drain pipe

Top

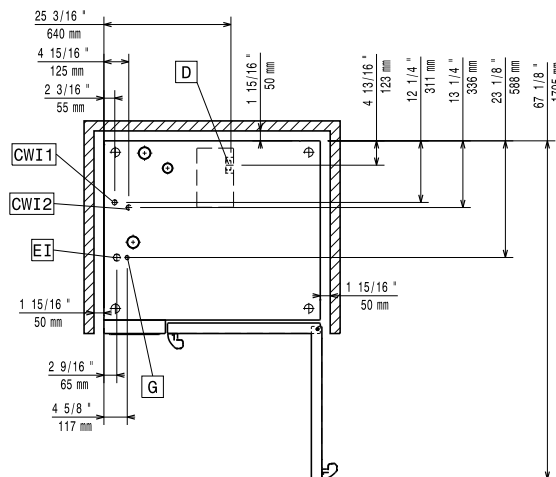

### Electric

Supply voltage:	120 V/1 ph/60 Hz
Electrical power, max:	1.5 kW
Electrical power, default:	1.5 kW

### Gas

Static Pressure:	< 10" WC
Dynamic Pressure:	7" WC

Electrolux Professional does not recommend the use of a GFCI outlet. If a GFCI outlet is required by code, a commercial GFCI with a trip rating of 20 mA must be used.

Gas Power:	28.3 kW
Standard gas delivery:	Natural Gas G20
ISO 7/1 gas connection diameter:	1/2" MNPT

### Water:

Water Cold Supply Connection:	3/4"
Cold Water Inlet Connection:	3/4" GHT
Drain "D":	2" (50 mm)
Max inlet water supply temperature:	86°F (30°C)
Water inlet cold 1:	unfiltered
Water inlet cold 2:	filtered

Electrolux Professional recommends the use of treated water, based on testing of specific water conditions. Refer to manual for details

Pressure:	15-87 psi (1-6 bar)
Chlorides:	<10 ppm
Conductivity:	0 µS/cm

### Installation:

Clearance:	Clearance: 2 in (5 cm) rear and right hand sides.
Suggested clearance for service access:	20 in (50 cm) left hand side.

### Capacity:

Max load capacity:	132 lbs (60 kg)
Full-size sheet pans:	6 - 18" X 26"

### Key Information:

Door hinges:	Right Side
External dimensions, Width:	42 15/16" (1090 mm)
External dimensions, Depth:	38 1/4" (971 mm)
External dimensions, Height:	31 13/16" (808 mm)
Net weight:	367 lbs (166.5 kg)
Shipping width:	44 1/2" (1130 mm)
Shipping depth:	43 5/16" (1100 mm)
Shipping height:	40 9/16" (1030 mm)
Shipping weight:	418 lbs (189.5 kg)
Shipping volume:	45.21 ft³ (1.28 m³)

### ISO Certificates

