

SkyLine Pro Electric Combi Oven 10GN1/1, 230V

ITEM # _____

MODEL # _____

NAME # _____

SIS # _____

AIA # _____

217908 (ECOE101C3C30)

 SkyLine Pro Combi Boilerless
 Oven with digital control,
 10x1/1GN, electric,
 programmable, automatic
 cleaning, 3-glass door -
 230V

Short Form Specification

Item No.

Combi oven with digital interface with guided selection.

- Boilerless steaming function to add and retain moisture.
- OptiFlow air distribution system to achieve maximum performance with 5 fan speed levels.
- SkyClean: Automatic and built-in self cleaning system. 4 automatic cycles (short, medium, intensive, rinse).
- Cooking modes: Programs (a maximum of 100 recipes can be stored); Manual; EcoDelta cooking cycle.
- Automatic backup mode to avoid downtime.
- USB port to download HACCP data, programs and settings
- Connectivity for real time access, remote software update, HACCP, recipe and energy management (optional)
- Single sensor core temperature probe.
- Triple-glass door with double LED lights line.
- Stainless steel construction throughout.
- Supplied with n.1 tray rack 1/1 GN, 67 mm pitch.

Main Features

- Single sensor core temperature probe included.
- SkyClean: Automatic and built-in self cleaning system with 4 automatic cycles (short, medium, intensive, rinse).
- Boilerless steaming function to add and retain moisture for high quality, consistent cooking results.
- Dry hot convection cycle (max 300 °C) ideal for low humidity cooking. Automatic moistener (11 settings) for boiler-less steam generation.
- Short cleaning cycle: optimized cleaning cycle with a duration of just 33 minutes, improving efficiency and reducing downtime.
- 6-point multi sensor core temperature probe for maximum precision and food safety (optional accessory).
- EcoDelta cooking: cooking with food probe maintaining preset temperature difference between the core of the food and the cooking chamber.
- Programs mode: a maximum of 100 recipes can be stored in the oven's memory, to recreate the exact same recipe at any time. 4-step cooking programs also available.
- OptiFlow air distribution system to achieve maximum performance in chilling/heating evenness and temperature control thanks to a special design of the chamber.
- Fan with 5 speed levels from 300 to 1500 RPM and reverse rotation for optimal evenness. Fan stops in less than 5 seconds when door is opened.
- Automatic fast cool down and pre-heat function.
- Back-up mode with self-diagnosis is automatically activated if a failure occurs to avoid downtime.
- Electrolux Professional recommends the use of treated water to guarantee optimal cooking results and extend the life of the appliance. Check local water condition to select the appropriate water filter. More info available on the website.

Construction

- Triple thermo-glazed door with 2 hinged inside panels for easy cleaning and double LED lights line.
- Hygienic internal chamber with all rounded corners for easy cleaning.
- 304 AISI stainless steel construction throughout.
- Front access to control board for easy service.
- IPX5 spray water protection certification for easy cleaning.

User Interface & Data Management

- Connectivity for remote real time access, easy HACCP management, equipment uptime increase, consumption tracking and energy management (requires optional accessory).
- Digital interface with LED backlight buttons with guided selection.
- USB port to download HACCP data, share cooking programs and configurations. USB port also allows to plug-in sous-vide probe (optional accessory).

Sustainability



APPROVAL: _____

- Human centered design with 4-star certification for ergonomics and usability.
- Wing-shaped handle with ergonomic design and hands-free opening with the elbow, making managing trays simpler. Protected by registered design (EM003143551 and related family).
- The outer cardboard packaging is made from 70% recycled materials and FSC⁺-certified paper, printed with eco-friendly, water-based ink to support sustainability and environmental responsibility.

<i>(*Forest Stewardship Council is the world's leading organization for sustainable forest management).</i>

- Triple-glass door minimize your energy loss.*

*<i>Approx. -10% of idle energy consumption in convection based on test in compliance with ASTM Standard F2861-20</i>

- Uses 33% less water and 22% less detergent while cleaning, as compared to previous model.
- Save energy, water, detergent and rinse aid with SkyClean green functions.
- C22 and C25 detergents are formulated without phosphates and phosphorus (C25 is also maleic acid-free), making them safe for both the environment and human health.

Optional Accessories

- Water filter with cartridge and flow meter for low steam usage (less than 2 hours of full steam per day) PNC 920004
- Water filter with cartridge and flow meter for medium steam usage PNC 920005
- Wheel kit for 6 & 10 GN 1/1 and 2/1 GN oven base (not for the disassembled one) PNC 922003
- Pair of AISI 304 stainless steel grids, GN 1/1 PNC 922017
- Pair of grids for whole chicken (8 per grid - 1,2kg each), GN 1/1 PNC 922036
- AISI 304 stainless steel grid, GN 1/1 PNC 922062
- Grid for whole chicken (4 per grid - 1,2kg each), GN 1/2 PNC 922086
- External side spray unit (needs to be mounted outside and includes support to be mounted on the oven) PNC 922171
- Baking tray for 5 baguettes in perforated aluminum with silicon coating, 400x600x38mm PNC 922189
- Baking tray with 4 edges in perforated aluminum, 400x600x20mm PNC 922190
- Baking tray with 4 edges in aluminum, 400x600x20mm PNC 922191
- Pair of frying baskets PNC 922239
- AISI 304 stainless steel bakery/pastry grid 400x600mm PNC 922264
- Double-step door opening kit PNC 922265
- Grid for whole chicken (8 per grid - 1,2kg each), GN 1/1 PNC 922266
- Grease collection tray, GN 1/1, H=100 mm PNC 922321
- Kit universal skewer rack and 4 long skewers for Lenghtwise ovens PNC 922324
- Universal skewer rack PNC 922326
- 4 long skewers PNC 922327

- Grease collection tray, GN 1/1, H=40 mm PNC 922329
- Multipurpose hook PNC 922348
- 4 flanged feet for 6 & 10 GN , 2", 100-130mm PNC 922351
- Grid for whole duck (8 per grid - 1,8kg each), GN 1/1 PNC 922362
- Thermal cover for 10 GN 1/1 oven and blast chiller freezer PNC 922364
- Tray support for 6 & 10 GN 1/1 disassembled open base PNC 922382
- Wall mounted detergent tank holder PNC 922386
- USB single point probe PNC 922390
- 4 service feet for 6 & 10 GN Oven, 100mm - Marine PNC 922394
- IoT module for OnE Connected (Combi Ovens, Blast chiller/freezers, Rack Type DW) and SkyDuo (one IoT board per appliance - to connect oven to blast chiller for Cook&Chill process). PNC 922421
- Connectivity router (WiFi and LAN) PNC 922435
- Steam optimizer PNC 922440
- Grease collection kit for GN 1/1-2/1 cupboard base (trolley with 2 tanks, open/close device for drain) PNC 922450
- Grease collection kit for GN 1/1-2/1 open base (2 tanks, open/close device for drain) PNC 922451
- Grease collection kit for ovens GN 1/1 & 2/1 (2 plastic tanks, connection valve with pipe for drain) PNC 922452
- Tray rack with wheels 10 GN 1/1, 65mm pitch PNC 922601
- Tray rack with wheels, 8 GN 1/1, 80mm pitch PNC 922602
- Bakery/pastry tray rack with wheels holding 400x600mm grids for 10 GN 1/1 oven and blast chiller freezer, 80mm pitch (8 runners) PNC 922608
- Slide-in rack with handle for 6 & 10 GN 1/1 oven PNC 922610
- Open base with tray support for 6 & 10 GN 1/1 oven PNC 922612
- Cupboard base with tray support for 6 & 10 GN 1/1 oven PNC 922614
- Hot cupboard base with tray support for 6 & 10 GN 1/1 oven holding GN 1/1 or 400x600mm trays PNC 922615
- External connection kit for liquid detergent and rinse aid PNC 922618
- Stacking kit for 6+6 GN 1/1 ovens on electric 6+10 GN 1/1 GN ovens PNC 922620
- Trolley for slide-in rack for 6 & 10 GN 1/1 oven and blast chiller freezer PNC 922626
- Trolley for mobile rack for 6 GN 1/1 on 6 or 10 GN 1/1 ovens PNC 922630
- Stainless steel drain kit for 6 & 10 GN oven, dia=50mm PNC 922636
- Plastic drain kit for 6 & 10 GN oven, dia=50mm PNC 922637
- Wall support for 10 GN 1/1 oven PNC 922645
- Banquet rack with wheels holding 30 plates for 10 GN 1/1 oven and blast chiller freezer, 65mm pitch PNC 922648

• Banquet rack with wheels 23 plates for 10 GN 1/1 oven and blast chiller freezer, 85mm pitch	PNC 922649	<input type="checkbox"/>	• Kit for installation of electric power peak management system for 6 & 10 GN Oven	PNC 922774	<input type="checkbox"/>
• Dehydration tray, GN 1/1, H=20mm	PNC 922651	<input type="checkbox"/>	• Extension for condensation tube, 37cm	PNC 922776	<input type="checkbox"/>
• Flat dehydration tray, GN 1/1	PNC 922652	<input type="checkbox"/>	• Non-stick universal pan, GN 1/1, H=20mm	PNC 925000	<input type="checkbox"/>
• Open base for 6 & 10 GN 1/1 oven, disassembled - NO accessory can be fitted with the exception of 922382	PNC 922653	<input type="checkbox"/>	• Non-stick universal pan, GN 1/1, H=40mm	PNC 925001	<input type="checkbox"/>
• Bakery/pastry rack kit for 10 GN 1/1 oven with 8 racks 400x600mm and 80mm pitch	PNC 922656	<input type="checkbox"/>	• Non-stick universal pan, GN 1/1, H=60mm	PNC 925002	<input type="checkbox"/>
• Heat shield for stacked ovens 6 GN 1/1 on 10 GN 1/1	PNC 922661	<input type="checkbox"/>	• Double-face griddle, one side ribbed and one side smooth, GN 1/1	PNC 925003	<input type="checkbox"/>
• Heat shield for 10 GN 1/1 oven	PNC 922663	<input type="checkbox"/>	• Aluminum grill, GN 1/1	PNC 925004	<input type="checkbox"/>
• Fixed tray rack for 10 GN 1/1 and 400x600mm grids	PNC 922685	<input type="checkbox"/>	• Frying pan for 8 eggs, pancakes, hamburgers, GN 1/1	PNC 925005	<input type="checkbox"/>
• Kit to fix oven to the wall	PNC 922687	<input type="checkbox"/>	• Flat baking tray with 2 edges, GN 1/1	PNC 925006	<input type="checkbox"/>
• Tray support for 6 & 10 GN 1/1 oven base	PNC 922690	<input type="checkbox"/>	• Baking tray for 4 baguettes, GN 1/1	PNC 925007	<input type="checkbox"/>
• 4 adjustable feet with black cover for 6 & 10 GN ovens, 100-115mm	PNC 922693	<input type="checkbox"/>	• Potato baker for 28 potatoes, GN 1/1	PNC 925008	<input type="checkbox"/>
• Reinforced tray rack with wheels, lowest support dedicated to a grease collection tray for 10 GN 1/1 oven, 64mm pitch	PNC 922694	<input type="checkbox"/>	• Non-stick universal pan, GN 1/2, H=20mm	PNC 925009	<input type="checkbox"/>
• Detergent tank holder for open base	PNC 922699	<input type="checkbox"/>	• Non-stick universal pan, GN 1/2, H=40mm	PNC 925010	<input type="checkbox"/>
• Bakery/pastry runners 400x600mm for 6 & 10 GN 1/1 oven base	PNC 922702	<input type="checkbox"/>	• Non-stick universal pan, GN 1/2, H=60mm	PNC 925011	<input type="checkbox"/>
• Wheels for stacked ovens	PNC 922704	<input type="checkbox"/>	• Kit of 6 non-stick universal pans, GN 1/1, H=20mm	PNC 925012	<input type="checkbox"/>
• Spit for lamb or suckling pig (up to 12kg) for GN 1/1 ovens	PNC 922709	<input type="checkbox"/>	• Kit of 6 non-stick universal pans, GN 1/1, H=40mm	PNC 925013	<input type="checkbox"/>
• Mesh grilling grid, GN 1/1	PNC 922713	<input type="checkbox"/>	• Kit of 6 non-stick universal pan GN 1/1, H=60mm	PNC 925014	<input type="checkbox"/>
• Probe holder for liquids	PNC 922714	<input type="checkbox"/>			
• Odour reduction hood with fan for 6 & 10 GN 1/1 electric ovens	PNC 922718	<input type="checkbox"/>	Recommended Detergents		
• Odour reduction hood with fan for 6+6 or 6+10 GN 1/1 electric ovens	PNC 922722	<input type="checkbox"/>	• C25 Rinse & Descale Tabs, phosphate-free, phosphorous-free, maleic acid-free, 50 tabs bucket	PNC 0S2394	<input type="checkbox"/>
• Condensation hood with fan for 6 & 10 GN 1/1 electric oven	PNC 922723	<input type="checkbox"/>	• C22 Cleaning Tabs, phosphate-free, phosphorous-free, 100 bags bucket	PNC 0S2395	<input type="checkbox"/>
• Condensation hood with fan for stacking 6+6 or 6+10 GN 1/1 electric ovens	PNC 922727	<input type="checkbox"/>			
• Exhaust hood with fan for 6 & 10 GN 1/1 ovens	PNC 922728	<input type="checkbox"/>			
• Exhaust hood with fan for stacking 6+6 or 6+10 GN 1/1 ovens	PNC 922732	<input type="checkbox"/>			
• Exhaust hood without fan for 6&10 1/1GN ovens	PNC 922733	<input type="checkbox"/>			
• Exhaust hood without fan for stacking 6+6 or 6+10 GN 1/1 ovens	PNC 922737	<input type="checkbox"/>			
• 4 high adjustable feet for 6 & 10 GN ovens, 230-290mm	PNC 922745	<input type="checkbox"/>			
• Tray for traditional static cooking, H=100mm	PNC 922746	<input type="checkbox"/>			
• Double-face griddle, one side ribbed and one side smooth, 400x600mm	PNC 922747	<input type="checkbox"/>			
• Hood Hopper to directly connect the Hood to the centralized ventilation system, for Standard Hoods (with fan motor) and Hoods without fan motor	PNC 922751	<input type="checkbox"/>			
• Trolley for grease collection kit	PNC 922752	<input type="checkbox"/>			
• Water inlet pressure reducer	PNC 922773	<input type="checkbox"/>			

Front

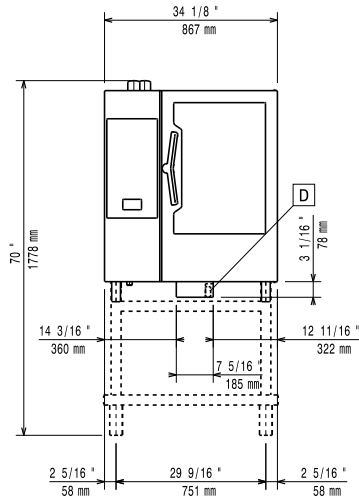

Side

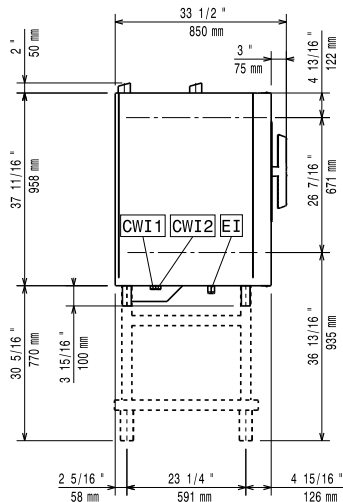

CWI1 = Cold Water inlet 1 (cleaning) EI = Electrical inlet (power)
 CWI2 = Cold Water Inlet 2 (steam generator)
 D = Drain
 DO = Overflow drain pipe

Top

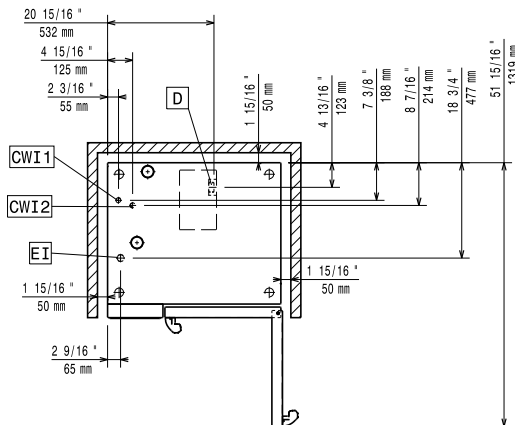

Electric

Default power corresponds to factory test conditions. When supply voltage is declared as a range the test is performed at the average value. According to the country, the installed power may vary within the range.

Circuit breaker required

Supply voltage: 220-240 V/3 ph/50-60 Hz
Electrical power, max: 20.3 kW
Electrical power, default: 19 kW

Water:

Inlet water temperature, max: 30 °C
Inlet water pipe size (CWI1, CWI2): 3/4"
Pressure, min-max: 1-6 bar
Chlorides: <10 ppm
Conductivity: >50 µS/cm
Drain "D": 50mm

Electrolux Professional recommends the use of treated water, based on testing of specific water conditions.

Please refer to user manual for detailed water quality information.

Installation:

Clearance: Clearance: 5 cm rear and right hand sides.
Suggested clearance for service access: 50 cm left hand side.

Capacity:

Trays type: 10 (GN 1/1)
Max load capacity: 50 kg

Key Information:

Door hinges: Right Side
External dimensions, Width: 867 mm
External dimensions, Depth: 775 mm
External dimensions, Height: 1058 mm
Weight: 144 kg
Net weight: 127 kg
Shipping weight: 144 kg
Shipping volume: 1.11 m³

ISO Certificates

ISO Standards: ISO 9001; ISO 14001; ISO 45001; ISO 50001