

Drop-In
Drop-in bain-marie, air ventilated, with
one well (2 GN container capacity) and
A overshelf

ITEM # _____

MODEL # _____

NAME # _____

SIS # _____

AIA # _____

341159 (D03H2O)

Drop-in Bain-marie, air ventilated, with one well (2 GN container capacity) with one A type overshelf predisposed for hot lamps

Short Form Specification

Item No. _____

Suitable for GN 1/1 containers with a maximum height of 150 mm. Designed to serve the food in gastrornorm containers. Well in 304 AISI stainless steel with rounded corners to facilitate cleaning operations. The well is also equipped with a drain hole. 19mm thick rock wool isolated with galvanize sheet guarantees excellent well insulation to reduce energy dispersion. A constant flow of hot air circulating through the containers guarantees the correct food temperatures. Temperature uniformity and fast warm up time are guaranteed thanks to heavy duty armored heating elements and powerful radial booster fans. Cylindrical stainless steel air diffusors provides a constant air circulation. The system operates without water and ensures energy efficiency when compared to standard bain-marie heating. Food introduced at the correct temperature maintains its core temperature according to Afnor Standards. Stylish A type overshelf designed for extra increased visibility on the surface for charming food display. Overshelf equipped with hot halogen lamps (bulbs not included) .

Main Features

- Electronic overheating protection.
- Suitable for GN 1/1 containers with a maximum height of 150 mm.
- Wells in 304 AISI stainless steel with drain holes and pipes and with rounded corners to facilitate cleaning operations.
- CB and CE certified by a third party notified body.
- Designed to serve the food in gastrornorm containers.
- Precise temperature control and setting at 0,1°C .
- As standard the product comes with digitally controlled thermostat which is in line of HACCP norms and provides visual alarm as a warning of the increasing or decreasing temperatures.
- It is possible to transform one of the GNs to soup dispenser with the available accessory.
- A constant flow of hot air circulating through the containers guarantees the correct food temperatures. Temperature uniformity and fast warm up time are guaranteed thanks to heavy duty armored heating elements and powerful radial booster fans. Cylindrical stainless steel air diffusors provides a constant air circulation.
- Since the water is not needed to heat the well, the system guarantees easy of use and maintenance: there is no calcification of the resistances.
- No need extra connections for water, less work during installation/maintenance.
- Food introduced at the correct temperature maintains its core temperature according to Afnor Standards.
- Stylish A type overshelf designed for extra increased visibility on the surface for charming food display.
- Designed to be positioned in flush installation providing improved cleanability and suitable for modern design installations.

Construction

- IPx4 water protection.
- Well in 304 AISI stainless steel with rounded corners to facilitate cleaning operations. The well is also equipped with

APPROVAL: _____

a drain hole.

- Electronic control with temperature display.
- Overshelf in complete AISI 304.
- Overshelf predisposed for halogen lamp bulbs type R7s 118mm 120W.

Sustainability



- 19mm thick rock wool isolated with galvanize sheet guarantees excellent well insulation to reduce energy dispersion.
- 90% fast preheating phase and no need for water (as traditional bain marie), reduces energy and no water consumption.
- The system operates without water and ensures energy efficiency when compared to standard bain-marie heating.
- No water consumption means less operating costs.



Electrolux
PROFESSIONAL

Drop-In
Drop-in bain-marie, air ventilated, with one well (2 GN container capacity) and A overshelf

Front

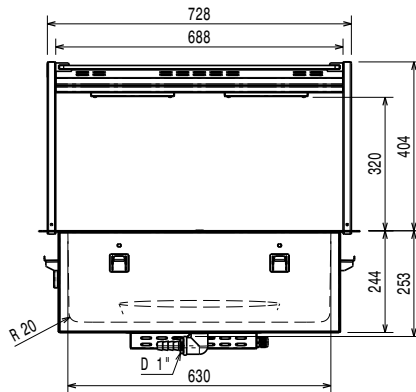

Side

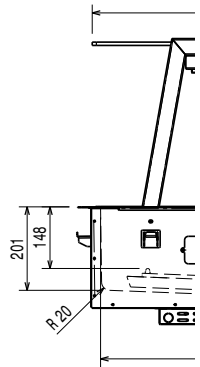

D = Drain
EI = Electrical inlet (power)

Top

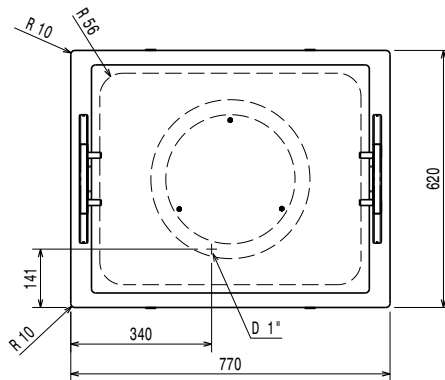

Electric

Supply voltage: 220-240 V/1N ph/50/60 Hz
Electrical power, max: 1.05 kW

Key Information:

External dimensions, Width: 770 mm
External dimensions, Depth: 620 mm
External dimensions, Height: 680 mm
Net weight: 38.96 kg
Shipping weight: 55.96 kg
Shipping height: 1040 mm
Shipping width: 660 mm
Shipping depth: 810 mm
Shipping volume: 0.56 m³
Set temperature: +75 / +85 °C

Sustainability

Noise level: 58,6 dBA



Drop-In
Drop-in bain-marie, air ventilated, with one well (2 GN container capacity) and A overshelf
The company reserves the right to make modifications to the products without prior notice. All information correct at time of printing.

2026.03.09

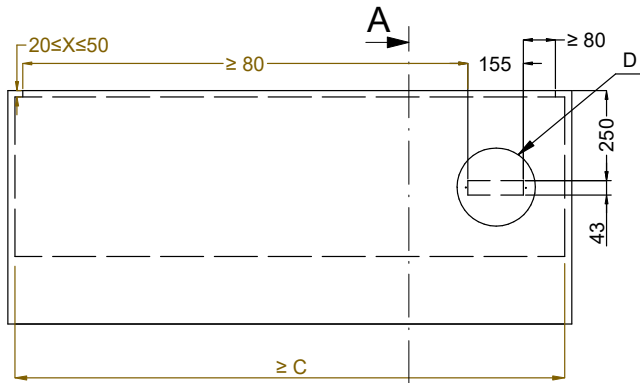

Front view
Scala: 1:10

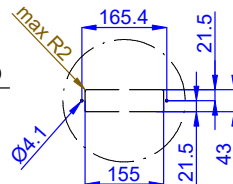

Dettaglio D
Scala 1:7

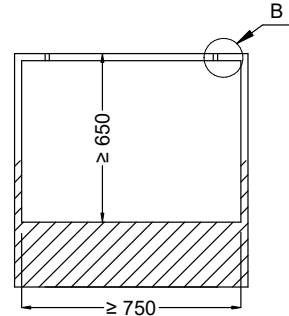

Section Cut A-A
Scala: 1:10

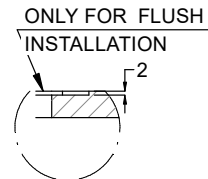

Dettaglio B
Scala 1:2

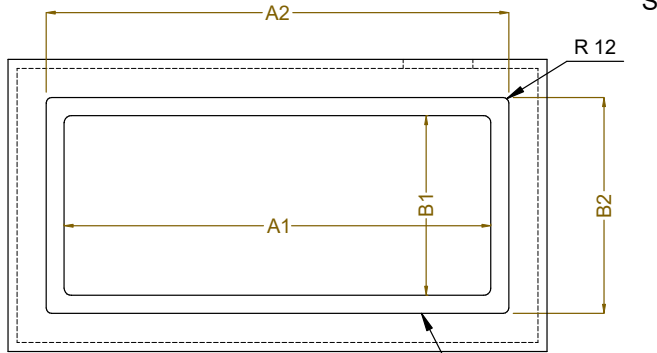

Top view
Scala: 1:10

CAPACITY	CUTOUT		LOWERING FOR FLUSH INSTALLATION		C
	A1	B1	A2	B2	
2GN	740		774		880
3GN	1070	580	1104	624	1200
4GN	1390		1424		1530

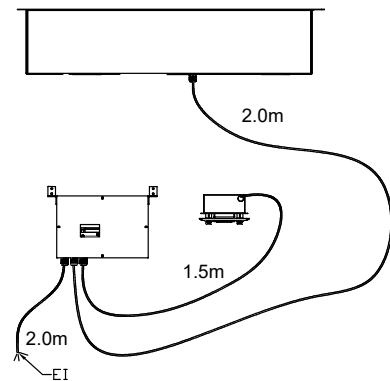
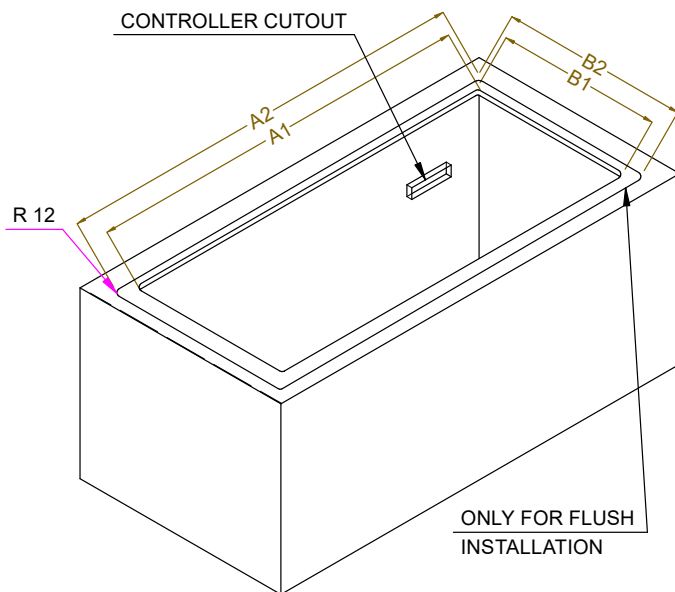

595T03400 - AIR BAIN MARIE OVERSH. ON THE FRAME