

Warewashing hygiene&clean Undercounter, atm boiler, double skin,water soft,drain p,det&rinse aid disp,DIN10512 and A0 60 compliant

ITEM # _____

MODEL # _____

NAME # _____

SIS # _____

AIA # _____



502724 (EUCA060WS)

hygiene&clean Undercounter Dishwasher with atmospheric boiler, double skin, built-in continuous water softener, drain pump, detergent and rinse aid dispensers, complies with DIN 10512 and EN 15883-1 standards reaching A0 60 disinfection level, 3 phase, 40B/H or 480D/H

Short Form Specification

Item No. _____

Unit shall be hygiene&clean undercounter type hot water rinsing dishmachine using rack dimension of 500*500mm which is designed for higher sanitation requirement. Electrical characteristics to be 400 volts three phase 50Hz operation, convertible to single phase on-site. Unit complies with DIN 10512 standard and performs at the disinfection level A0 60 according to EN 15883-1 standard. Washing performance is ensure by a powerful wash pump, large capacity wash tank, upper and lower revolving spray arms. Soft start wash pump to avoid accidental breakage of crystal wares. 90°C rinse temperature and pressure guaranteed by built in atmospheric boiler and built in rinse booster pump. Three automatic cycles fordifferent types of wares. Continuous water softener (CWS) to ensure complete and automatic regeneration of rinse water without pressure drop. Double skin insulated, counter-balance door. Double skin cabinet. Pressed wash tank with round corners. 304 AISI stainless steel construction to include door, external panels, frame, wash tank, tank filters, wash arms and rinse arms. The unit shall include drain pump, deetergent and rinse aid dispenser pumps and is equipped with electric cable.

Main Features

- Incorporated Soft Start feature to offer additional protection to more delicate items.
- Washing system endowed with rotating washing arms, high powered wash pump and large capacity boiler for professional washing.
- 4 second (variable) pause after washing and before rinsing ensures that no drops of unclean water will fall on the clean items at the end of the rinsing cycle.
- Fully automatic self-cleaning cycle avoids the risk of bacteria proliferation.
- Simple control panel with digital display allows on-site personalization of washing and rinsing cycle times and temperatures as well as precise rinse aid and detergent quantities to suit customer's needs.
- Simple service from the front.
- IPx4 water protection.
- Digital read-out keeps operator informed as to temperatures.
- State-of-the-art electronic controls with built-in programming, self-diagnostics for serviceability and automatic interior self-cleaning cycle.
- Unique temperature interlock guarantees required temperatures in both the wash and final rinse in case of emergency cold water feeding.
- Double skinned insulated wall ensures a low noise level and a reduction in heat loss from the machine.
- High efficiency air gap (class A) in water inlet circuit to avoid water being siphoned back into the network as a result of a sudden drop in main pressures.
- Low noise level.
- Slanted wash arms to avoid detergent-filled wash water dropping on clean dishes after the rinsing phase, thus guaranteeing ideal washing results.
- Solid double skinned counter-balance door with hurt-free handle fully in stainless steel.
- Built-in rinse aid and detergent dispenser with automatic initial and continuous cycle loading for perfect result while minimizing service and maintenance needs.
- An effective rinse system uses only 7,5 litres of clean hot water per basket for perfect sanitization.
- Continuous water softener (CWS) to ensure complete and automatic regeneration of rinse water without pressure drop.
- Constant temperature of 90 °C throughout the rinsing cycle regardless of the network's water pressure.
- Built-in atmospheric boiler sized to raise incoming 50 °C water to 90 °C minimum for sanitizing rinse. No external booster is required.
- Designed to efficiently disinfect items thus fulfilling hospital requirements by guaranteeing a temperature of 90 °C during 30 seconds rinsing phase.
- Front loading of regeneration salt: 2 resin containers alternate for non-stop washing.
- Three phase or single phase electrical connection, convertible on-site.

APPROVAL: _____

- Washing capacity of 12 baskets or 216 dishes per hour.

Construction

- Unit to feature smooth surfaces to facilitate cleaning.
- 304 stainless steel boiler with higher welding protection to increase resistance to corrosion.
- PVC water supply hose with metal connections resistant to high water pressure.
- Completely closed on the back by a cover plate.
- Element protection from dry fire and low water.
- Interchangeable wash/rinse arms screw out for simple clean up.
- The boiler drain facilitates the evacuation of stagnant water after long periods of inactivity to ensure a higher level of hygiene.
- Incorporated drain pump to control water level in wash tank draining.
- Large deep drawn wash tank and internal wash area with round corners and no pipes to avoid dirt built-up.
- Revolving Stainless steel wash/rinse arms above and below the basket.
- Large tank filter collects the soil to keep the wash water clean for a longer time and have better washing performance.
- Front panel, door, wash tank, tank filters, wash arms and rinse arms made in heavy duty anti-corrosive 304 AISI stainless steel.

- Basket for 5 trays 530x325 mm - red, for PNC 867006
undercounter (top level), utensil
dishwashers, hood type, rack type
- Basket for 48 small cups or 24 cups - PNC 867007
blue
- Wire basket for 12 plates up to 320 mm PNC 867014
- Cover rack for small and light items PNC 867016
(500x500 baskets)
- Basket for 16 vertical glasses (h 70 mm - PNC 867023
diam 100 mm) - blue
- Basket semi-professional PNC 867024
500x500x190mm

Sustainability



- Pre-arrangement for HACCP system implementation and Energy Management device.
- Unit to feature drain pump, rinse aid and detergent dispenser pumps.

Included Accessories

- 2 of Yellow cutlery container PNC 864242
- 1 of Basket for 12 soup bowls - green PNC 867000
- 1 of Basket for 48 small cups or 24 PNC 867007
cups - blue

Optional Accessories

- Stand for undercounter dishwasher PNC 860418
- External detergent level probe kit PNC 864004
- External rinse aid level probe kit PNC 864005
- Kit 4 castors for double skin PNC 864008
undercounter dishwashers
- Kit 4 flanged feet for undecounter PNC 864009
dishwashers
- Stainless steel inlet hose kit PNC 864016
- Kit to measure total and partial PNC 864050
water hardness
- Detergent dosing kit PNC 864218
- Yellow cutlery container PNC 864242
- Filter for total demineralization PNC 864367
- Pressure reducer for single tank PNC 864461
dishwasher
- Half size basket universal PNC 864527
- Half size basket for plates PNC 864528
- Half size basket for glasses PNC 864529
- Kit 4 plastic boxes for cutlery - PNC 865574
yellow
- Basket for 18 dinner plates - yellow PNC 867002

Front

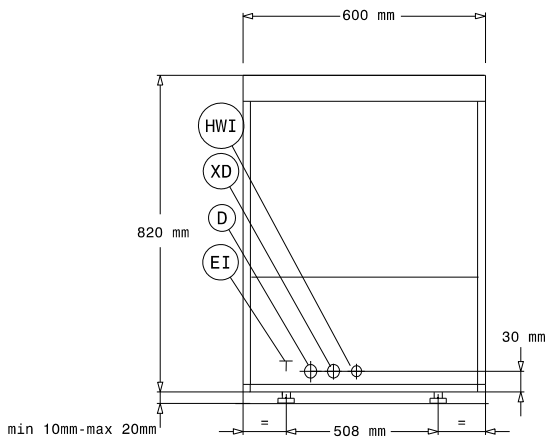

Side

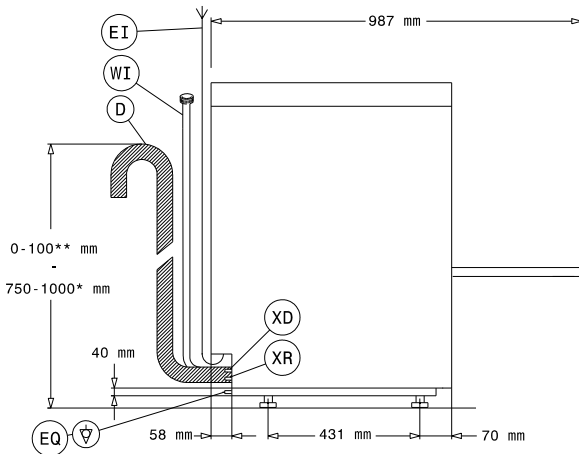

* With drain pump
 ** Without drain pump

- D = Drain
- EI = Electrical inlet (power)
- EO = Electrical Outlet
- HWI = Hot water inlet
- XD = Detergent connection
- XR = Rinse aid connection

Top

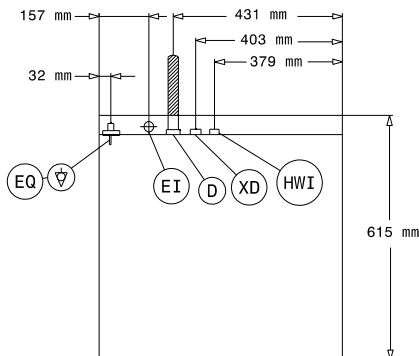

Electric

Supply voltage:	400 V/3N ph/50 Hz
Convertible to:	230V 3~; 230V 1N~
Default Installed Power:	6.85 kW
Boiler heating elements:	6 kW
Tank heating elements:	2 kW
Wash pump size:	0.736 kW

Water:

Pressure, min-max:	0.5-7 bar
Water supply temperature*:	50 °C
Drain line size:	20.5mm
Inlet Water supply pressure:	7 - 102 psi (0.5 - 7 bar)
Washing tank capacity (lt):	23
Water consumption per cycle (lt):	/ 3
Boiler Capacity (lt):	12

Key Information:

Wash temperature:	71-77°C
Cell dimensions - width:	500 mm
Cell dimensions - depth:	500 mm
Cell dimensions - height:	335 mm
Rinse temperature:	90 °C
External dimensions, Width:	600 mm
External dimensions, Depth:	615 mm
External dimensions, Height:	820 mm
Packaging size (WxDxH):	600x612x850 mm
Baskets per hour:	40
Dishes per hour:	480
Program Cycle time:	90/120/240

Sustainability

Noise level:	61 dBA
--------------	--------