

**Coffee System**  
**Mira Traditional espresso machine, 2 groups, tall cup configuration, 10.1 liter boiler**

ITEM # \_\_\_\_\_

MODEL # \_\_\_\_\_

NAME # \_\_\_\_\_

SIS # \_\_\_\_\_

AIA # \_\_\_\_\_

**602510 (MIRA2TSA)**

Traditional espresso machine, 2 groups, tall cup configuration, 10,1 liter boiler, 2 independent control boxes with 4 programmable dosing program

### Short Form Specification

Item No. \_\_\_\_\_

The MIRA line takes on the challenge of offering a dynamic outline with a sleek and streamlined design combining Stainless steel, Plexiglass and chromed components, and a full operational potential in the semi-automatic professional machine category. With this tall cup configuration, the barista can easily prepare large size drinks according to the larger cup clearance available. MIRA's technical features enable it to warrant consistently outstanding coffee quality throughout the day, while maintaining its reputation of quality and reliability that has resulting from a long-standing experience. Among its features, independent control boxes to control the volumetric commands, manual Steamglide lever to control the steam level horizontally and precisely via a ceramic cartridge, hot water dispenser with 2 programmable time-delay keys, steam dispenser with 1 programmable time-delay key

### Main Features

- Automatic cleaning cycle.
- The MIRA line offers a dynamic outline with a sleek and streamlined design combining Stainless steel, Plexiglass and chromed components.
- Its technical features enable it to warrant consistently outstanding coffee quality throughout the day, while maintaining its reputation of quality and reliability that has resulting from a long-standing experience. Among its features, independent control boxes to control the volumetric commands, manual Steamglide lever to control the steam level horizontally and precisely via a ceramic cartridge, hot water dispenser with 2 programmable time-delay keys, steam dispenser with 1 programmable time-delay key.
- 2 independent control boxes with 4 programmable dosing keys.
- The tall cup configuration allows the barista to easily prepare large size drinks according to the larger cup clearance available.
- Traditional espresso machine.
- Steamair milk auto-frother programmable outlet.
- Programmable water.

### Construction

- Stainless steel body.
- Manual Steamglide lever.
- 2 groups - 10.1 liter boiler.

### Included Accessories

- 1 of Mira filter holder for one cup PNC 871002
- 2 of Mira filter holder for two cups PNC 871003

### Optional Accessories

- Doser Coffee Grinder, flat, 65mm PNC 602543
- Doser Coffee Grinder, flat, 75mm PNC 602544
- Grind-on-demand Coffee Grinder, flat, 75mm PNC 602546
- Steam outlet with adjustable flow PNC 871000
- Hot water outlet with adjustable flow PNC 871001
- Mira filter holder for one cup PNC 871002
- Mira filter holder for two cups PNC 871003
- Mira filter holder for three cups PNC 871004
- Knock box drawer for 2-group machines PNC 871006
- Side milk refrigerator 8 liter nominal capacity for up to 4 liter milk containers PNC 871014

APPROVAL: \_\_\_\_\_

- Side milk refrigerator 8 liter nominal capacity for up to 4 liter milk containers with digital display PNC 871015
- Stainless steel 57 mm tamper PNC 871016
- Filter for one cup, 12 gr PNC 871017
- Filter for two cups, 18 gr PNC 871018
- Stainless steel knock box drawer PNC 871019
- Raised feet kit PNC 871041

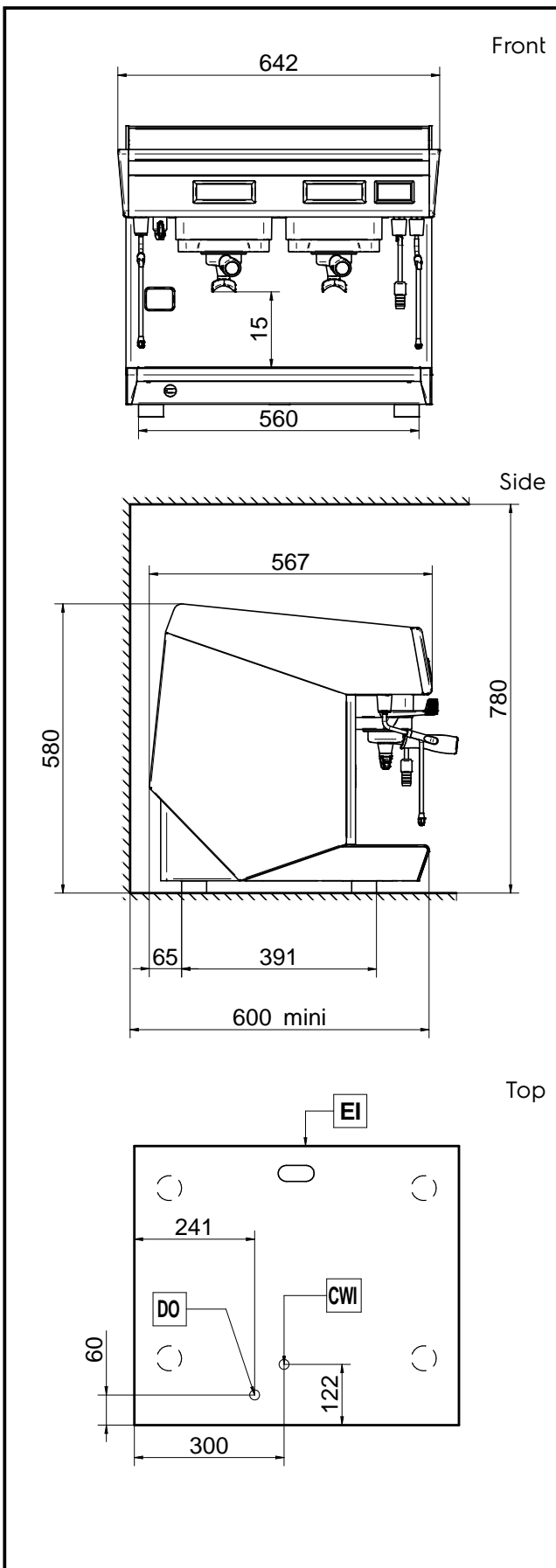

### Electric

Supply voltage:	
602510 (MIRA2TSA)	400 V/3N ph/50 Hz
Electrical power max.:	4.7 kW
Current consumption:	7 Amps
Plug type:	

### Water:

Cold water temperature (min/max):	5 / 60 °C
-----------------------------------	-----------

### Key Information:

External dimensions, Width:	642 mm
External dimensions, Depth:	570 mm
External dimensions, Height:	581 mm
Net weight:	66 kg
Shipping volume:	0.69 m <sup>3</sup>