

## Handling System for Rack Type Trays Cord Conveyor Curve 45° with Legs

ITEM # \_\_\_\_\_

MODEL # \_\_\_\_\_

NAME # \_\_\_\_\_

SIS # \_\_\_\_\_

AIA # \_\_\_\_\_



863198 (HSTCC45C)

45° curve unit with legs for  
cord conveyor for trays

### Main Features

- Range allows a large number of conveyor combinations.
- Wall mounted on request.
- Available as optional accessory a remote easy-to reach emergency-stop buttons fitted where required.
- Anti tray-jamming system.
- Other angles available on request.
- No stacking trays in curves increase the speed of the outside cord.

### Construction

- For trays up to 375x530mm.
- All surfaces smooth with polished finish.
- Constructed in AISI 304 1,5mm stainless steel.
- Stainless steel square 40x40mm tubular legs.
- 15mm reinforced polyurethane cord, for smooth and easy running.
- Free-standing construction delivered with 40x40mm legs.
- Stainless steel plain conveyor base for easy cleaning.

APPROVAL: \_\_\_\_\_



**Electrolux**  
PROFESSIONAL

## Handling System for Rack Type Trays Cord Conveyor Curve 45° with Legs

Front

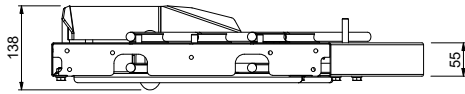

Top

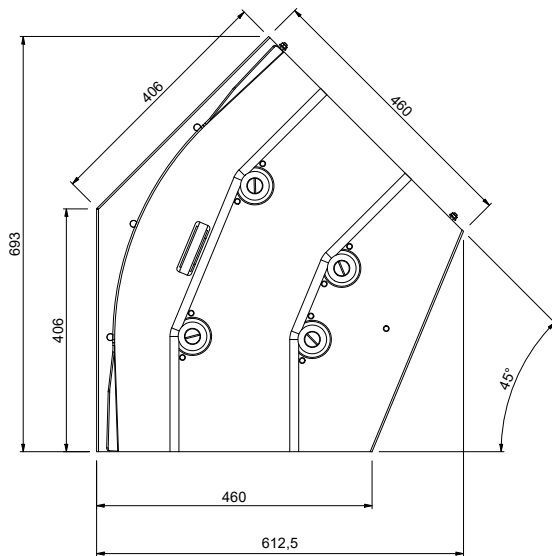

D = Drain

### Key Information:

External dimensions, Width:

863198 (HSTCC45C) 693 mm

External dimensions, Depth: 612 mm

External dimensions, Height: 138 mm

Net weight: 10 kg

Basin material: Stainless Steel AISI 304 - EN 1.4301



Handling System for Rack Type  
Trays Cord Conveyor Curve 45° with Legs

The company reserves the right to make modifications to the products  
without prior notice. All information correct at time of printing.

2026.03.09