



Electrolux
PROFESSIONAL

Handling System for Rack Type Drive Unit with Legs, Variable Speed and Cord Conveyor

ITEM # _____

MODEL # _____

NAME # _____

SIS # _____

AIA # _____



863199 (HSTCCDU5)

Drive unit with variable speed and legs for cord conveyor for trays

Main Features

- Range allows a large number of conveyor combinations.
- Hidden screws eliminate dirt traps.
- Frontal access for easy maintenance.
- Frame integrated motor for easier cleaning of floor.
- Conveyor speed controlled 4 to 15 m/min depending on capacity.
- Available as optional accessory a remote easy-to reach emergency-stop buttons fitted where required.
- Straight Drive Unit sustain up to 20 m; with each additional 90° curve the capability decreases by 4 m. For longer distances Central Units are needed.

Construction

- 304 AISI stainless steel construction throughout.
- Free-standing construction delivered with 40x40mm legs.
- Thick welded flanges for sturdy connection between the units.
- For trays up to 375x530mm.
- All surfaces smooth with polished finish.
- Stainless steel square 40x40mm tubular legs.
- Fiber glass reinforcement with 15mm polyurethane cord.
- Main electrical controls protected in a water-resistant electrical cabinet.
- Optional step by step loading for maximum accumulation of trays on the conveyor.

APPROVAL: _____



Experience the Excellence
www.electroluxprofessional.com

Front

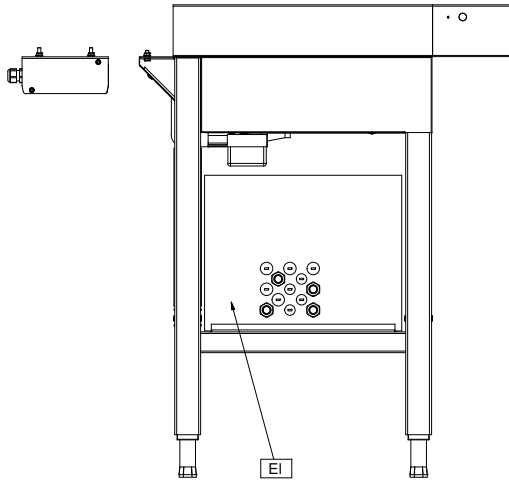

Side

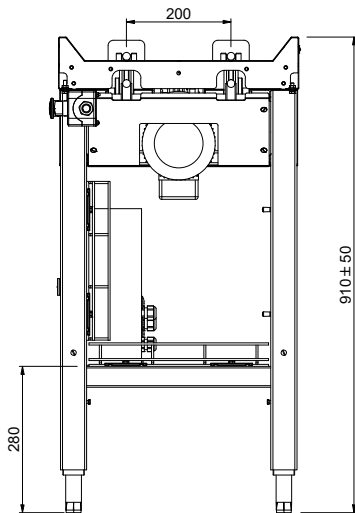

EI = Electrical inlet (power)

Top

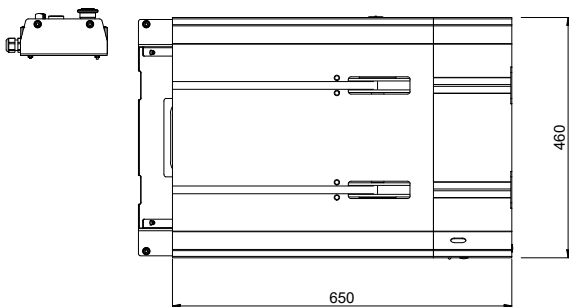
Electric

Supply voltage: 230 V/1N ph/50/60 Hz
 Electrical power, max: 0.75 kW

Key Information:

External dimensions, Width: 650 mm
 External dimensions, Depth: 460 mm
 External dimensions, Height: 910 mm
 Net weight: 35 kg
 Basin material: Stainless Steel AISI 304 - EN 1.4301
 Feeding motors number: 1
 Number of speeds: Variable
 Max. speed: 13 m/min
 Min. speed - m/min: 6 m/min