

**Warewashing
 green&clean dual rinse rack type
 dishwasher, 200racks/hour, electric,
 60Hz (Marine)**

ITEM # _____

MODEL # _____

NAME # _____

SIS # _____

AIA # _____

CC0FW1 (CC0FW1)

 Dual rinse rack type
 dishwasher, 200 racks/hour,
 CLEAR BLUE Filtering
 System, electric, touch
 screen, customized direction
 on-site, USPH compliant,
 60Hz - Marine

Short Form Specification

Item No. _____

Unit to be dual rinse rack type dishwasher. Dual rinse with built-in stabilized pressure valve ensures the right rinsing pressure for optimum hygiene results. Maximum Water Contact (MWC) wash arms are positioned along the full length of the wash tank. Included medium pre-wash zone works with cold water of maximum 40°C. Powerful wash pump and specially designed wash spray arms guarantee cleaning. Washing is done with water circulating at 55-65°C. Final rinsing is done with clean water heated up to 85°C. Dual rinse technology provides rinse water covering maximum the rinse area to ensure hygiene on washed wares. Low rinse water consumption of 0.9liters per rack at maximum speed of 200racks/hour. Three conveyor speeds are selectable by the operator with maximum capacity of 200racks/hour. Intuitive touch screen control panel provides easy communication on different levels. Large counter-balance door has heat and noise insulation with easy internal access. CLEAR BLUE filtering system removes majority of soil from the wash water to ensure clean water for long time. Built-in drain valve in the tank allows automatic dump and fill to refresh the water in the tank without interruption. Standard end of the day self cleaning cycle and sanitation cycle. Operating direction of the machine is decided by customer on-site depending on the layout flow with pre-arranged right to left from the factory.

Main Features

- IP25 protection against water jets, solid objects and small animals (larger than 6 mm).
- Built-in drain valve in the tanks allows automatic dump and fill to refresh the water in the tank without any interruption of the washing process.
- CLEAR BLUE filtering system removes soil from the wash water providing cleaner water and highly active detergent thus ensuring better washing performance and lower running costs.
- Pre-wash section uses cold water so food remains are not "baked" onto the plates in order to have better pre-wash performance.
- Intuitive touch screen control panel features user-friendly display to easily operate the machine and to monitor machine status. Three different levels of interaction are available each show relevant messages and information to the operator, the general maintenance staff and the authorized service partners.
- All internal components: wash and rinse arms, tank filters, curtains can be easily removed for cleaning.
- Unit equipped with USB port making it simple to read data such as machine identification, counters and consumption, components, devices and alarm logs. Machine parameters can be uploaded and downloaded and firmware updated.
- Large counter balanced inspection door allow unrestricted all-round access to the wash and rinse area. Door is insulated with injected foam. This adds strength as well as reduces noise and heat loss.
- Automatic drain, clean and sanitize cycles featured as standard. The internal chamber, is completely cleaned or sanitized avoiding bacteria proliferation for maximum hygiene and reducing manual work/time for operator.
- Dual rinse technology ensures maximum rinse water covering every corner of the rack inside the rinse area for perfect hygiene on washed wares.
- Three conveyor speeds can be selected through the control panel by the operator and customized on-site.
- The unit is ready to be connected with OnE Connectivity for 24/7 real time monitoring, increasing equipment uptime, maximum profit and optimizing your process.
- Maximum capacity per hour of 200 racks easy to switch to DIN 10510 compliant or other speed.
- USPH performance compliant.

Construction

- Adjustable feet for full access underneath the machine for cleaning.
- Deep drawn pressed wash tank with fully rounded corners, sloped towards the drain to prevent dirt buildup, provides fast drainage in just a few minutes. With no welding points the pressed tank offers a guaranteed water tight solution.
- Modularity design allows the machine not only be disassembled for delivery and re-assembled at customer's site, but also to be customized and upgraded on-site and over time.

APPROVAL: _____



- Dishwasher structure is held together with a solid 50 x 50 mm stainless steel frame to provide long-term sturdiness.
- All electric components are put in one IP65 central box isolated from water and steam to ensure high reliability.
- External pre-arrangement for inlet water, drain water, detergent & rinse aid connections for fast and easy installation on both sides of the unit.
- All main components made in heavy duty anti-corrosive 304 type stainless steel: external front, side panels and internal chambers, wash and rinse arms, doors and rack transportation system.
- The unit is designed for marine application as components is easily accessible from front for service and maintenance without removing the machine.
- Kit electronic connection for motorized table and remote pre wash module for Dual Rinse Rack Type Dishwasher PNC 865508
- Pipe extension kit for additional 22 " pre-wash module on Dual Rinse Rack Type Dishwasher with ESD PNC 865509
- Kit ESD for Dual Rinse Rack Type Dishwasher (Marine) PNC 865510
- Set of 6 baskets: 2 for trays, 2 for plates, 1 for cutlery and 1 for cups PNC 867050
- Set of 9 baskets: 2 for trays, 3 for plates, 2 for cutlery and 2 for cups PNC 867051

Sustainability



- Auto-start/stop equipped in different zones ensures that the zone runs only when a rack is passing through it. This reduces water, energy, chemical consumption and noise.
- All chambers without internal pipes and therefore no hidden dirt traps.
- Built-in stabilized pressure valve ensures constant pressure throughout the rinsing cycle regardless of inlet water pressure.
- Self-draining vertical wash pumps provide maximum hygiene.
- Automatic back-up mode is activated when a failure occurs. Guided troubleshooting for fast fixes including 150 precises notifications and 23 easy-to-follow processes.
- Dual rinse with stabilized pressure valve guarantees rinse water consumption of 0.9 liters/ rack regardless of inlet water pressure to ensure low energy, water, detergent and rinse aid consumption.

Optional Accessories

- Medium pre-wash zone for green&clean Dual Rinse Rack Type Dishwasher, 60Hz - Marine PNC 535131
- Medium hot air blower zone without door for Dual Rinse Rack Type dishwasher, 60Hz - Marine PNC 535138
- Large drying zone with door for green&clean Dual Rinse Rack Type Dishwasher, 60Hz - Marine PNC 535139
- Corner drying zone for green&clean Dual Rinse Rack Type Dishwasher, 60Hz - Marine PNC 535140
- Emergency stop kit for Rack Type Dishwasher (not for Basic handling system) PNC 865162
- End limit switch for short roller conveyor PNC 865218
- End limit switch for long roller conveyor (kit with two short rollers and end switch) PNC 865256
- Kit to convert pre-wash module to wash module PNC 865281
- Kit water meter PNC 865286
- Splash hood kit for single and dual rinse Rack Type Dishwasher, 200 mm PNC 865498
- Silicon curtains for single and dual rinse Rack Type dishwasher PNC 865503
- Kit electronic board for Dual Rinse Rack Type Dishwasher PNC 865506
- Kit delime & door cleaning for dual for Rinse Rack Rack Type Dishwasher PNC 865507



Components

- 1 of **535127** (EDRI50EC6M) Dual rinse rack type dishwasher, 150 racks/hour, CLEAR BLUE Filtering System, electric, touch screen, customized direction on-site, USPH compliant, 60Hz - Marine
 - **Shipping weight:** 260 kg
 - **Shipping height:** 1951 mm
 - **Shipping width:** 1006 mm
 - **Shipping depth:** 1255 mm
 - **Shipping volume:** 2.46 m³
 - **Current consumption:** 0 Amps
- 1 of **535131** (NMPWDRE6M) Medium pre-wash zone for green&clean Dual Rinse Rack Type Dishwasher, 60Hz - Marine
 - **Shipping weight:** 122 kg
 - **Shipping height:** 2030 mm
 - **Shipping width:** 910 mm
 - **Shipping depth:** 700 mm
 - **Shipping volume:** 1.29 m³
 - **Current consumption:** 0 Amps
- 1 of **865506** (KITEBDR) Kit electronic board for Dual Rinse Rack Type Dishwasher
 - **Shipping weight:** 0.65 kg
 - **Shipping height:** 110 mm
 - **Shipping width:** 290 mm
 - **Shipping depth:** 190 mm
 - **Shipping volume:** 0.01 m³
 - **Current consumption:** 0 Amps

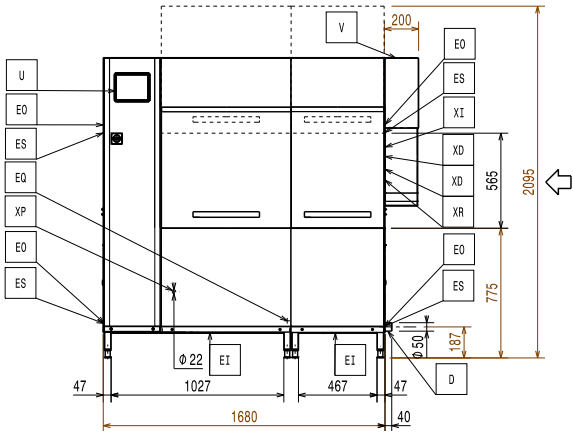
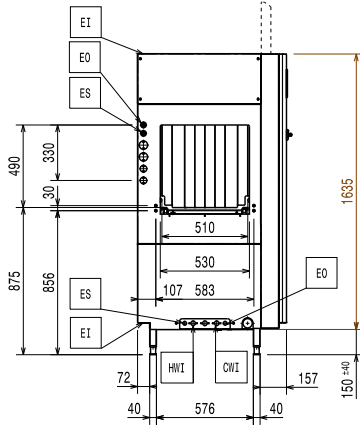
Front

Side

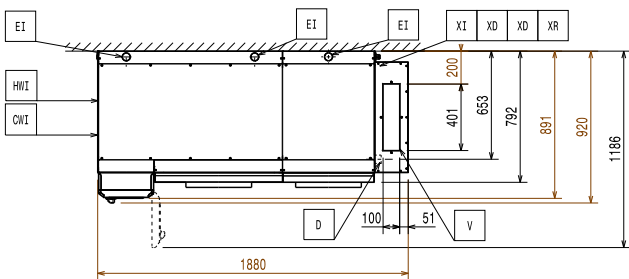
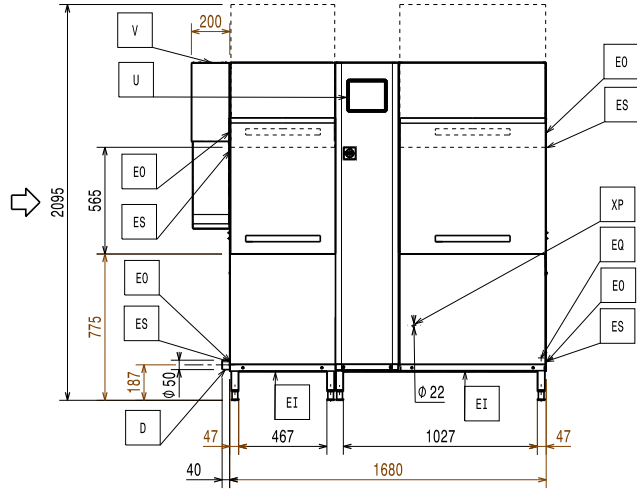
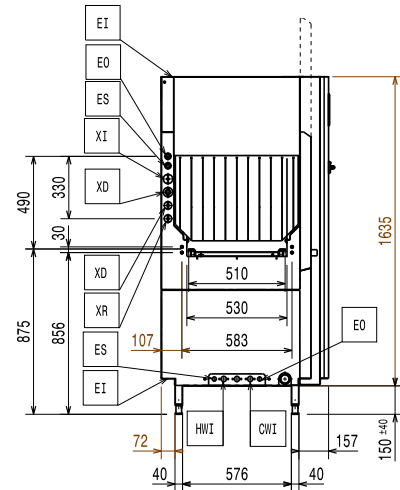
- CWI = Cold Water Inlet
- D = Drain
- EI = Electrical inlet (power)
- EO = Electrical Outlet
- EQ = Equipotential screw
- ES = Electrical signal IN/OUT
- U = USB port

Top

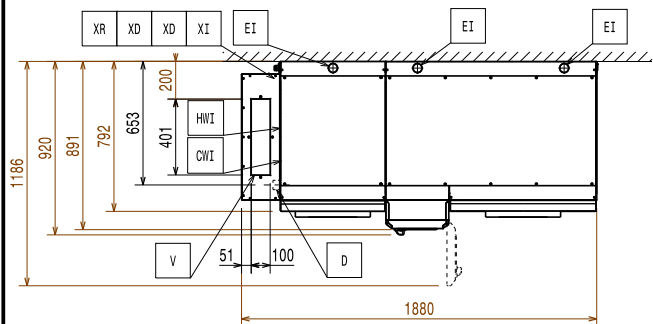
Front

Side

- CWI = Cold Water Inlet
- D = Drain
- EI = Electrical inlet (power)
- EO = Electrical Outlet
- EQ = Equipotential screw
- ES = Electrical signal IN/OUT
- U = USB port

Top

Electric

When the machine is run at DIN 10510 compliant speed. Pre-wash tank heating element are activated only during sanitation cycle.

Supply voltage:	440 V/3 ph/60 Hz
Pre-wash tank heating elements:	7 kW
Default Installed Power:	42.3 kW
Boiler heating elements:	20 kW
Pre-wash pump size:	0.37 kW
Electrical power, min:	22.3 kW
Wash pump size:	1.2 kW
Wash tank heating elements:	20 kW

Water:

Inlet cold water line size:	G 3/4"
Inlet water supply temperature, pre-wash:	10-30°C
When below 7°F/4°dH special detergent and rinse aid are needed.	
Peak rate of drain flow:	2.5 l/s
Pre-wash tank size:	35 l
Wash tank size:	70 l
Inlet hot water line size:	
Drain line size:	50mm
Inlet water supply pressure:	1.5-6 bar
Inlet water supply temperature (wash and rinse):	50 - 65°C
Inlet water supply hardness:	5-8 °fH / 2.8-4.5°dH
Rinse water consumption:	180 l/h

Key Information:

For transportation purpose only, the depth can be reduced to either 895mm by removing the main switch button or 797mm by removing the control box and the door handle.

Reference norm used to measure the noise:
 IEC60335-2-58 annex AA.

Table to table distance:	1680 mm
Height with door open:	2095 mm
Charging hole size (width):	530 mm
Rinse temperature:	86 °C
Productivity per hour (max. speed):	200 racks/3600dishes
Productivity per hour (medium speed):	148 racks/2664 dishes
External dimensions, Width:	1880 mm
External dimensions, Depth:	925 mm
External dimensions, Height:	1785 mm
Productivity per hour (DIN compliant speed):	95 racks/1710 dishes
Charging hole size (height):	490 mm
Wash Temperature:	71 - 76 °C
Pre-wash temperature:	10-40°C

Air Emission:

Air temperature:	
CC0FW1 (CC0FW1)	27 °C
Air humidity (entrance, exit):	
CC0FW1 (CC0FW1)	100 / 100 % r.h.

Sensible heat:	3400 W
Air flow (entrance, exit):	86 / 145 m³/h

The data is measured at exhaust points at 25°C and 60% r.h. ambient conditions, 18°C inlet water temperature and refer only to the machine.

This model requires a ventilation hood. Please refer to the attached "Recommended Exhaust Hood Design".

Sustainability

Noise level:	<62 dBA
Rinse water consumption at max speed:	0.9 l/rack



Electrolux
PROFESSIONAL

Warewashing
green&clean dual rinse rack type dishwasher,
200racks/hour, electric, 60Hz (Marine)

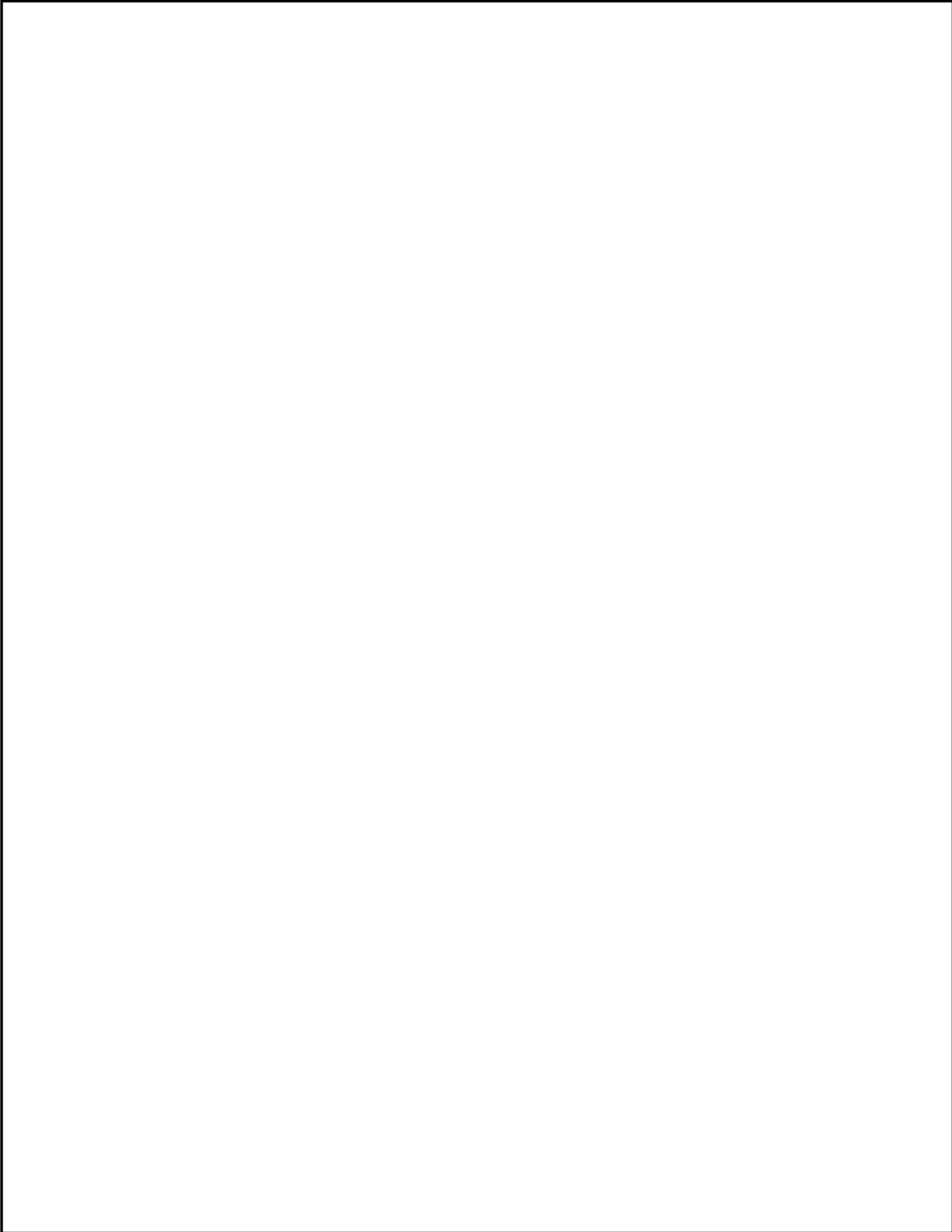

Warewashing
green&clean dual rinse rack type dishwasher, 200racks/hour, electric,
60Hz (Marine)
The company reserves the right to make modifications to the products
without prior notice. All information correct at time of printing.

2026.06.08