

**Warewashing  
 green&clean dual rinse rack type  
 dishwasher with Steam abatement, 200r/  
 h, electric, 60Hz (Marine)**

ITEM # \_\_\_\_\_

MODEL # \_\_\_\_\_

NAME # \_\_\_\_\_

SIS # \_\_\_\_\_

AIA # \_\_\_\_\_

**CC0FW2 (CC0FW2)**

 Dual rinse rack type  
 dishwasher, 200 racks/hour,  
 Energy Saving Device,  
 CLEAR BLUE Filtering  
 System, electric, touch  
 screen, customized direction  
 on-site, USPH compliant,  
 60Hz - Marine

### Short Form Specification

**Item No.** \_\_\_\_\_

Unit to be dual rinse rack type dishwasher. Operating direction right to left or left to right. Featured built-in Steam abatement working with chilled water to absorb the hot steam generated inside the machine. Dual rinse with built-in stabilized pressure valve ensures the right rinsing pressure for optimum hygiene results. Maximum Water Contact (MWC) wash arms are positioned along the full length of the wash tank. Included medium pre-wash zone works with cold water of maximum 40°C. Powerful wash pump and specially designed wash spray arms guarantee cleaning. Washing is done with water circulating at 55-65°C. Final rinsing is done with clean water heated up to 85°C. Dual rinse technology provides rinse water covering maximum the rinse area to ensure hygiene on washed wares. Low rinse water consumption of 0.9liters per rack at maximum speed of 200racks/hour. Three conveyor speeds are selectable by the operator with maximum capacity of 200racks/hour. Intuitive touch screen control panel provides easy communication on different levels. Large counter-balance door has heat and noise insulation with easy internal access. CLEAR BLUE filtering system removes majority of soil from the wash water to ensure clean water for long time. Built-in drain valve in the tank allows automatic dump and fill to refresh the water in the tank without interruption. Standard end of the day self cleaning cycle and sanitation cycle. Operating direction of the machine is decided by customer on-site depending on the layout flow with pre-arranged right to left from the factory.

### Main Features

- IP25 protection against water jets, solid objects and small animals (larger than 6 mm).
- Intuitive touch screen control panel features user-friendly display to easily operate the machine and to monitor machine status. Three different levels of interaction are available each show relevant messages and information to the operator, the general maintenance staff and the authorized service partners.
- All internal components: wash and rinse arms, tank filters, curtains can be easily removed for cleaning.
- Unit equipped with USB port making it simple to read data such as machine identification, counters and consumption, components, devices and alarm logs. Machine parameters can be uploaded and downloaded and firmware updated.
- Built-in drain valve in the tanks allows automatic dump and fill to refresh the water in the tank without any interruption of the washing process.
- CLEAR BLUE filtering system removes soil from the wash water providing cleaner water and highly active detergent thus ensuring better washing performance and lower running costs.
- Pre-wash section uses cold water so food remains are not "baked" onto the plates in order to have better pre-wash performance.
- Large counter balanced inspection door allow unrestricted all-round access to the wash and rinse area. Door is insulated with injected foam. This adds strength as well as reduces noise and heat loss.
- Automatic drain, clean and sanitize cycles featured as standard. The internal chamber, is completely cleaned or sanitized avoiding bacteria proliferation for maximum hygiene and reducing manual work/time for operator.
- Dual rinse technology ensures maximum rinse water covering every corner of the rack inside the rinse area for perfect hygiene on washed wares.
- Three conveyor speeds can be selected through the control panel by the operator and customized on-site.
- The unit is ready to be connected with OnE Connectivity for 24/7 real time monitoring, increasing equipment uptime, maximum profit and optimizing your process.
- Maximum capacity per hour of 200 racks easy to switch to DIN 10510 compliant or other speed.
- Built-in Steam Abatement using chilled water to absorb the hot steam generated by the machine thus releasing dry and fresh air to the dishwashing area.

### Construction

- Dishwasher structure is held together with a solid 50 x 50 mm stainless steel frame to provide long-term sturdiness.
- All electric components are put in one IP65 central box isolated from water and steam to ensure high reliability.
- External pre-arrangement for inlet water, drain water, detergent & rinse aid connections for fast

**APPROVAL:** \_\_\_\_\_



and easy installation on both sides of the unit.

- All main components made in heavy duty anti-corrosive 304 type stainless steel: external front, side panels and internal chambers, wash and rinse arms, doors and rack transportation system.
- Modularity design allows the machine not only be disassembled for delivery and re-assembled at customer's site, but also to be customized and upgraded on-site and over time.
- Deep drawn pressed wash tank with fully rounded corners, sloped towards the drain to prevent dirt buildup, provides fast drainage in just a few minutes. With no welding points the pressed tank offers a guaranteed water tight solution.
- The unit is designed for marine application as components is easily accessible from front for service and maintenance without removing the machine.
- Adjustable feet for full access underneath the machine for cleaning.

### Sustainability



- Auto-start/stop equipped in different zones ensures that the zone runs only when a rack is passing through it. This reduces water, energy, chemical consumption and noise.
- All chambers without internal pipes and therefore no hidden dirt traps.
- Built-in stabilized pressure valve ensures constant pressure throughout the rinsing cycle regardless of inlet water pressure.
- Self-draining vertical wash pumps provide maximum hygiene.
- Automatic back-up mode is activated when a failure occurs. Guided troubleshooting for fast fixes including 150 precises notifications and 23 easy-to-follow processes.
- Dual rinse with stabilized pressure valve guarantees rinse water consumption of 0.9 liters/ rack regardless of inlet water pressure to ensure low energy, water, detergent and rinse aid consumption.

### Optional Accessories

- |  |            |                          |
|--|------------|--------------------------|
| • Medium hot air blower zone without door for Dual Rinse Rack Type dishwasher, 60Hz - Marine                   | PNC 535138 | <input type="checkbox"/> |
| • Large drying zone with door for green&clean Dual Rinse Rack Type Dishwasher, 60Hz - Marine                   | PNC 535139 | <input type="checkbox"/> |
| • Corner drying zone for green&clean Dual Rinse Rack Type Dishwasher, 60Hz - Marine                            | PNC 535140 | <input type="checkbox"/> |
| • Emergency stop kit for Rack Type Dishwasher (not for Basic handling system)                                  | PNC 865162 | <input type="checkbox"/> |
| • End limit switch for short roller conveyor   | PNC 865218 | <input type="checkbox"/> |
| • End limit switch for long roller conveyor (kit with two short rollers and end switch)                        | PNC 865256 | <input type="checkbox"/> |
| • Kit water meter  | PNC 865286 | <input type="checkbox"/> |
| • Silicon curtains for single and dual rinse Rack Type dishwasher  | PNC 865503 | <input type="checkbox"/> |
| • Kit delime & door cleaning for dual for Rinse Rack Rack Type Dishwasher                                      | PNC 865507 | <input type="checkbox"/> |
| • Kit electronic connection for motorized table and remote pre wash module for Dual Rinse Rack Type Dishwasher | PNC 865508 | <input type="checkbox"/> |
| • Set of 6 baskets: 2 for trays, 2 for plates, 1 for cutlery and 1 for cups                                    | PNC 867050 | <input type="checkbox"/> |
| • Set of 9 baskets: 2 for trays, 3 for plates, 2 for cutlery and 2 for cups                                    | PNC 867051 | <input type="checkbox"/> |

## Components

- 1 of **535127** (EDRI50EC6M) Dual rinse rack type dishwasher, 150 racks/hour, CLEAR BLUE Filtering System, electric, touch screen, customized direction on-site, USPH compliant, 60Hz - Marine
  - **Shipping weight:** 260 kg
  - **Shipping height:** 1951 mm
  - **Shipping width:** 1006 mm
  - **Shipping depth:** 1255 mm
  - **Shipping volume:** 2.46 m<sup>3</sup>
  - **Current consumption:** 0 Amps
- 1 of **535131** (NMPWDRE6M) Medium pre-wash zone for green&clean Dual Rinse Rack Type Dishwasher, 60Hz - Marine
  - **Shipping weight:** 122 kg
  - **Shipping height:** 2030 mm
  - **Shipping width:** 910 mm
  - **Shipping depth:** 700 mm
  - **Shipping volume:** 1.29 m<sup>3</sup>
  - **Current consumption:** 0 Amps
- 1 of **865506** (KITEBDR) Kit electronic board for Dual Rinse Rack Type Dishwasher
  - **Shipping weight:** 0.65 kg
  - **Shipping height:** 110 mm
  - **Shipping width:** 290 mm
  - **Shipping depth:** 190 mm
  - **Shipping volume:** 0.01 m<sup>3</sup>
  - **Current consumption:** 0 Amps
- 1 of **865510** (KITESDDRM) Kit ESD for Dual Rinse Rack Type Dishwasher (Marine)
  - **Shipping weight:** ISO 9001 kg
  - **Shipping height:** 490 mm
  - **Shipping width:** 740 mm
  - **Shipping depth:** 930 mm
  - **Shipping volume:** 0.34 m<sup>3</sup>
  - **Current consumption:** 0 Amps
- 1 of **865509** (KITEPESDDR22) Pipe extension kit for additional 22" pre-wash module on Dual Rinse Rack Type Dishwasher with ESD
  - **Shipping weight:** 3.9 kg
  - **Shipping height:** 290 mm
  - **Shipping width:** 380 mm
  - **Shipping depth:** 780 mm
  - **Shipping volume:** 0.09 m<sup>3</sup>
  - **Current consumption:** 0 Amps
- 1 of **865498** (KITSHSRE) Splash hood kit for single and dual rinse Rack Type Dishwasher, 200 mm
  - **Shipping weight:** 13 kg
  - **Shipping height:** 480 mm
  - **Shipping width:** 380 mm
  - **Shipping depth:** 780 mm
  - **Shipping volume:** 0.14 m<sup>3</sup>
  - **Current consumption:** 0 Amps

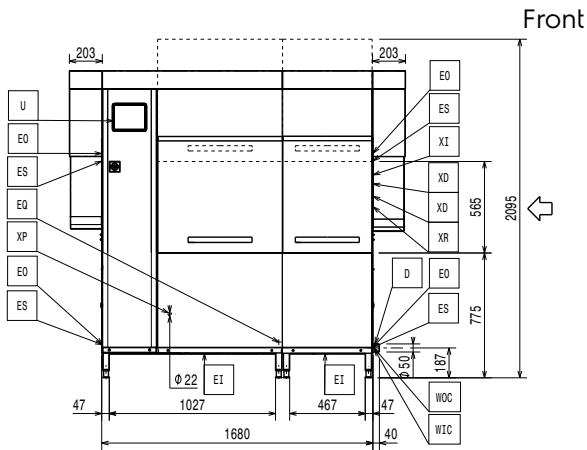

Side

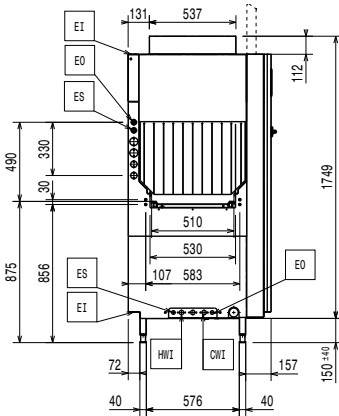

- CWI = Cold Water Inlet
- D = Drain
- EI = Electrical inlet (power)
- EO = Electrical Outlet
- EQ = Equipotential screw
- ES = Electrical signal IN/OUT
- HWI = Hot water inlet
- U = USB port
- WI = Water inlet

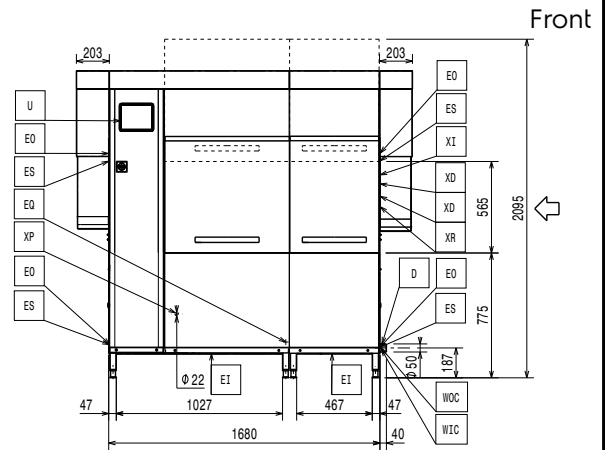
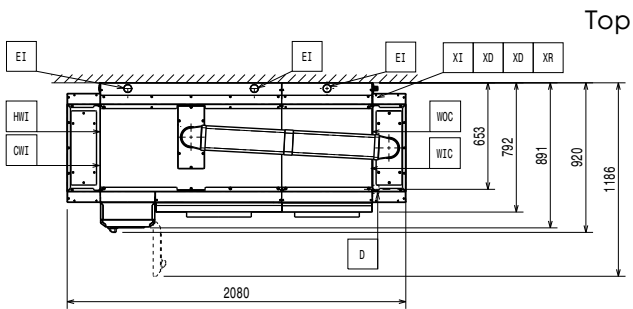

Side

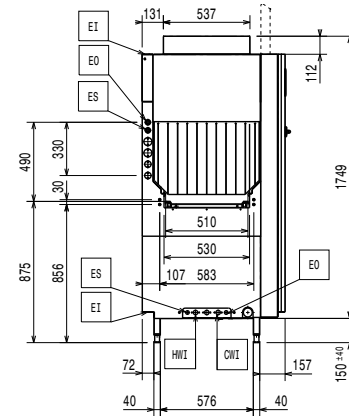

- CWI = Cold Water Inlet
- D = Drain
- EI = Electrical inlet (power)
- EO = Electrical Outlet
- EQ = Equipotential screw
- ES = Electrical signal IN/OUT
- HWI = Hot water inlet
- U = USB port
- WI = Water inlet

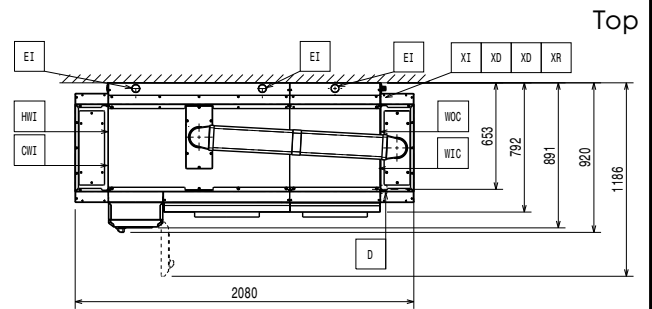

**Electric**

When the machine is run at DIN 10510 compliant speed.  
 Pre-wash tank heating element are activated only during sanitation cycle.

<b>Supply voltage:</b>	440 V/3 ph/60 Hz
<b>Pre-wash tank heating elements:</b>	7 kW
<b>Default Installed Power:</b>	42.5 kW
<b>Boiler heating elements:</b>	20 kW
<b>Pre-wash pump size:</b>	0.37 kW
<b>Electrical power, min:</b>	22.5 kW
<b>Wash pump size:</b>	1.2 kW
<b>Wash tank heating elements:</b>	20 kW

**Water:**

<b>Inlet cold water line size:</b>	G 3/4"
<b>Inlet Water Supply temperature (pre-wash):</b>	10 - 30°C
When below 7°FH/4°dH special detergent and rinse aid are needed.	
<b>Peak rate of drain flow:</b>	2.5 l/s
<b>Pre-wash tank size:</b>	35 l
<b>Wash tank size:</b>	70 l
<b>Inlet hot water line size:</b>	G 3/4"
<b>Drain line size:</b>	50mm
<b>Inlet water supply pressure:</b>	1.5-6 bar
<b>Inlet water supply temperature (wash and rinse):</b>	50 - 65°C
<b>Inlet water supply temperature (Steam abatement):</b>	5 - 10 °C
<b>Inlet water supply hardness:</b>	5-8 °fH / 2.8-4.5°dH

**Key Information:**

For transportation purpose only, the depth can be reduced to either 895mm by removing the main switch button or 797mm by removing the control box and the door handle.

Reference norm used to measure the noise: IEC60335-2-58 annex AA.

<b>Table to table distance</b>	1680 mm
<b>Height with door open:</b>	2095 mm
<b>Charging hole size (width):</b>	530 mm
<b>Rinse temperature:</b>	86 °C
<b>Productivity per hour (max. speed):</b>	200 racks/3600dishes
<b>Productivity per hour (medium speed):</b>	148 racks/2664 dishes
<b>External dimensions, Width:</b>	2080 mm
<b>External dimensions, Depth:</b>	925 mm
<b>External dimensions, Height:</b>	1908 mm
<b>Productivity per hour (DIN compliant speed):</b>	95 racks/1710 dishes
<b>Charging hole size (height):</b>	490 mm
<b>Wash Temperature:</b>	71 - 76 °C
<b>Pre-wash temperature:</b>	10-40°C

**Air Emission:**

<b>Air temperature:</b>	
CC0FW2 (CC0FW2)	25.5 °C
<b>Air humidity (entrance, exit):</b>	
CC0FW2 (CC0FW2)	100 / 0 % r.h.
<b>Latent heat:</b>	4100 W
<b>Sensible heat:</b>	2600 W
<b>Air flow (entrance, exit):</b>	565 / 0 m <sup>3</sup> /h

The data is measured at exhaust points at 25°C and 60% r.h. ambient conditions, 18°C inlet water temperature and refer only to the machine.

This model requires a ventilation hood. Please refer to the attached "Recommended Exhaust Hood Design".

<b>Noise level:</b>	<62 dBA
<b>Rinse water consumption at max speed:</b>	0.9 l/rack



**Electrolux**  
PROFESSIONAL

Warewashing  
green&clean dual rinse rack type dishwasher  
with Steam abatement, 200r/h, electric, 60Hz  
(Marine)

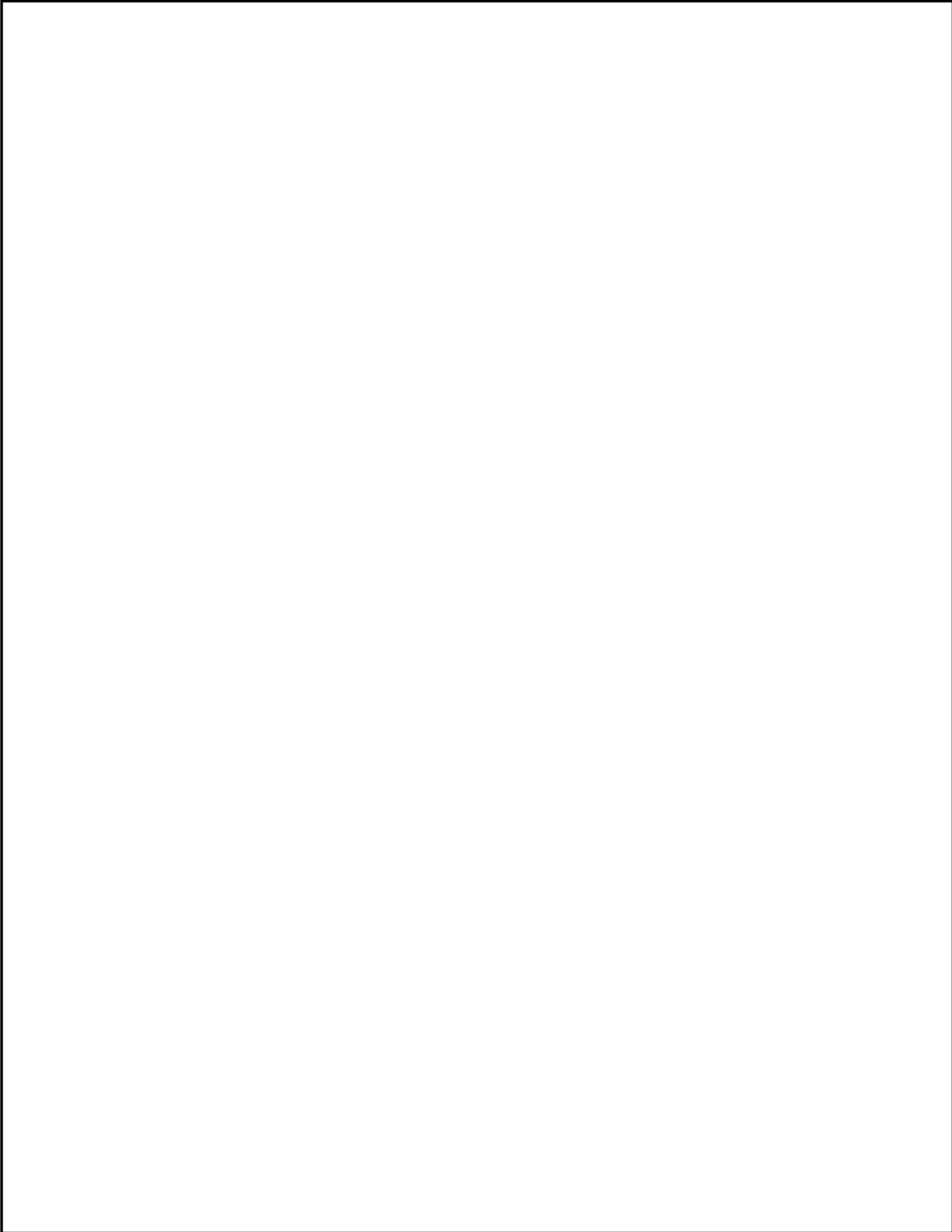

Warewashing  
green&clean dual rinse rack type dishwasher with Steam abatement,  
200r/h, electric, 60Hz (Marine)  
The company reserves the right to make modifications to the products  
without prior notice. All information correct at time of printing.

2026.06.08