

**Modular Cooking Range Line
 thermaline 85 - Full Surface Induction
 Top on Electric Oven with Left Tap, 1
 Side, Backsplash**

ITEM # _____

MODEL # _____

NAME # _____

SIS # _____

AIA # _____



588663 (MBJHGBK8AO) Full Surface Induction Top on electric static Oven, with left-side water mixing tap, one-side operated with backsplash

Short Form Specification

Item No. _____

Unit constructed according to DIN 18860_2 with 20 mm drop nose top and 70 mm recessed plinth. Internal frame for heavy duty sturdiness in stainless steel. 2 mm top in 1.4301 (AISI 304). Flat surface construction, easily cleanable. THERMODUL connection system enables seamless worktop when units are connected and avoids soil penetrating. Large multi-coil glass ceramic surface without any "dead" spots allows for quick and easy cleaning. Features 9 power levels with fast deployment to full heating power and very low heat dissipation to kitchen. Overheat protection switches off the supply in case of overheating. Metal knobs with embedded hygienic silicon "soft" grip enable easier handling and cleaning. Electric static oven chamber with 40 mm thick oven door and ribbed enamelled steel base plate. Oven chamber with 2 levels of runners for 2/1 GN shelves to enable simultaneous and faster cooking. Heavy duty thermostat with temperature range up to 300°C, electronic sensor for precise temperature control and manual humidity control in the cooking chamber. Upper heating element can also be used for grilling, with or without ventilating mode.
 IPX5 water resistant certification.
 Configuration: Freestanding, one side operated with backsplash and left tap.

Main Features

- Almost the entire surface of the ceramic plate can be used without "dead" spots.
- Fast deployment with full heating power immediately.
- Low heat dissipation to the kitchen.
- Overheat protection: the temperature sensor switches off the supply in case of overheating.
- Pans can easily be moved from one area to another without lifting.
- The large surface multi-coil induction top offers a substantial increase in pan and pot capacity thanks to the seamless transition between individual heating zones, ideal for à la carte operation.
- The smooth glass-ceramic surface can be quickly and easily cleaned, thus providing maximum hygiene.
- All major components may be easily accessed from the front.
- THERMODUL connection system creates a seamless work top when units are connected to each other thus avoiding soil penetrating vital components and facilitating the removal of units in case of replacement or service.
- Metal knobs with embedded hygienic "soft-touch" grip for easier handling and cleaning. The special design of the controls prevents infiltration of liquids or soil into vital components.
- 9 power levels.
- Handles are ergonomically designed with silicon "soft" grip for easy handling and cleaning.
- Oven chamber to have 2 levels of runners to accommodate 2/1 GN trays and ribbed enamelled steel base plate.
- Heavy duty thermostat with temperature range up to 300°C.
- The upper heating element of the oven can also be used for grilling.
- Manual control of humidity in cooking chamber.
- Electronic sensor for precise temperature control.

Construction

- Control light for each zone.
- 2 mm top in 1.4301 (AISI 304).
- Unit constructed according to DIN 18860_2 with 20 mm drop nose top and 70 mm recessed plinth.
- Flat surface construction with minimal hidden areas to easily clean all surfaces
- IPX5 water resistance certification.

APPROVAL: _____

- Internal frame for heavy duty sturdiness in stainless steel.

Sustainability



- This model is compliant with Swiss Energy Efficiency Ordinance (730.02).

Included Accessories

- 1 of Grid, chromium plated, for ovens 2/1 GN PNC 910652

Optional Accessories

- Scraper for cook tops PNC 910601
- Baking sheet 2/1 GN for ovens PNC 910651
- Fire clay plate 2/1 GN for ovens PNC 910656
- Connecting rail kit for appliances with backsplash, 850mm PNC 912498
- Stainless steel front kicking strip, 1200mm width PNC 912638
- Stainless steel side kicking strip left and right, wall mounted, 850mm width PNC 912659
- Stainless steel side kicking strip left and right, back-to-back, 1700mm width PNC 912662
- Stainless steel plinth, against wall, 1200mm width PNC 912886
- Stainless steel side panel, 850x700mm, right side, against wall PNC 913003
- Stainless steel side panel, 850x700mm, left side, against wall PNC 913004
- Back panel, 1200x700mm, for units with backsplash PNC 913017
- Endrail kit, flush-fitting, with backsplash, left PNC 913115
- Endrail kit, flush-fitting, with backsplash, right PNC 913116
- Endrail kit (12.5mm) for thermaline 85 units with backsplash, left PNC 913206
- Endrail kit (12.5mm) for thermaline 85 units with backsplash, right PNC 913207
- Insert profile, d=850mm PNC 913231
- Side reinforced panel only in combination with side shelf, for against the wall installations, right PNC 913261
- Side reinforced panel only in combination with side shelf, for against the wall installations, left PNC 913262
- Filter W=1200mm PNC 913667
- Stainless steel dividing panel, 850x700mm, (it should only be used between Electrolux Professional thermaline Modular 85 and thermaline C85) PNC 913670
- Stainless steel side panel, 850x700mm, flush-fitting (it should only be used against the wall, against a niche and in between Electrolux Professional thermaline and ProThermetic appliances and external appliances - provided that these have at least the same dimensions) PNC 913686

Front

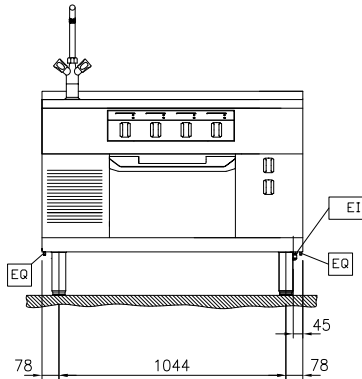

Side

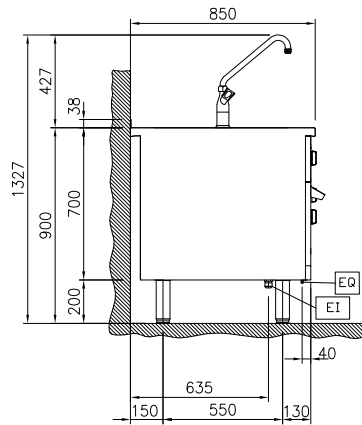

CWI1 = Cold Water inlet 1 (cleaning)
 EI = Electrical inlet (power)
 EQ = Equipotential screw
 HWI = Hot water inlet

Top

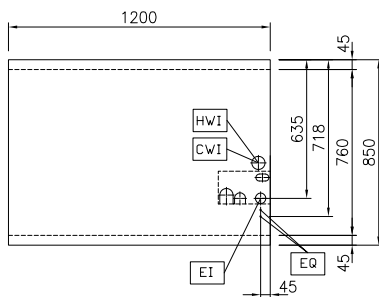
Electric

Supply voltage: 400 V/3N ph/50/60 Hz
 Total Watts: 33 kW

Key Information:

Oven working Temperature: 60 °C MIN; 300 °C MAX
 Oven Cavity Dimensions (width): 575 mm
 Oven Cavity Dimensions (height): 300 mm
 Oven Cavity Dimensions (depth): 700 mm
 External dimensions, Width: 1200 mm
 External dimensions, Depth: 850 mm
 External dimensions, Height: 700 mm
 Net weight: 216 kg

Configuration: On Oven, One-Side Operated
 Front Plates Power: 7 - 7 kW
 Back Plates Power: 7 - 7 kW
 Front Plates dimensions: 420x370 420x370
 Oven GN: GN 2/1
 Back Plates dimensions: 420x370 420x370

Sustainability

Current consumption: 51.2 Amps