

## Refrigeration Equipment 3-Door Mega Top Prep 70 " Long 30-1/6 Pan

ITEM # \_\_\_\_\_

MODEL # \_\_\_\_\_

NAME # \_\_\_\_\_

SIS # \_\_\_\_\_

AIA # \_\_\_\_\_



738262 (KCHMT70.30)

3-Door Mega Top Prep 70  
" Long 30-1/6 Pan

### Short Form Specification

**Item No.** \_\_\_\_\_

3-door mega top refrigerated preparation table. Exterior back panel and exterior bottom panel in galvanized steel, exterior side and top panel in 430 stainless steel; interior back, top and interior bottom panels in 304 stainless steel, worktop in 304 stainless steel. Built-in refrigeration unit and an insulated lid to maintain food freshness. Fin & Tube Condenser improves performance in high-temperature environments. Automatic Defrost Cooling System to provide worry-free performances. Full-depth cutting board of 71x9x0.5 in.. Control panel, Vinyl-Coated Steel adjustable shelves, removable door gaskets and self-closing doors with 90-degree stay-open feature. Temperature range: +33/+41°F.

R290 gas in the refrigeration circuit.

ETL Safety and Sanitation certifications.

3/5 Years warranty.

### Main Features

- Removable gasket for easy cleaning operations.
- Fin & Tube Condenser improves performance in high temperature environments.
- Automatic Defrost Cooling System provides worry-free performance.
- Electronic Temperature Control, quick and simple to set, with control display for easy monitoring.
- Full Depth cutting board.
- External temperature display.
- Cabinet completely insulated with high density polyurethane for low environmental impact.
- Heavy duty Vinyl coated steel shelves.

### Construction

- Self-closing door with 90-degree stay-open feature.
- Heavy duty casters.
- Insulated lid maintains food freshness.
- Holds 30 1/6 pans.
- Pre-wired heavy duty power cord.
- Heavy duty door hinges.
- Magnetic gasket removable without tools for easy cleaning.

### Sustainability

- CFC and HCFC free, highly ecological refrigerant type: R290 (ecological gas in foam: cyclopentane). Hydrocarbon refrigerant gas R290 for the lowest environmental impact (GWP=3), to reduce green house and ozone depletion effects.
- High efficiency components to minimize the energy consumption still guaranteeing the highest performances.
- Hydrocarbon refrigerant gas R290 for the lowest environmental impact (GWP=3) - CFC and HCFC free.

### Optional Accessories

- Drawer Kit for 48" Mega Top, Salad PNC 880616   
Top, Undercounter and L/R section  
of 70" Salad & Mega Top and 72"  
Undercounter
- Drawer Kit for Center Section of 70 PNC 880699   
" Salad, Mega Top Prep Table & 72"  
Undercounter

APPROVAL: \_\_\_\_\_

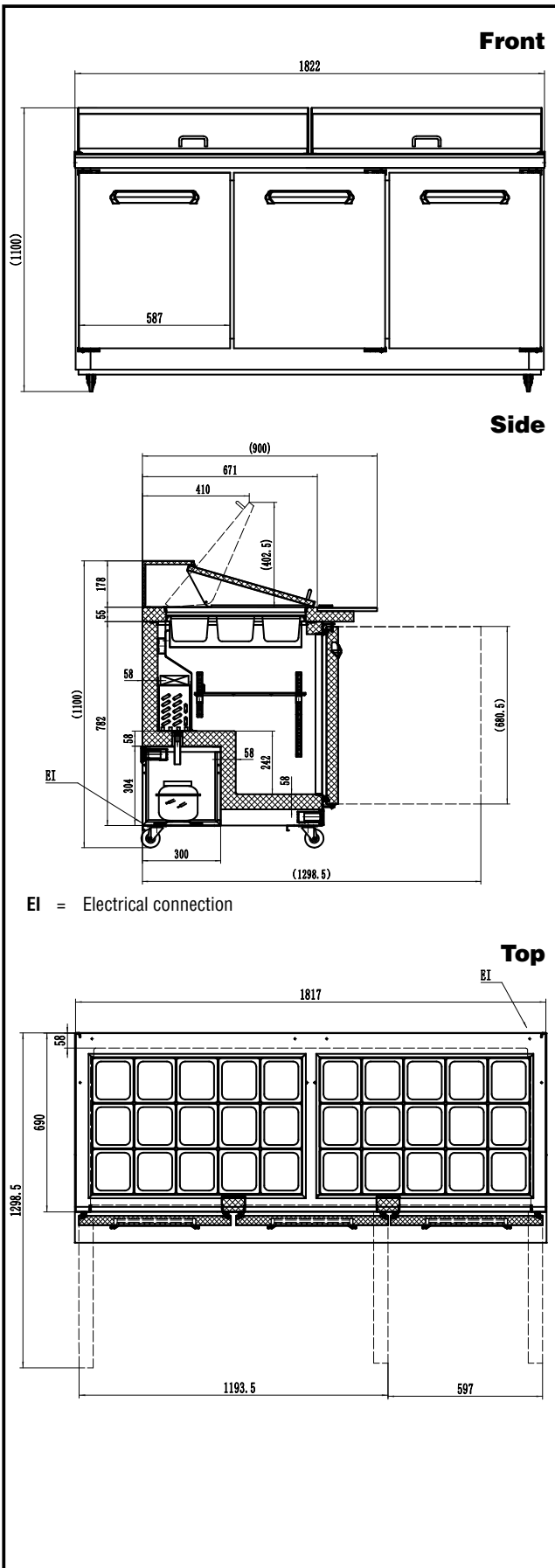

EI = Electrical connection

### Electric

Supply voltage:	738262 (KCHMT70.30)	115 V/1 ph/60 Hz
Electrical power, max:		0.72 kW
Plug type:		USA NEMA 5-15P

### Capacity:

Gross capacity:	18 cu.feet
-----------------	------------

### Key Information:

Door hinges:	1 Left+2 Right
External dimensions, Width:	71 3/4" (1822 mm)
External dimensions, Depth:	35 7/16" (900 mm)
External dimensions, Height:	43 5/16" (1100 mm)
Number and type of doors:	3 Full
Internal Dimensions (depth):	23 13/16" / (605 mm)
Internal Dimensions (height):	23 1/2" / (597 mm)
Internal Dimensions (width):	66 7/16" / (1687 mm)
Shipping height:	47 1/4" (1200 mm)
Shipping weight:	448 lbs (203 kg)
Shipping volume:	71.8 ft <sup>3</sup> (2.03 m <sup>3</sup> )
Number and type of grids (included):	3 - Vinyl-Coated Steel
Type of external material:	Stainless Steel
Type of internal material:	Polystyrene
Warranty:	3 / 5 years
Approvals	ETL C&US;ETL SANITATION

### Refrigeration Data

Compressor power:	1/3 hp
Operating temperature min.:	32 °F
Operating temperature max.:	41 °F
Condenser type:	Fin & tube
Defrost type:	Auto Defrost

### Sustainability

Current consumption:	4.3 Amps
Refrigerant type:	R290
GWP Index:	3
Refrigerant weight:	95 g



Refrigeration Equipment  
3-Door Mega Top Prep 70" Long 30-1/6 Pan

The company reserves the right to make modifications to the products without prior notice. All information correct at time of printing.