



COMMERCIAL

# Refrigeration Equipment Slide Top Bottle Cooler 37 " Long

ITEM # \_\_\_\_\_

MODEL # \_\_\_\_\_

NAME # \_\_\_\_\_

SIS # \_\_\_\_\_

AIA # \_\_\_\_\_

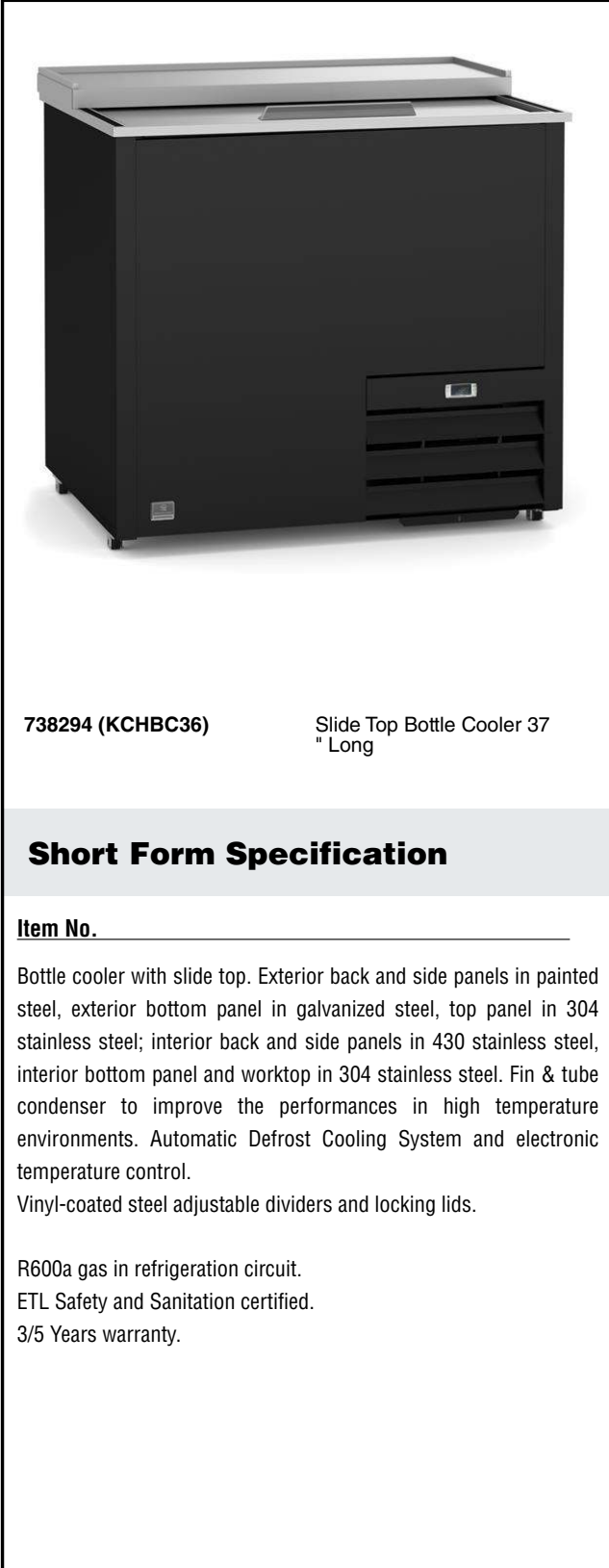

738294 (KCHBC36)

Slide Top Bottle Cooler 37  
" Long

## Short Form Specification

Item No. \_\_\_\_\_

Bottle cooler with slide top. Exterior back and side panels in painted steel, exterior bottom panel in galvanized steel, top panel in 304 stainless steel; interior back and side panels in 430 stainless steel, interior bottom panel and worktop in 304 stainless steel. Fin & tube condenser to improve the performances in high temperature environments. Automatic Defrost Cooling System and electronic temperature control.

Vinyl-coated steel adjustable dividers and locking lids.

R600a gas in refrigeration circuit.

ETL Safety and Sanitation certified.

3/5 Years warranty.

## Main Features

- Fin & Tube Condenser improves performance in high temperature environments.
- Automatic Defrost Cooling System provides worry-free performance.
- Vinyl-Coated Steel adjustable dividers to customize bottle storage effortlessly.
- Locking doors.
- External temperature display.
- Cabinet completely insulated with high density polyurethane for low environmental impact.
- Locking lids.

## Construction

- Pre-wired heavy duty power cord.
- Electronic control to select temperatures.

## Sustainability

- High efficiency components to minimize the energy consumption still guaranteeing the highest performances.
- CFC and HCFC free (ecological refrigerant type: R600a).

APPROVAL: \_\_\_\_\_

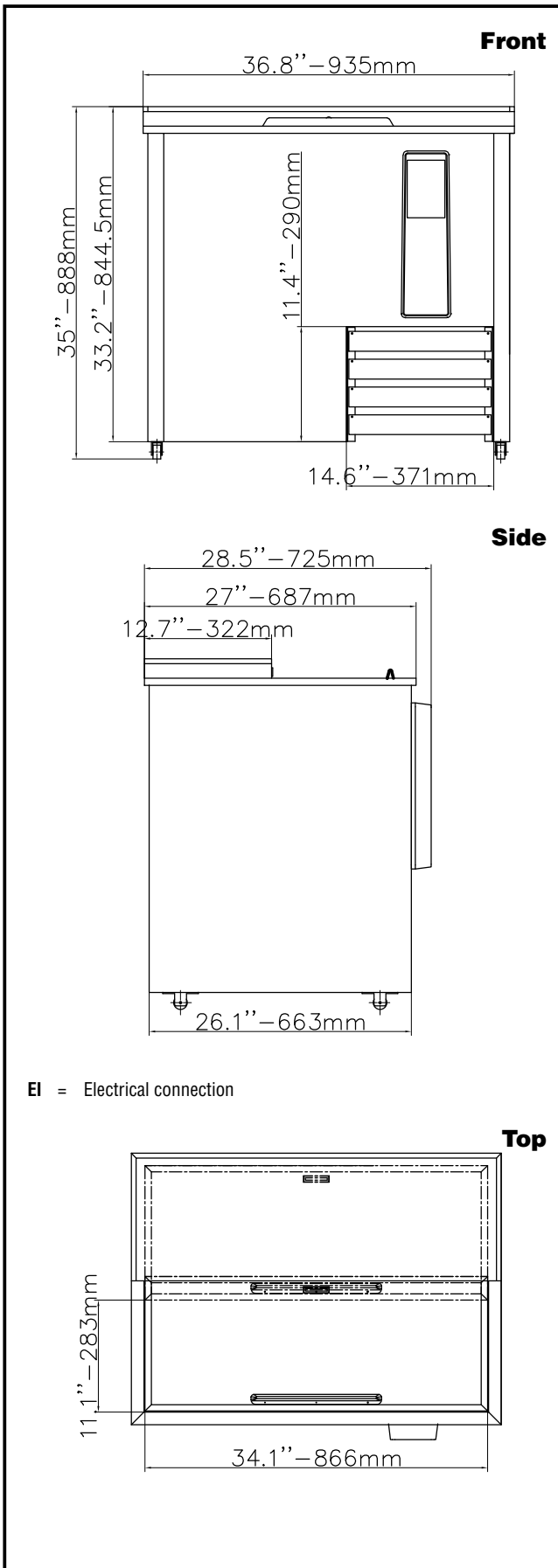

EI = Electrical connection

## Electric

Supply voltage:	115 V/1 ph/60 Hz
738294 (KCHBC36)	
Electrical power, max:	0.2 kW
Plug type:	USA NEMA 5-15P

## Capacity:

Gross capacity:	12.3 cu.feet
-----------------	--------------

## Key Information:

External dimensions, Width:	36 13/16" (935 mm)
External dimensions, Depth:	28 9/16" (725 mm)
External dimensions, Height:	34 15/16" (888 mm)
Internal Dimensions (depth):	26 1/16"
Internal Dimensions (height):	22 15/16"
Internal Dimensions (width):	60 3/8"
Shipping height:	39 3/4" (1010 mm)
Shipping weight:	187 lbs (85 kg)
Shipping volume:	25.6 ft <sup>3</sup> (0.72 m <sup>3</sup> )
Type of external material:	Black Prepainted Steel
Type of internal material:	Stainless Steel
Warranty:	3 / 5 years

## Refrigeration Data

Compressor Horsepower:	1/6
Refrigerant type:	R600a
Operating temperature min.:	ISO 9001 °F
Operating temperature max.:	41 °F
Condenser type:	Fin & tube

## Sustainability

Current consumption:	1.5 Amps
Refrigerant weight:	100 g