



COMMERCIAL

# Refrigeration Equipment 2-Door 2-Tower Draft Box 49 " Long

ITEM # \_\_\_\_\_

MODEL # \_\_\_\_\_

NAME # \_\_\_\_\_

SIS # \_\_\_\_\_

AIA # \_\_\_\_\_



738297 (KCHBBD2D2T)

2-Door 2-Tower Draft Box 49  
" Long

## Short Form Specification

Item No. \_\_\_\_\_

Beer dispenser with 2 doors and 2 columns. Exterior back and bottom panel in galvanized steel, top panel in 304 stainless steel and exterior panel in painted steel; interior back and side panels in 430 stainless steel, interior bottom panel and worktop in 304 stainless steel. Fin & tube condenser to improve the performances in high temperature environments. Automatic Defrost Cooling System and temperature control.

Vinyl heavy duty adjustable, easy to handle and clean shelves.

R290 gas in refrigeration circuit.

ETL Safety and Sanitation certified.

3/5 Years warranty.

## Main Features

- External digital temperature display.
- Fin & Tube Condenser improves performance in high temperature environments.
- Automatic Defrost Cooling System provides worry-free performance.
- Locking doors.
- External temperature display.
- Cabinet completely insulated with high density polyurethane for low environmental impact.

## Construction

- Self-closing door with 90-degree stay-open feature.
- Lockable door.
- Pre-wired heavy duty power cord.
- Heavy duty door hinges.
- Magnetic gasket removable without tools for easy cleaning.
- Heavy duty casters.

## Sustainability

- CFC and HCFC free, highly ecological refrigerant type: R290 (ecological gas in foam: cyclopentane). Hydrocarbon refrigerant gas R290 for the lowest environmental impact (GWP=3), to reduce green house and ozone depletion effects.
- High efficiency components to minimize the energy consumption still guaranteeing the highest performances.
- Hydrocarbon refrigerant gas R290 for the lowest environmental impact (GWP=3) - CFC and HCFC free.

APPROVAL: \_\_\_\_\_

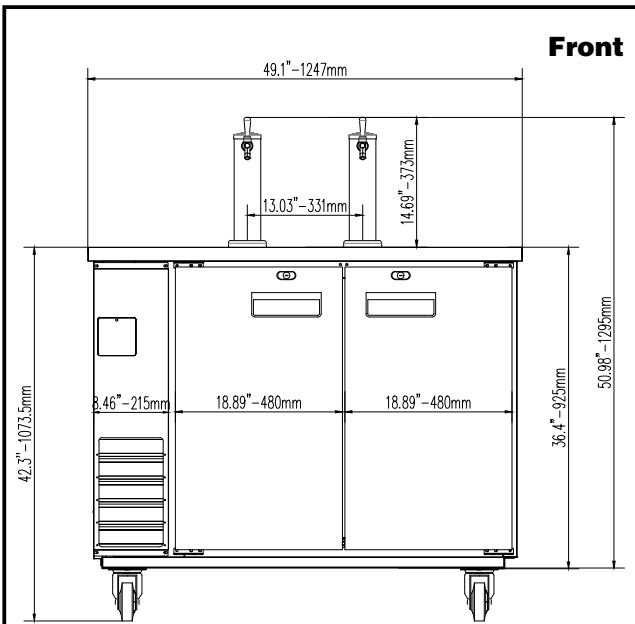

**Front**

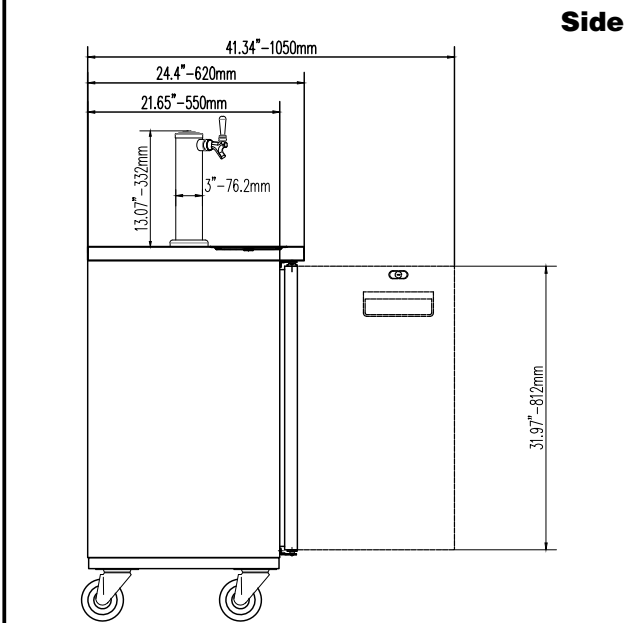

**Side**

EI = Electrical connection

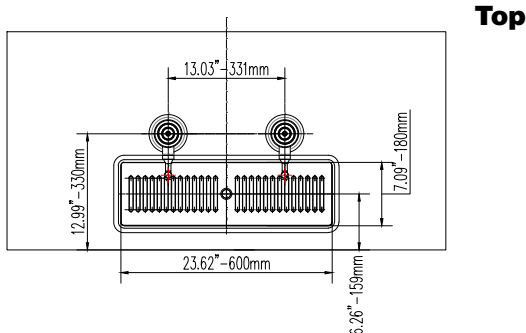

**Top**

## Electric

Supply voltage:	738297 (KCHBBD2D2T)	115 V/1 ph/60 Hz
Electrical power, max:		0.3 kW
Plug type:		USA NEMA 5-15P

## Capacity:

Gross capacity:	12.9 cu.feet
-----------------	--------------

## Key Information:

Door hinges:	
External dimensions, Width:	49 1/16" (1247 mm)
External dimensions, Depth:	24 7/16" (620 mm)
External dimensions, Height:	56 15/16" (1446.5 mm)
Number and type of doors:	2 Full
Internal Dimensions (depth):	20 1/16"
Internal Dimensions (height):	29 3/8"
Internal Dimensions (width):	39 3/16"
Shipping height:	58 11/16" (1490 mm)
Shipping weight:	265 lbs (120 kg)
Shipping volume:	56.92 ft <sup>3</sup> (1.61 m <sup>3</sup> )
Number and type of grids (included):	4 - Vinyl-Coated Steel
Type of external material:	Black Prepainted Steel
Type of internal material:	Stainless Steel
Warranty:	3 / 5 years

## Refrigeration Data

Compressor Horsepower:	1/5
Operating temperature min.:	35.6 °F
Operating temperature max.:	42.8 °F
Condenser type:	Fin & tube

## Sustainability

Current consumption:	3 Amps
Refrigerant type:	R290
Refrigerant weight:	110 g