



COMMERCIAL

# Refrigeration Equipment 2-Door Work Top Freezer 48 " Long

ITEM # \_\_\_\_\_

MODEL # \_\_\_\_\_

NAME # \_\_\_\_\_

SIS # \_\_\_\_\_

AIA # \_\_\_\_\_



738304 (KCHUCWT48F)

2-Door Work Top Freezer 48  
" Long

## Short Form Specification

Item No. \_\_\_\_\_

2-door freezer counter top with exterior back panel in aluminium, exterior bottom panel in galvanized steel, exterior side and top panel in 430 stainless steel; interior back, top and bottom panels in 304 stainless steel.

Fin & tube condenser to improve the performances in high temperature environments. Automatic Defrost Cooling System and temperature control. Vinyl heavy duty adjustable, easy to handle and clean shelves. External temperature display.

R290 gas in refrigeration circuit.

ETL Safety and Sanitation certified.

3/5 Years warranty.

## Main Features

- External temperature display.
- Removable gasket for easy cleaning operations.
- Fin & Tube Condenser improves performance in high temperature environments.
- Automatic Defrost Cooling System provides worry-free performance.
- Electronic Temperature Control, quick and simple to set, with control display for easy monitoring.
- Heavy duty Vinyl coated steel shelves.
- Cabinet completely insulated with high density polyurethane for low environmental impact.

## Construction

- Self-closing door with 90-degree stay-open feature.
- Heavy duty casters.
- Pre-wired heavy duty power cord.
- Heavy duty door hinges.
- Magnetic gasket removable without tools for easy cleaning.

## Sustainability

- CFC and HCFC free, highly ecological refrigerant type: R290 (ecological gas in foam: cyclopentane). Hydrocarbon refrigerant gas R290 for the lowest environmental impact (GWP=3), to reduce green house and ozone depletion effects.
- High efficiency components to minimize the energy consumption still guaranteeing the highest performances.
- Hydrocarbon refrigerant gas R290 for the lowest environmental impact (GWP=3) - CFC and HCFC free.

## Optional Accessories

- shelf for 48" and 72" (left/right) mega top, salad and undercounter PNC 880597
- shelf clips PNC 880611

APPROVAL: \_\_\_\_\_

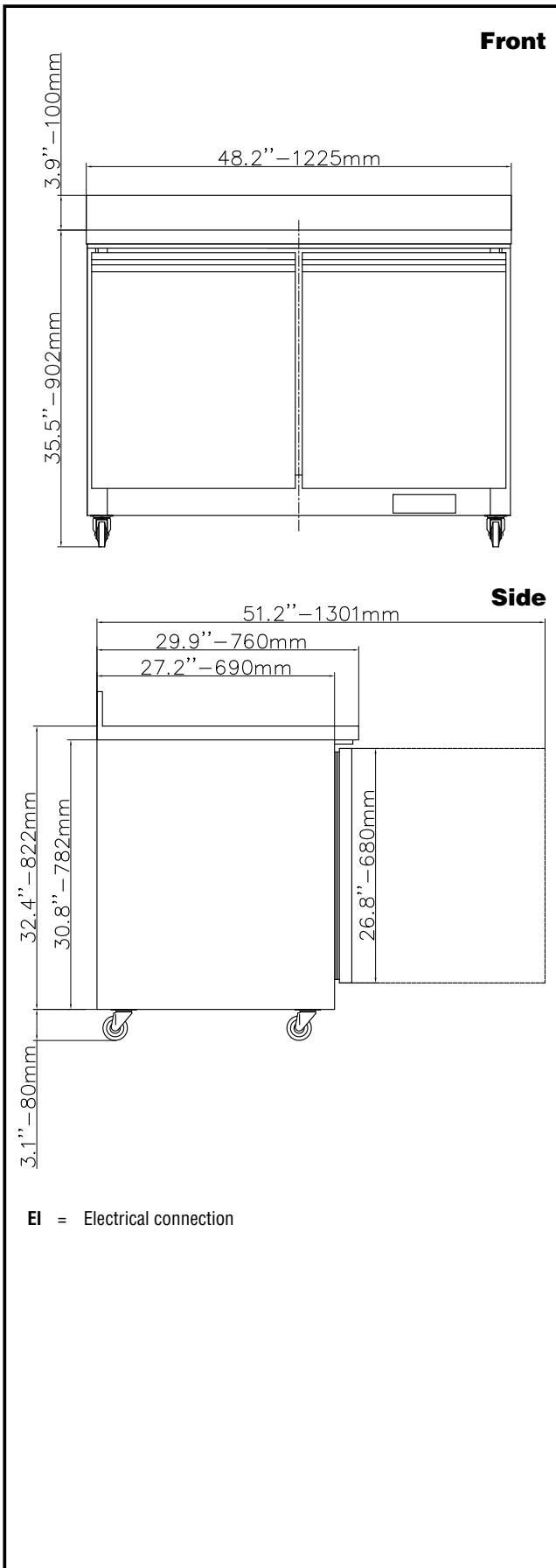

## Electric

Supply voltage:	738304 (KCHUCWT48F)	115 V/1 ph/60 Hz
Electrical power, max:		0.4 kW
Plug type:		USA NEMA 5-15P

## Key Information:

Door hinges:	1 Left+1 Right
Capacity:	15.459 cu.ft.
External dimensions, Width:	48 1/4" (1225 mm)
External dimensions, Depth:	29 15/16" (760 mm)
External dimensions, Height:	39 7/16" (1002 mm)
Number and type of doors:	2 Full
Internal Dimensions (depth):	22 13/16"
Internal Dimensions (height):	23 1/2"
Internal Dimensions (width):	42 1/2"
Shipping height:	42 1/8" (1070 mm)
Shipping weight:	276 lbs (125 kg)
Shipping volume:	38.24 ft <sup>3</sup> (1.08 m <sup>3</sup> )
Number and type of grids (included):	2 - Vinyl-Coated Steel
Type of external material:	Stainless Steel
Type of internal material:	304 AISI
Warranty:	3 / 5 years

## Refrigeration Data

Compressor Horsepower:	1/5
Operating temperature min.:	-9.4 °F
Operating temperature max.:	8.6 °F
Condenser type:	Fin & tube
Defrost type:	Auto Defrost

## Sustainability

Current consumption:	4 Amps
Refrigerant type:	R290
Refrigerant weight:	100 g