

Rapido Blast Chiller-Freezer 6GN1/1 30/30 kg for tower installation

ITEM # _____

MODEL # _____

NAME # _____

SIS # _____

AIA # _____



110545 (ZBFA61WE)

Rapido blast chiller freezer
30/30kg, 6 GN 1/1 or
600x400mm (12 levels pitch
30mm) for Tower execution
with touch screen control

Short Form Specification

Item No.

- Blast chiller freezer with high resolution full touch screen interface, multilanguage
- For 6 GN 1/1 or 600x400 mm trays. Up to 9 ice cream basins of 5 kg (165x360x125h mm)
- Load capacity: chilling 30 kg; freezing 30 kg
- AirFlow air distribution system to achieve maximum performance with 7 fan speed levels
- Chilling/Freezing modes: Automatic (10 food families with 100+ different pre-installed variants); Programs (a maximum 1000 programs can be stored and organized in 16 different categories); Manual (soft chilling, hard chilling, freezing, holding, turbo cooling and lite hot cycles); Special Cycles (Cruise chilling, proving, retarded proving, fast thawing, Sushi&Sashimi, Sous-Vide chilling, ice-cream, yogurt and chocolate)
- Special functions: MultiTimer chilling/freezing, Make-it-Mine to customize interface, Match connection to Magistar Combi Ovens, SoloMio to customize homepage, agenda Calendar
- Remaining time estimation for probe-driven cycles based on artificial intelligence techniques (ARTE 2.0)
- Automatic and manual defrosting and drying
- USB port to download HACCP data, programs and settings. Connectivity ready
- 3-point multi sensor core temperature probe
- Stainless steel construction throughout
- Internal rounded corners
- Built-in refrigeration unit
- R452a refrigerant gas
- Performance guaranteed at ambient temperatures of +43°C (Climatic class 5)
- Suitable for tower configuration

Main Features

- Blast Chilling cycle: 30 kg from +90°C up to + 3°C in less than 90 minutes.
- Chilling cycle (+10°C to -41°C) with automatic preset cycles: - Soft chilling (air temperature 0°C), ideal for delicate food and small portions. - Hard chilling (air temperature -20°C), ideal for solid food and whole pieces.
- X-Freeze cycle (+10°C to -41°C): ideal for blast freezing all kinds of food (raw, half or fully cooked).
- Lite-Hot cycle (+40°C to -18°C): ideal for soft heating preparations.
- Turbo cooling: chiller works continuously at the desired temperature; ideal for continuous production.
- Automatic mode including 10 food families (meat, poultry, fish, sauces and soup, vegetables, pasta/rice, bread, savory and sweet bakery, dessert, beverage fast cooling) with 100+ different pre-installed variants. Through Automatic Sensing Phase the blast chiller optimizes the chilling process according to size, quantity and type of food loaded to achieve the selected result. Real time overview of the chilling parameters. Possibility to personalize and save up to 70 variants per family.
- Programs mode: a maximum of 1000 programs can be stored in the blast chiller's memory, to recreate the exact same high standard at any time. The programs can be grouped in 16 different categories to better organize the menu. 16-step chilling programs also available.
- MultiTimer function to manage up to 20 different chilling cycles at the same time, improving flexibility and ensuring excellent results. Can be saved up to 200 MultiTimer programs.
- Fan with 7 speed levels. Fan stops in less than 5 seconds when door is opened.
- 3-point multi sensor core temperature probe for high precision and food safety.
- 6-point multi sensor core temperature probe for maximum precision and food safety (optional accessory).
- Remaining time estimation for probe-driven cycles based on artificial intelligence techniques (ARTE 2.0 Patented US7971450B2 and related family) for an easier planning of the activities.
- Customizable pre-cooling and pre-heating functions.
- Automatic and manual defrosting and drying.
- Multi-purpose internal structure is suitable for 6 grids GN 1/1 (12 positions available with 30 mm pitch) 6 grids or trays 600 x 400 mm (12 positions available with 30 mm pitch) or 9 ice-cream basins of 5 kg each (h 125 x 165 x 360 mm).
- Suitable for tower installation including stacking kit.
- Performance guaranteed at ambient temperatures of +43°C (Climatic class 5).
- Special Cycles: - Cruise Cycle (Patented EP1716769B1 and related family) automatically sets the parameters for the quickest and best chilling (it works with probe) - Proving - Retarded Proving - Fast Thawing - Sushi&Sashimi (anisakis-free food) - Chill Sous-vide - Ice Cream - Yogurt - Chocolate
- AirFlow air distribution system to achieve maximum

APPROVAL:

performance in chilling/heating evenness and temperature control thanks to a special design of the chamber combined with high precision variable speed fan.

- [NOT TRANSLATED]

Construction

- Built-in refrigeration unit.
- Environmentally friendly: R452a as refrigerant gas.
- Solenoid valve to automatically manage the gas pressure in the thermodynamic circuit.
- Main components in 304 AISI stainless steel.
- Evaporator with antirust protection.
- Motors and fan waterproof protected IP54.
- Seamless hygienic internal chamber with all rounded corners for easy cleaning.
- Removable magnetic gasket door with hygienic design.
- Ventilator swinging hinged panel for access to the evaporator for cleaning.
- Door stopper to keep the door open in order to avoid the formation of bad smells.
- Automatic heated door frame.
- No water connections required. Waste water can be plumbed into drain, but can also be collected in an optional waste container.

User Interface & Data Management

- High resolution full touch screen interface (translated in more than 30 languages) - color-blind friendly panel.
- Pictures upload for full customization of cycles.
- Make-it-mine feature to allow full personalization or locking of the user interface.
- USB port to download HACCP data, share chilling programs and configurations.
- Connectivity ready for real time access to connected appliances from remote and HACCP monitoring (requires optional accessory).
- Trainings and guidances supporting materials easily accessible by scanning QR-Code with any mobile device.
- Automatic consumption visualization at the end of the cycle.
- Calendar works as an agenda where the user can plan the daily work and receive personalized alerts for each task.
- SoloMio lets the user group the favorite functions in the homepage for immediate access.
- With Match function the Oven and the Blast Chiller are connected to each other and communicate in order to guide the user through the cook&chill process optimizing time and efficiency (requires optional accessory).

Sustainability

- Holding at +3 °C for chilling or -22 °C for freezing, automatically activated at the end of each cycle, to save energy and maintain the target temperature (manual activation is also possible).
- Zero Waste provides chefs with useful tips for minimizing food waste.
Zero Waste is a library of Automatic recipes that aims to:
give a second life to raw food close to expiration date (e. g.: from milk to yogurt)
obtain genuine and tasty dishes from overripe fruit/vegetables (usually considered not appropriate for sale)
promote the use of typically discarded food items (e.g.: carrot peels).

Included Accessories



Rapido
Blast Chiller-Freezer 6GN1/1 30/30 kg for tower installation

The company reserves the right to make modifications to the products without prior notice. All information correct at time of printing.

Front

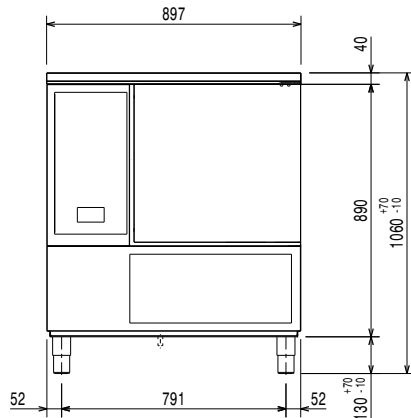

Side

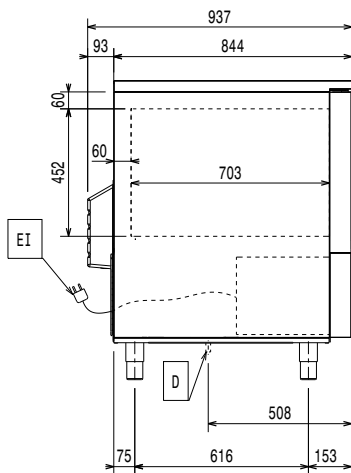

D = Drain
EI = Electrical inlet (power)

Top

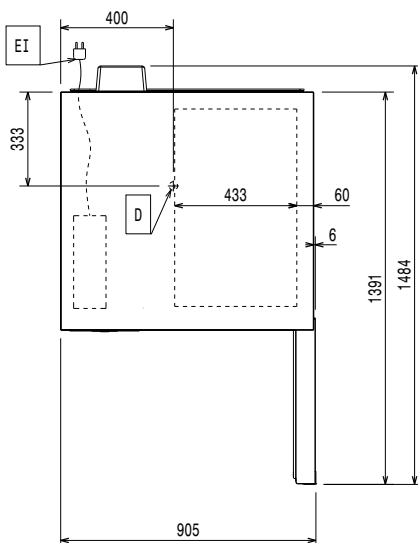

Electric

Supply voltage:
110545 (ZBFA61WE) 380-415 V/3N ph/50 Hz
Electrical power max.: 2.7 kW
Heating power: 1 kW
Circuit breaker required

Water:

Drain line size: 1"1/2
Pressure, bar min: 0

Installation:

Clearance: 5 cm on sides and back.
Please see and follow detailed installation instructions provided with the unit

Capacity:

Max load capacity: 30 kg
Trays type: 600x400; GN 1/1; Ice Cream

Key Information:

[NOT TRANSLATED] Right Side
External dimensions, Width: 897 mm
External dimensions, Depth: 937 mm
External dimensions, Height: 1020 mm
Net weight: 169 kg
Shipping weight: 184 kg
Shipping volume: 1.29 m³

Refrigeration Data

Built-in Compressor and Refrigeration Unit
Refrigeration power at evaporation temperature: -20 °C
[NOT TRANSLATED] AIR

Product Information (EN17032 – Commission Regulation EU 2015/1095)

Chilling Cycle Time (+65°C to +10°C): 74 min
Full load capacity (chilling): 30 kg
Freezing Cycle Time (+65°C to -18°C): 264 min
Full load capacity (freezing): 30 kg

Test performed in a test room at 30°C to chill/ freeze (+10°C/-18°C) a full load of 40mm deep trays filled with mashed potatoes evenly distributed up to a height of 35 mm at starting temperature between 65° and 80°C within 120/270min.

Sustainability

Refrigerant type: R452A
GWP Index: 2141
Refrigeration power: 2970 W
Refrigerant weight: 1150 g
Energy consumption, cycle (chilling): 0.0921 kWh/kg
Energy consumption, cycle (freezing): 0.2253 kWh/kg
Water consumption: 0 lt/hr