

Magistar Combi TI Natural Gas Combi Oven 10GN2/1

ITEM # _____

MODEL # _____

NAME # _____

SIS # _____

AIA # _____



218673 (ZCOG102K2U0) Magistar Combi TI combi boilerless oven with touch screen control, 10x2/1GN, gas, 2 cooking modes (recipe program, manual), automatic cleaning (Australia)

Short Form Specification

Item No.

- Combi oven with digital interface with guided selection.
- Built-in steam generator with real humidity control based upon Lambda Sensor.
 - AirFlow air distribution system to achieve maximum performance with 5 fan speed levels.
 - HP Automatic Cleaning: Automatic and built-in self cleaning system with integrated descale of the steam generator. 5 automatic cycles (soft, medium, strong, extra strong, rinse-only).
 - Cooking modes: Programs (a maximum of 100 recipes can be stored); Manual (steam, combi and convection cycles); EcoDelta cooking cycle; Regeneration cycle.
 - Automatic backup mode to avoid downtime.
 - USB port to download HACCP data, programs and settings. Connectivity ready.
 - Single sensor core temperature probe.
 - Double-glass door with LED lights.
 - Stainless steel construction throughout.
 - Supplied with n.1 tray rack 2/1 GN, 67 mm pitch.

Main Features

- Boilerless steaming function to add and retain moisture for high quality, consistent cooking results.
- Dry hot convection cycle (max 300 °C) ideal for low humidity cooking. Automatic moistener (11 settings) for boiler-less steam generation.
- EcoDelta cooking: cooking with food probe maintaining preset temperature difference between the core of the food and the cooking chamber.
- Programs mode: a maximum of 1000 recipes can be stored in the oven's memory, to recreate the exact same recipe at any time. The recipes can be group in 16 different categories to better organize the menu. 16-step cooking programs also available.
- MultiTimer function to manage up to 20 different cooking cycles at the same time, improving flexibility and ensuring excellent cooking results. Can be saved up to 200 MultiTimer programs.
- AirFlow air distribution system to achieve maximum performance in chilling/heating evenness and temperature control thanks to a special design of the chamber combined with high precision variable speed fan.
- Fan with 7 speed levels from 300 to 1500 RPM and reverse rotation for optimal evenness. Fan stops in less than 5 seconds when door is opened.
- Single sensor core temperature probe included.
- Pictures upload for full customization of cooking cycles.
- Automatic fast cool down and pre-heat function.
- Grease Collector: predisposed for integrated grease drain and collection for safer operation (dedicated base as optional accessory).
- Back-up mode with self-diagnosis is automatically activated if a failure occurs to avoid downtime.
- 2 different chemical options available: solid and liquid (requires optional accessory).
- Capacity: 10 GN 2/1 or 20 GN 1/1 trays.
- [NOT TRANSLATED]

Construction

- Double thermo-glazed door with open frame construction, for cool outside door panel. Swing hinged easy-release inner glass on door for easy cleaning.
- Seamless hygienic internal chamber with all rounded corners for easy cleaning.
- 304 AISI stainless steel construction throughout.
- Front access to control board for easy service.
- IPX 5 spray water protection certification for easy cleaning.
- Supplied with n.1 tray rack 2/1 GN, 67 mm pitch.

User Interface & Data Management

- High resolution full touch screen interface (translated in more than 30 languages) - color-blind friendly panel.
- Make-it-mine feature to allow full personalization or locking of the user interface.
- SoloMio lets the user group the favorite functions in

APPROVAL:

the homepage for immediate access.

- Calendar works as an agenda where the user can plan the daily work and receive personalized alerts for each task.
- USB port to download HACCP data, share cooking programs and configurations. USB port also allows to plug-in sous-vide probe (optional accessory).
- Connectivity ready for real time access to connected appliances from remote and HACCP monitoring (requires optional accessory).
- Trainings and guidances supporting materials easily accessible by scanning QR-Code with any mobile device.
- Automatic consumption visualization at the end of the cycle.

Sustainability

- Reduced power function for customized slow cooking cycles.
- HP Automatic Cleaning: Automatic and built-in self cleaning system. 5 automatic cycles (soft, medium, strong, extra strong, rinse-only) and green functions to save energy, water, detergent and rinse aid. Also programmable with delayed start.
- Cooking Optimizer function organizes the cooking sequence of the chosen cycles optimizing the work in the kitchen from a time and energy efficiency point of view.

Optional Accessories

- Water softener with cartridge and flow meter (high steam usage) PNC 920003
- Wheel kit for 6 & 10 GN 1/1 and 2/1 GN oven base (not for the disassembled one) PNC 922003
- Pair of AISI 304 stainless steel grids, GN 1/1 PNC 922017
- Pair of grids for whole chicken (8 per grid - 1,2kg each), GN 1/1 PNC 922036
- AISI 304 stainless steel grid, GN 1/1 PNC 922062
- AISI 304 stainless steel grid, GN 2/1 PNC 922076
- External side spray unit (needs to be mounted outside and includes support to be mounted on the oven) PNC 922171
- Pair of AISI 304 stainless steel grids, GN 2/1 PNC 922175
- Baking tray for 5 baguettes in perforated aluminum with silicon coating, 400x600x38mm PNC 922189
- Baking tray with 4 edges in perforated aluminum, 400x600x20mm PNC 922190
- Baking tray with 4 edges in aluminum, 400x600x20mm PNC 922191
- Pair of frying baskets PNC 922239
- AISI 304 stainless steel bakery/pastry grid 400x600mm PNC 922264
- Double-step door opening kit PNC 922265
- Grid for whole chicken (8 per grid - 1,2kg each), GN 1/1 PNC 922266
- USB probe for sous-vide cooking PNC 922281
- Kit universal skewer rack and 6 short skewers for Lengthwise GN 2/1 and Crosswise ovens PNC 922325
- Universal skewer rack PNC 922326
- 6 short skewers PNC 922328
- Multipurpose hook PNC 922348
- 4 flanged feet for 6 & 10 GN , 2", 100-130mm PNC 922351

- Grease collection tray, GN 2/1, H=60 mm PNC 922357
- Grid for whole duck (8 per grid - 1,8kg each), GN 1/1 PNC 922362
- Thermal cover for 10 GN 2/1 oven and blast chiller freezer PNC 922366
- Tray support for 6 & 10 GN 2/1 disassembled open base PNC 922384
- Wall mounted detergent tank holder PNC 922386
- USB SINGLE POINT PROBE PNC 922390
- Tray rack with wheels 10 GN 2/1, 65mm pitch (std) PNC 922603
- Tray rack with wheels, 8 GN 2/1, 80mm pitch PNC 922604
- Slide-in rack with handle for 6 & 10 GN 2/1 oven PNC 922605
- Bakery/pastry tray rack with wheels 400x600mm for 10 GN 2/1 oven and blast chiller freezer, 80mm pitch (8 runners) PNC 922609
- Open base with tray support for 6 & 10 GN 2/1 oven PNC 922613
- External connection kit for detergent and rinse aid PNC 922618
- Stacking kit for gas 6 GN 2/1 oven placed on gas 10 GN 2/1 oven PNC 922625
- Trolley for slide-in rack for 6 & 10 GN 2/1 oven and blast chiller freezer PNC 922627
- Trolley for mobile rack for 6 GN 2/1 on 6 or 10 GN 2/1 ovens PNC 922631
- Stainless steel drain kit for 6 & 10 GN oven, dia=50mm PNC 922636
- Plastic drain kit for 6 & 10 GN oven, dia=50mm PNC 922637
- Trolley with 2 tanks for grease collection PNC 922638
- Grease collection kit for open base (2 tanks, open/close device and drain) PNC 922639
- Banquet rack with wheels holding 51 plates for 10 GN 2/1 oven and blast chiller freezer, 75mm pitch PNC 922650
- Dehydration tray, GN 1/1, H=20mm PNC 922651
- Flat dehydration tray, GN 1/1 PNC 922652
- Open base for 6 & 10 GN 2/1 oven, disassembled PNC 922654
- Heat shield for 10 GN 2/1 oven PNC 922664
- Heat shield-stacked for ovens 6 GN 2/1 on 10 GN 2/1 PNC 922667
- Kit to convert from natural gas to LPG PNC 922670
- Kit to convert from LPG to natural gas PNC 922671
- Flue condenser for gas oven PNC 922678
- Kit to fix oven to the wall PNC 922687
- 4 high adjustable feet for 6 & 10 GN ovens, 100-115MM PNC 922688
- Tray support for 6 & 10 GN 2/1 open base PNC 922692
- Detergent tank holder for open base PNC 922699
- Mesh grilling grid PNC 922713
- Probe holder for liquids PNC 922714
- 4 high adjustable feet for 6 & 10 GN ovens, 230-290mm PNC 922745
- Tray for traditional static cooking, H=100mm PNC 922746
- Double-face griddle, one side ribbed and one side smooth, 400x600mm PNC 922747

- TROLLEY FOR GREASE COLLECTION KIT PNC 922752
- Water inlet pressure reducer PNC 922773
- Non-stick universal pan, GN 1/1, H=20mm PNC 925000
- Non-stick universal pan, GN 1/1, H=40mm PNC 925001
- Non-stick universal pan, GN 1/1, H=60mm PNC 925002
- Double-face griddle, one side ribbed and one side smooth, GN 1/1 PNC 925003
- Aluminum grill, GN 1/1 PNC 925004
- Frying pan for 8 eggs, pancakes, hamburgers, GN 1/1 PNC 925005
- Flat baking tray with 2 edges, GN 1/1 PNC 925006
- Potato baker for 28 potatoes, GN 1/1 PNC 925008
- Compatibility kit for installation on previous base GN 2/1 PNC 930218

Front

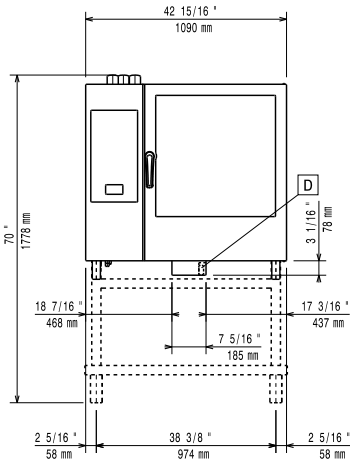

Side

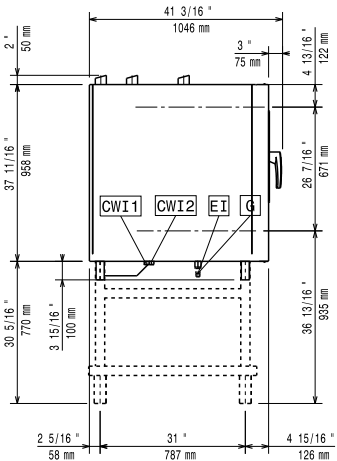

- C-WI-1** = Cold Water inlet 1 **EI** = Electrical inlet (power)
- C-WI-2** = Cold Water Inlet 2 **G** = Gas connection
- D** = Drain
- DO** = Overflow drain pipe

Top

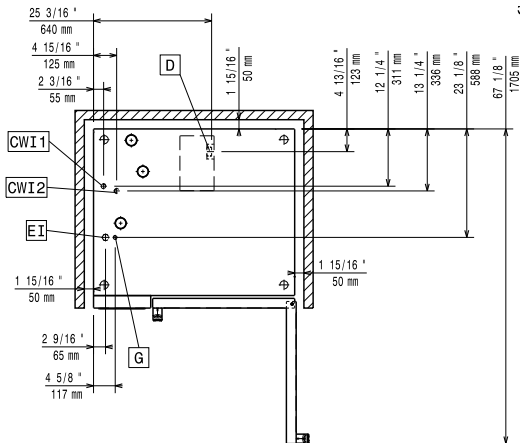

Electric

Circuit breaker required

Supply voltage: 230-240 V/1 ph/50 Hz
Electrical power max.: 1.5 kW
Electrical power, default: 1.5 kW

Gas

Total thermal load: 129542 BTU (38 kW)
Gas Power: 38 kW
Standard gas delivery: Natural Gas G20
ISO 7/1 gas connection diameter: 1/2" MNPT

Water:

Max inlet water supply temperature: 30 °C
Water inlet "FCW" connection: 3/4"
Pressure, bar min/max: 1-6 bar
Chlorides: <10 ppm
Conductivity: >50 µS/cm
Drain "D": 50mm

Electrolux Professional recommends the use of treated water, based on testing of specific water conditions.

Please refer to user manual for detailed water quality information.

Installation:

Clearance: Clearance: 5 cm rear and right hand sides.
Suggested clearance for service access: 50 cm left hand side.

Capacity:

GN: 10 - 2/1 Gastronom
Max load capacity: 100 kg

Key Information:

Door hinges: Right Side
External dimensions, Width: 1090 mm
External dimensions, Depth: 971 mm
External dimensions, Height: 1058 mm
Weight: 182.5 kg
Net weight: 182.5 kg
Shipping weight: 207.5 kg
Shipping volume: 1.58 m³