

# Magistar Combi TI Natural Gas Combi Oven 20GN2/1

ITEM # \_\_\_\_\_

MODEL # \_\_\_\_\_

NAME # \_\_\_\_\_

SIS # \_\_\_\_\_

AIA # \_\_\_\_\_



**218675 (ZCOG202K2U0)** Magistar Combi TI combi boilerless oven with touch screen control, 20x2/1GN, gas, 2 cooking modes (recipe program, manual), automatic cleaning (Australia)

## Short Form Specification

### Item No.

- Combi oven with digital interface with guided selection.
- Built-in steam generator with real humidity control based upon Lambda Sensor.
  - AirFlow air distribution system to achieve maximum performance with 5 fan speed levels.
  - HP Automatic Cleaning: Automatic and built-in self cleaning system with integrated descale of the steam generator. 5 automatic cycles (soft, medium, strong, extra strong, rinse-only).
  - Cooking modes: Programs (a maximum of 100 recipes can be stored); Manual (steam, combi and convection cycles); EcoDelta cooking cycle; Regeneration cycle.
  - Automatic backup mode to avoid downtime.
  - USB port to download HACCP data, programs and settings. Connectivity ready.
  - Single sensor core temperature probe.
  - Double-glass door with LED lights.
  - Stainless steel construction throughout.
  - Supplied with n.1 trolley rack 2/1 GN, 63 mm pitch.

## Main Features

- Boilerless steaming function to add and retain moisture for high quality, consistent cooking results.
- Dry hot convection cycle (max 300 °C) ideal for low humidity cooking. Automatic moistener (11 settings) for boiler-less steam generation.
- EcoDelta cooking: cooking with food probe maintaining preset temperature difference between the core of the food and the cooking chamber.
- Programs mode: a maximum of 1000 recipes can be stored in the oven's memory, to recreate the exact same recipe at any time. The recipes can be group in 16 different categories to better organize the menu. 16-step cooking programs also available.
- MultiTimer function to manage up to 20 different cooking cycles at the same time, improving flexibility and ensuring excellent cooking results. Can be saved up to 200 MultiTimer programs.
- AirFlow air distribution system to achieve maximum performance in chilling/heating evenness and temperature control thanks to a special design of the chamber combined with high precision variable speed fan.
- Fan with 7 speed levels from 300 to 1500 RPM and reverse rotation for optimal evenness. Fan stops in less than 5 seconds when door is opened.
- Single sensor core temperature probe included.
- Pictures upload for full customization of cooking cycles.
- Automatic fast cool down and pre-heat function.
- Back-up mode with self-diagnosis is automatically activated if a failure occurs to avoid downtime.
- 2 different chemical options available: solid and liquid (requires optional accessory).
- Capacity: 20 GN 2/1 or 40 GN 1/1 trays.
- [NOT TRANSLATED]

## Construction

- Double thermo-glazed door with open frame construction, for cool outside door panel. Swing hinged easy-release inner glass on door for easy cleaning.
- Seamless hygienic internal chamber with all rounded corners for easy cleaning.
- 304 AISI stainless steel construction throughout.
- Front access to control board for easy service.
- IPX 5 spray water protection certification for easy cleaning.
- Integrated door shield to avoid steam and heat dispersion from the door, when the roll-in rack is not used.
- Supplied with n.1 trolley rack 2/1 GN, 63 mm pitch.

## User Interface & Data Management

- High resolution full touch screen interface (translated in more than 30 languages) - color-blind friendly panel.
- Make-it-mine feature to allow full personalization or locking of the user interface.
- SoloMio lets the user group the favorite functions in

**APPROVAL:** \_\_\_\_\_

the homepage for immediate access.

- Calendar works as an agenda where the user can plan the daily work and receive personalized alerts for each task.
- USB port to download HACCP data, share cooking programs and configurations. USB port also allows to plug-in sous-vide probe (optional accessory).
- Connectivity ready for real time access to connected appliances from remote and HACCP monitoring (requires optional accessory).
- Trainings and guidances supporting materials easily accessible by scanning QR-Code with any mobile device.
- Automatic consumption visualization at the end of the cycle.

## Sustainability

- Reduced power function for customized slow cooking cycles.
- HP Automatic Cleaning: Automatic and built-in self cleaning system. 5 automatic cycles (soft, medium, strong, extra strong, rinse-only) and green functions to save energy, water, detergent and rinse aid. Also programmable with delayed start.
- Cooking Optimizer function organizes the cooking sequence of the chosen cycles optimizing the work in the kitchen from a time and energy efficiency point of view.

## Included Accessories

- 1 of Trolley with tray rack 20 GN 2/1, 63mm pitch (included) PNC 922757

## Optional Accessories

- Water softener with cartridge and flow meter (high steam usage) PNC 920003
- Pair of AISI 304 stainless steel grids, GN 1/1 PNC 922017
- Pair of grids for whole chicken (8 per grid - 1,2kg each), GN 1/1 PNC 922036
- AISI 304 stainless steel grid, GN 1/1 PNC 922062
- External side spray unit (needs to be mounted outside and includes support to be mounted on the oven) PNC 922171
- Baking tray for 5 baguettes in perforated aluminum with silicon coating, 400x600x38mm PNC 922189
- Baking tray with 4 edges in perforated aluminum, 400x600x20mm PNC 922190
- Baking tray with 4 edges in aluminum, 400x600x20mm PNC 922191
- Pair of frying baskets PNC 922239
- AISI 304 stainless steel bakery/pastry grid 400x600mm PNC 922264
- Grid for whole chicken (8 per grid - 1,2kg each), GN 1/1 PNC 922266
- USB probe for sous-vide cooking PNC 922281
- Universal skewer rack PNC 922326
- 6 short skewers PNC 922328
- Smoker for lengthwise and crosswise oven (4 kinds of smoker wood chips are available on request) PNC 922338
- Multipurpose hook PNC 922348
- Grease collection tray, GN 2/1, H=60 mm PNC 922357
- Grid for whole duck (8 per grid - 1,8kg each), GN 1/1 PNC 922362

- Thermal cover for 20 GN 2/1 oven and blast chiller freezer PNC 922367
- Wall mounted detergent tank holder PNC 922386
- USB SINGLE POINT PROBE PNC 922390
- External connection kit for detergent and rinse aid PNC 922618
- Dehydration tray, GN 1/1, H=20mm PNC 922651
- Flat dehydration tray, GN 1/1 PNC 922652
- Heat shield for 20 GN 2/1 oven PNC 922658
- Kit to convert from natural gas to LPG PNC 922670
- Kit to convert from LPG to natural gas PNC 922671
- Flue condenser for gas oven PNC 922678
- Trolley with tray rack, 16 GN 2/1, 84mm pitch PNC 922686
- Kit to fix oven to the wall PNC 922687
- 4 flanged feet for 20 GN , 2", 150mm PNC 922707
- Mesh grilling grid PNC 922713
- Probe holder for liquids PNC 922714
- Tray for traditional static cooking, H=100mm PNC 922746
- Double-face griddle, one side ribbed and one side smooth, 400x600mm PNC 922747
- Trolley with tray rack 20 GN 2/1, 63mm pitch (included) PNC 922757
- Trolley with tray rack, 16 GN 2/1, 80mm pitch PNC 922758
- Banquet trolley with rack holding 92 plates for 20 GN 2/1 oven and blast chiller freezer, 85mm pitch PNC 922760
- Bakery/pastry trolley with rack holding 400x600mm grids for 20 GN 2/1 oven and blast chiller freezer, 80mm pitch (16 runners) PNC 922762
- Banquet trolley with rack holding 116 plates for 20 GN 2/1 oven and blast chiller freezer, 66mm pitch PNC 922764
- Kit compatibility for aos/easyline trolley (produced till 2019) with SkyLine/Magistar 20 GN 2/1 combi oven PNC 922770
- Kit compatibility for aos/easyline 20 GN oven with SkyLine/Magistar trolleys PNC 922771
- Water inlet pressure reducer PNC 922773
- Non-stick universal pan, GN 1/ 1, H=40mm PNC 925001
- Non-stick universal pan, GN 1/1, H=60mm PNC 925002
- Double-face griddle, one side ribbed and one side smooth, GN 1/1 PNC 925003
- Aluminum grill, GN 1/1 PNC 925004
- Frying pan for 8 eggs, pancakes, hamburgers, GN 1/1 PNC 925005
- Flat baking tray with 2 edges, GN 1/1 PNC 925006
- Potato baker for 28 potatoes, GN 1/1 PNC 925008

**Front**

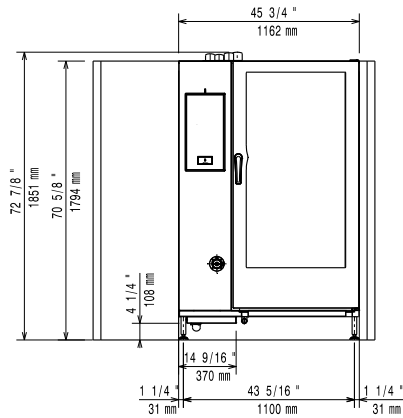

**Side**

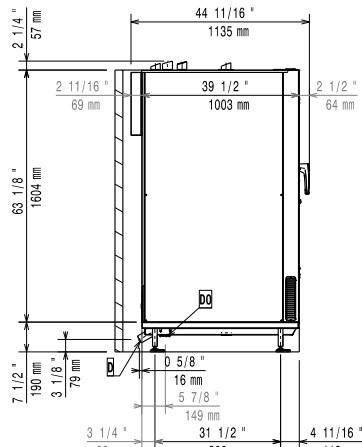

- C-1** = Cold Water inlet 1      **EI** = Electrical inlet (power)
- WI-1**
- C-2** = Cold Water Inlet 2      **G** = Gas connection
- WI-2**
- D** = Drain
- DO** = Overflow drain pipe

**Top**

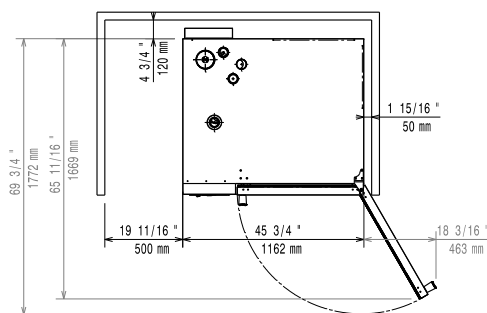

**Electric**

**Circuit breaker required**

**Supply voltage:** 230-240 V/1 ph/50 Hz  
**Electrical power max.:** 2.5 kW  
**Electrical power, default:** 2.5 kW

**Gas**

**Total thermal load:** 259084 BTU (76 kW)  
**Gas Power:** 76 kW  
**Standard gas delivery:** Natural Gas G20  
**ISO 7/1 gas connection diameter:** 1" MNPT

**Water:**

**Max inlet water supply temperature:** 30 °C

**Water inlet "FCW" connection:** 3/4"  
**Pressure, bar min/max:** 1-6 bar  
**Chlorides:** <10 ppm  
**Conductivity:** >50 µS/cm  
**Drain "D":** 50mm

*Electrolux Professional* recommends the use of treated water, based on testing of specific water conditions.

Please refer to user manual for detailed water quality information.

**Installation:**

**Clearance:** Clearance: 5 cm rear and right hand sides.  
**Suggested clearance for service access:** 50 cm left hand side.

**Capacity:**

**GN:** 20 - 2/1 Gastronom  
**Max load capacity:** 200 kg

**Key Information:**

**Door hinges:** Right Side  
**External dimensions, Width:** 1162 mm  
**External dimensions, Depth:** 1066 mm  
**External dimensions, Height:** 1794 mm  
**Weight:** 345.5 kg  
**Net weight:** 345.5 kg  
**Shipping weight:** 383.5 kg  
**Shipping volume:** 2.77 m<sup>3</sup>