

Magistar Combi TS Natural Gas Combi Oven 6GN2/1

ITEM # _____

MODEL # _____

NAME # _____

SIS # _____

AIA # _____



218771 (ZCOG62T2U0) Magistar Combi TS combi boiler oven with touch screen control, 6x2/1 GN, gas, 3 cooking modes (automatic, recipe program, manual), automatic cleaning, boiler in AISI304 (Australia)

Short Form Specification

Item No.

- Combi oven with high resolution full touch screen interface, multilanguage.
- Boilerless steaming function to add and retain moisture.
 - AirFlow air distribution system to achieve maximum performance with 7 fan speed levels.
 - HP Automatic Cleaning: Automatic and built-in self cleaning system. 5 automatic cycles (soft, medium, strong, extra strong, rinse-only) and economizer functions to save energy, water, detergent and rinse aid.
 - Cooking modes: Programs (a maximum of 1000 recipes can be stored and organized in 16 different categories); Manual (steam, combi and convection cycles); EcoDelta cooking cycle.
 - Special functions: MultiTimer cooking, Cooking Optimizer to cut running costs, Make-it-Mine to customize interface, SoloMio to customize homepage, agenda Calendar, automatic backup mode to avoid downtime.
 - USB port to download HACCP data, programs and settings. Connectivity ready.
 - Single sensor core temperature probe.
 - Double-glass door with LED lights.
 - Stainless steel construction throughout.
 - Supplied with n.1 tray rack 2/1 GN, 67 mm pitch.

Main Features

- Built-in steam generator for highly precise humidity and temperature control according to the chosen settings.
- Real humidity control based upon Lambda Sensor to automatically recognize quantity and size of food for consistent quality results.
- Dry, hot convection cycle (25 °C - 300 °C): ideal for low humidity cooking.
- Combination cycle (25 °C - 300 °C): combining convected heat and steam to obtain humidity controlled cooking environment, accelerating the cooking process and reducing weight loss.
- Low temperature Steam cycle (25 °C - 99 °C): ideal for sous-vide, re-thermalization and delicate cooking. Steam cycle (100 °C): seafood and vegetables. High temperature steam (25 °C - 130 °C).
- Automatic mode including 9 food families (meat, poultry, fish, vegetables, pasta/rice, eggs, savory and sweet bakery, bread, dessert) with 100+ different pre-installed variants. Through Automatic Sensing Phase the oven optimizes the cooking process according to size, quantity and type of food loaded to achieve the selected cooking result. Real time overview of the cooking parameters. Possibility to personalize and save up to 70 variants per family.
- Special Cycles: - Regeneration (ideal for banqueting on plate or rethermalizing on tray), - Low Temperature Cooking (to minimize weight loss and maximize food quality), - Proving cycle, - EcoDelta cooking, cooking with food probe maintaining preset temperature difference between the core of the food and the cooking chamber, - Sous-vide cooking, - Static Combi (to reproduce traditional cooking from static oven), - Pasteurization of pasta, - Dehydration cycles (ideal for drying fruits, vegetables, meats, seafood), - Food Safe Control (to automatically monitor safety of cooking process in compliance with HACCP hygienic standards), - Advanced Food Safe Control (to drive the cooking with pasteurization factor).
- Programs mode: a maximum of 1000 recipes can be stored in the oven's memory, to recreate the exact same recipe at any time. The recipes can be group in 16 different categories to better organize the menu. 16-step cooking programs also available.
- MultiTimer function to manage up to 20 different cooking cycles at the same time, improving flexibility and ensuring excellent cooking results. Can be saved up to 200 MultiTimer programs.
- AirFlow air distribution system to achieve maximum performance in chilling/heating evenness and temperature control thanks to a special design of the chamber combined with high precision variable speed fan.
- Fan with 7 speed levels from 300 to 1500 RPM and reverse rotation for optimal evenness. Fan stops in less than 5 seconds when door is opened.
- 6-point multi sensor core temperature probe for maximum precision and food safety.
- Pictures upload for full customization of cooking cycles.
- Automatic fast cool down and pre-heat function.
- Grease Collector: predisposed for integrated grease

APPROVAL:

drain and collection for safer operation (dedicated base as optional accessory).

- USB port to download HACCP data, share cooking programs and configurations. USB port also allows to plug-in sous-vide probe (optional accessory).
- Back-up mode with self-diagnosis is automatically activated if a failure occurs to avoid downtime.
- 2 different chemical options available: solid and liquid (requires optional accessory).
- Capacity: 6 GN 2/1 or 12 GN 1/1 trays.
- [NOT TRANSLATED]

Construction

- Double thermo-glazed door with open frame construction, for cool outside door panel. Swing hinged easy-release inner glass on door for easy cleaning.
- Seamless hygienic internal chamber with all rounded corners for easy cleaning.
- 304 AISI stainless steel construction throughout.
- Front access to control board for easy service.
- Integrated spray gun with automatic retracting system for fast rinsing.
- IPX 5 spray water protection certification for easy cleaning.
- Supplied with n.1 tray rack 2/1 GN, 67 mm pitch.

User Interface & Data Management

- High resolution full touch screen interface (translated in more than 30 languages) - color-blind friendly panel.
- Make-it-mine feature to allow full personalization or locking of the user interface.
- SoloMio lets the user group the favorite functions in the homepage for immediate access.
- Calendar works as an agenda where the user can plan the daily work and receive personalized alerts for each task.
- Connectivity ready for real time access to connected appliances from remote and HACCP monitoring (requires optional accessory).
- Trainings and guidances supporting materials easily accessible by scanning QR-Code with any mobile device.
- Automatic consumption visualization at the end of the cycle.
- Connectivity ready for real time access to connected appliances from remote and data monitoring (requires optional accessory – contact the Company for more details).

Sustainability

- Reduced power function for customized slow cooking cycles.
- HP Automatic Cleaning: Automatic and built-in self cleaning system with integrated descale of the steam generator. 5 automatic cycles (soft, medium, strong, extra strong, rinse-only) and green functions to save energy, water, detergent and rinse aid. Also programmable with delayed start.
- Cooking Optimizer function organizes the cooking sequence of the chosen cycles optimizing the work in the kitchen from a time and energy efficiency point of view.

Optional Accessories

- Water softener with cartridge and flow meter (high steam usage) PNC 920003
- Water softener with salt for ovens with automatic regeneration of resin PNC 921305
- Wheel kit for 6 & 10 GN 1/1 and 2/1 GN oven base (not for the disassembled one) PNC 922003

- Pair of AISI 304 stainless steel grids, GN 1/1 PNC 922017
- Pair of grids for whole chicken (8 per grid - 1,2kg each), GN 1/1 PNC 922036
- AISI 304 stainless steel grid, GN 1/1 PNC 922062
- AISI 304 stainless steel grid, GN 2/1 PNC 922076
- External side spray unit (needs to be mounted outside and includes support to be mounted on the oven) PNC 922171
- Pair of AISI 304 stainless steel grids, GN 2/1 PNC 922175
- Baking tray for 5 baguettes in perforated aluminum with silicon coating, 400x600x38mm PNC 922189
- Baking tray with 4 edges in perforated aluminum, 400x600x20mm PNC 922190
- Baking tray with 4 edges in aluminum, 400x600x20mm PNC 922191
- Pair of frying baskets PNC 922239
- AISI 304 stainless steel bakery/pastry grid 400x600mm PNC 922264
- Double-step door opening kit PNC 922265
- Grid for whole chicken (8 per grid - 1,2kg each), GN 1/1 PNC 922266
- USB probe for sous-vide cooking PNC 922281
- Kit universal skewer rack and 6 short skewers for Lengthwise GN 2/1 and Crosswise ovens PNC 922325
- Universal skewer rack PNC 922326
- 6 short skewers PNC 922328
- Smoker for lengthwise and crosswise oven (4 kinds of smoker wood chips are available on request) PNC 922338
- Multipurpose hook PNC 922348
- 4 flanged feet for 6 & 10 GN , 2", 100-130mm PNC 922351
- Grease collection tray, GN 2/1, H=60 mm PNC 922357
- Grid for whole duck (8 per grid - 1,8kg each), GN 1/1 PNC 922362
- Tray support for 6 & 10 GN 2/1 disassembled open base PNC 922384
- Wall mounted detergent tank holder PNC 922386
- USB SINGLE POINT PROBE PNC 922390
- Slide-in rack with handle for 6 & 10 GN 2/1 oven PNC 922605
- Tray rack with wheels, 5 GN 2/1, 80mm pitch PNC 922611
- Open base with tray support for 6 & 10 GN 2/1 oven PNC 922613
- Cupboard base with tray support for 6 & 10 GN 2/1 oven PNC 922616
- Hot cupboard base with tray support for 6 & 10 GN 2/1 oven holding GN 1/1 or 400x600mm PNC 922617
- External connection kit for detergent and rinse aid PNC 922618
- Stacking kit for gas 6X2/1 GN oven on gas 6&10X2/1 GN oven PNC 922624
- Stacking kit for gas 6 GN 2/1 oven placed on gas 10 GN 2/1 oven PNC 922625
- Trolley for slide-in rack for 6 & 10 GN 2/1 oven and blast chiller freezer PNC 922627

- | | | | | | |
|--|------------|--------------------------|--|------------|--------------------------|
| • Trolley for mobile rack for 2 stacked 6 GN 2/1 ovens on riser | PNC 922629 | <input type="checkbox"/> | • Frying pan for 8 eggs, pancakes, hamburgers, GN 1/1 | PNC 925005 | <input type="checkbox"/> |
| • Trolley for mobile rack for 6 GN 2/1 on 6 or 10 GN 2/1 ovens | PNC 922631 | <input type="checkbox"/> | • Flat baking tray with 2 edges, GN 1/1 | PNC 925006 | <input type="checkbox"/> |
| • Riser on feet for stacked 2x6 GN 1/1 ovens | PNC 922633 | <input type="checkbox"/> | • Potato baker for 28 potatoes, GN 1/1 | PNC 925008 | <input type="checkbox"/> |
| • Riser on wheels for stacked 2x6 GN 2/1 ovens, height 250mm | PNC 922634 | <input type="checkbox"/> | • Compatibility kit for installation on previous base GN 2/1 | PNC 930218 | <input type="checkbox"/> |
| • Stainless steel drain kit for 6 & 10 GN oven, dia=50mm | PNC 922636 | <input type="checkbox"/> | | | |
| • Plastic drain kit for 6 & 10 GN oven, dia=50mm | PNC 922637 | <input type="checkbox"/> | | | |
| • Trolley with 2 tanks for grease collection | PNC 922638 | <input type="checkbox"/> | | | |
| • Grease collection kit for open base (2 tanks, open/close device and drain) | PNC 922639 | <input type="checkbox"/> | | | |
| • Wall support for 6 GN 2/1 oven | PNC 922644 | <input type="checkbox"/> | | | |
| • Dehydration tray, GN 1/1, H=20mm | PNC 922651 | <input type="checkbox"/> | | | |
| • Flat dehydration tray, GN 1/1 | PNC 922652 | <input type="checkbox"/> | | | |
| • Open base for 6 & 10 GN 2/1 oven, disassembled | PNC 922654 | <input type="checkbox"/> | | | |
| • Heat shield for 6 GN 2/1 oven | PNC 922665 | <input type="checkbox"/> | | | |
| • Heat shield-stacked for ovens 6 GN 2/1 on 6 GN 2/1 | PNC 922666 | <input type="checkbox"/> | | | |
| • Heat shield-stacked for ovens 6 GN 2/1 on 10 GN 2/1 | PNC 922667 | <input type="checkbox"/> | | | |
| • Kit to convert from natural gas to LPG | PNC 922670 | <input type="checkbox"/> | | | |
| • Kit to convert from LPG to natural gas | PNC 922671 | <input type="checkbox"/> | | | |
| • Flue condenser for gas oven | PNC 922678 | <input type="checkbox"/> | | | |
| • Fixed tray rack, 5 GN 2/1, 85mm pitch | PNC 922681 | <input type="checkbox"/> | | | |
| • Kit to fix oven to the wall | PNC 922687 | <input type="checkbox"/> | | | |
| • 4 high adjustable feet for 6 & 10 GN ovens, 100-115MM | PNC 922688 | <input type="checkbox"/> | | | |
| • Tray support for 6 & 10 GN 2/1 open base | PNC 922692 | <input type="checkbox"/> | | | |
| • Detergent tank holder for open base | PNC 922699 | <input type="checkbox"/> | | | |
| • Tray rack with wheels, 6 GN 2/1, 65mm pitch (included) | PNC 922700 | <input type="checkbox"/> | | | |
| • CHIMNEY ADAPTOR NEEDED IN CASE OF CONVERSION OF 6 GN 1/1 OR 6 GN 2/1 OVENS FROM NATURAL GAS TO LPG | PNC 922706 | <input type="checkbox"/> | | | |
| • Mesh grilling grid | PNC 922713 | <input type="checkbox"/> | | | |
| • Probe holder for liquids | PNC 922714 | <input type="checkbox"/> | | | |
| • 4 high adjustable feet for 6 & 10 GN ovens, 230-290mm | PNC 922745 | <input type="checkbox"/> | | | |
| • Tray for traditional static cooking, H=100mm | PNC 922746 | <input type="checkbox"/> | | | |
| • Double-face griddle, one side ribbed and one side smooth, 400x600mm | PNC 922747 | <input type="checkbox"/> | | | |
| • TROLLEY FOR GREASE COLLECTION KIT | PNC 922752 | <input type="checkbox"/> | | | |
| • Water inlet pressure reducer | PNC 922773 | <input type="checkbox"/> | | | |
| • Non-stick universal pan, GN 1/1, H=20mm | PNC 925000 | <input type="checkbox"/> | | | |
| • Non-stick universal pan, GN 1/ 1, H=40mm | PNC 925001 | <input type="checkbox"/> | | | |
| • Non-stick universal pan, GN 1/1, H=60mm | PNC 925002 | <input type="checkbox"/> | | | |
| • Double-face griddle, one side ribbed and one side smooth, GN 1/1 | PNC 925003 | <input type="checkbox"/> | | | |
| • Aluminum grill, GN 1/1 | PNC 925004 | <input type="checkbox"/> | | | |

Front

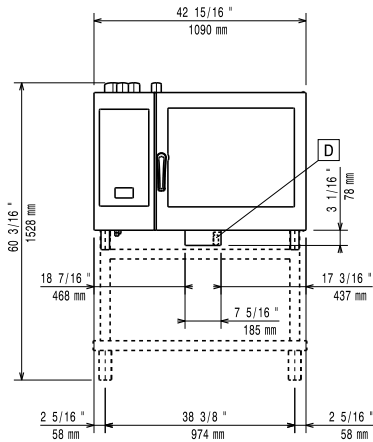

Side

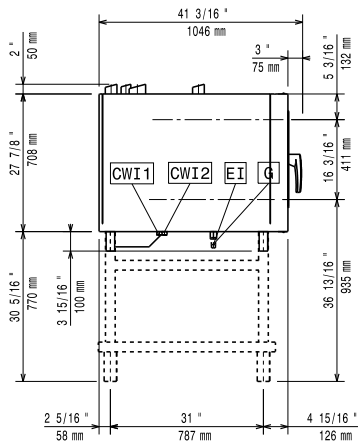

- C-** = Cold Water inlet 1
- WI-1**
- C-** = Cold Water Inlet 2
- WI-2**
- D** = Drain
- DO** = Overflow drain pipe
- EI** = Electrical inlet (power)
- G** = Gas connection

Top
59

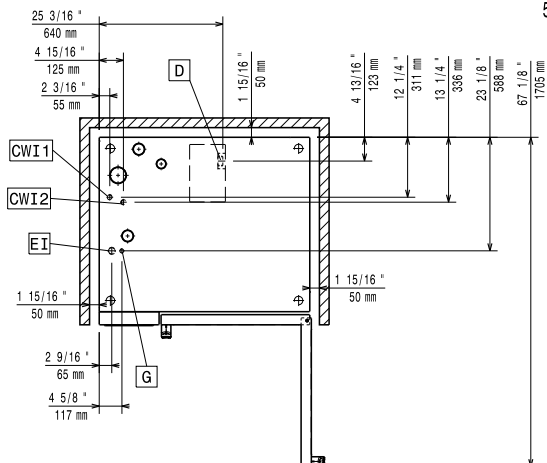

Electric

Supply voltage:
218771 (ZCOG62T2U0) 230-240 V/1 ph/50 Hz
Electrical power, default: 1.5 kW
Electrical power max.: 1.5 kW
Circuit breaker required

Gas

Gas Power: 34.8 kW
Standard gas delivery: Natural Gas G20
ISO 7/1 gas connection diameter: 1/2" MNPT
Total thermal load: 118633 BTU (34.8 kW)

Water:

Water inlet "FCW" connection: 3/4"
Pressure, bar min/max: 1-6 bar
Drain "D": 50mm
Max inlet water supply temperature: 30 °C
Chlorides: <17 ppm
Conductivity: >50 µS/cm
Electrolux Professional recommends the use of treated water, based on testing of specific water conditions.
Please refer to user manual for detailed water quality information.

Installation:

Clearance: Clearance: 5 cm rear and right hand sides.
Suggested clearance for service access: 50 cm left hand side.

Capacity:

GN: 6 - 2/1 Gastronorm
Max load capacity: 60 kg

Key Information:

Door hinges:
External dimensions, Width: 1090 mm
External dimensions, Depth: 971 mm
External dimensions, Height: 808 mm
Net weight: 173 kg
Shipping weight: 196 kg
Shipping volume: 1.27 m³