

Magistar Combi DS Electric Combi Oven 10GN1/1

ITEM # _____

MODEL # _____

NAME # _____

SIS # _____

AIA # _____



218832 (ZCOE101B2S0) Magistar Combi DS combi boiler oven with digital control, 10x1/1GN, electric, programmable, automatic cleaning, boiler in AISI304 (Australia)

Short Form Specification

Item No.

Combi oven with high resolution full touch screen interface, multilanguage

- Built-in steam generator with real humidity control based upon Lambda Sensor
- AirFlow air distribution system to achieve maximum performance with 7 fan speed levels
- HP Automatic Cleaning: Automatic and built-in self cleaning system with integrated descale of the steam generator. 5 automatic cycles (soft, medium, strong, extra strong, rinse-only) and economizer functions to save energy, water, detergent and rinse aid
- Cooking modes: Automatic (9 food families with 100+ different pre-installed variants); Programs (a maximum of 1000 recipes can be stored and organized in 16 different categories); Manual (steam, combi and convection cycles); Specialistic Cycles (regeneration, Low Temperature Cooking, proving, EcoDelta, Sous-Vide, Static-Combi, Pasteurization of pasta, dehydration, Food Safe Control and Advanced Food Safe Control)
- Special functions: MultiTimer cooking, Cooking Optimizer to cut running costs, Make-it-Mine to customize interface, SoloMio to customize homepage, agenda Calendar, automatic backup mode to avoid downtime
- USB port to download HACCP data, programs and settings. Connectivity ready
- 6-point multi sensor core temperature probe
- Double glass door with LED lights
- Stainless steel construction throughout
- Supplied with n.1 tray rack 1/1 GN, 67 mm pitch.

Main Features

- Digital interface with LED backlight buttons with guided selection.
- Built-in steam generator for highly precise humidity and temperature control according to the chosen settings.
- Real humidity control based upon Lambda Sensor to automatically recognize quantity and size of food for consistent quality results.
- Dry, hot convection cycle (25 °C - 300 °C): ideal for low humidity cooking.
- Combination cycle (25 °C - 300 °C): combining convected heat and steam to obtain humidity controlled cooking environment, accelerating the cooking process and reducing weight loss.
- Low temperature Steam cycle (25 °C - 99 °C): ideal for sous-vide, re-thermalization and delicate cooking. Steam cycle (100 °C): seafood and vegetables. High temperature steam (25 °C - 130 °C).
- EcoDelta cooking: cooking with food probe maintaining preset temperature difference between the core of the food and the cooking chamber.
- Pre-set program for Regeneration, ideal for banqueting on plate or rethermalizing on tray.
- Programs mode: a maximum of 100 recipes can be stored in the oven's memory, to recreate the exact same recipe at any time. 4-step cooking programs also available.
- AirFlow air distribution system to achieve maximum performance in chilling/heating evenness and temperature control thanks to a special design of the chamber combined with high precision variable speed fan.
- Fan with 5 speed levels from 300 to 1500 RPM and reverse rotation for optimal evenness. Fan stops in less than 5 seconds when door is opened.
- Single sensor core temperature probe included.
- Automatic fast cool down and pre-heat function.
- HP Automatic Cleaning: Automatic and built-in self cleaning system with integrated descale of the steam generator. 5 automatic cycles (soft, medium, strong, extra strong, rinse-only).
- Grease Collector: predisposed for integrated grease drain and collection for safer operation (dedicated base as optional accessory).
- USB port to download HACCP data, share cooking programs and configurations. USB port also allows to plug-in sous-vide probe (optional accessory).
- Back-up mode with self-diagnosis is automatically activated if a failure occurs to avoid downtime.
- 2 different chemical options available: solid and liquid (requires optional accessory).
- Capacity: 10 GN 1/1 trays.
- [NOT TRANSLATED]

Construction

- Double thermo-glazed door with open frame construction, for cool outside door panel. Swing hinged easy-release inner glass on door for easy cleaning.
- Seamless hygienic internal chamber with all rounded

APPROVAL:

- corners for easy cleaning.
- 304 AISI stainless steel construction throughout.
- Front access to control board for easy service.
- IPX 5 spray water protection certification for easy cleaning.
- Supplied with n.1 tray rack 1/1 GN, 67 mm pitch.

User Interface & Data Management

- Connectivity ready for real time access to connected appliances from remote and HACCP monitoring (requires optional accessory).
- Connectivity ready for real time access to connected appliances from remote and data monitoring (requires optional accessory – contact the Company for more details).

Sustainability

- Reduced power function for customized slow cooking cycles.

Optional Accessories

- | | | | | | |
|---|------------|--------------------------|---|------------|--------------------------|
| • Water softener with cartridge and flow meter (high steam usage) | PNC 920003 | <input type="checkbox"/> | • Tray support for 6 & 10 GN 1/1 disassembled open base | PNC 922382 | <input type="checkbox"/> |
| • Water softener with salt for ovens with automatic regeneration of resin | PNC 921305 | <input type="checkbox"/> | • Wall mounted detergent tank holder | PNC 922386 | <input type="checkbox"/> |
| • Wheel kit for 6 & 10 GN 1/1 and 2/1 GN oven base (not for the disassembled one) | PNC 922003 | <input type="checkbox"/> | • USB SINGLE POINT PROBE | PNC 922390 | <input type="checkbox"/> |
| • Pair of AISI 304 stainless steel grids, GN 1/1 | PNC 922017 | <input type="checkbox"/> | • Tray rack with wheels 10 GN 1/1, 65mm pitch (std) | PNC 922601 | <input type="checkbox"/> |
| • Pair of grids for whole chicken (8 per grid - 1,2kg each), GN 1/1 | PNC 922036 | <input type="checkbox"/> | • Tray rack with wheels, 8 GN 1/1, 80mm pitch | PNC 922602 | <input type="checkbox"/> |
| • AISI 304 stainless steel grid, GN 1/1 | PNC 922062 | <input type="checkbox"/> | • Bakery/pastry tray rack with wheels 400x600mm for 10 GN 1/1 oven and blast chiller freezer, 80mm pitch (8 runners) | PNC 922608 | <input type="checkbox"/> |
| • Grid for whole chicken (4 per grid - 1,2kg each), GN 1/2 | PNC 922086 | <input type="checkbox"/> | • Slide-in rack with handle for 6 & 10 GN 1/1 oven | PNC 922610 | <input type="checkbox"/> |
| • External side spray unit (needs to be mounted outside and includes support to be mounted on the oven) | PNC 922171 | <input type="checkbox"/> | • Open base with tray support for 6 & 10 GN 1/1 oven | PNC 922612 | <input type="checkbox"/> |
| • Baking tray for 5 baguettes in perforated aluminum with silicon coating, 400x600x38mm | PNC 922189 | <input type="checkbox"/> | • Cupboard base with tray support for 6 & 10 GN 1/1 oven | PNC 922614 | <input type="checkbox"/> |
| • Baking tray with 4 edges in perforated aluminum, 400x600x20mm | PNC 922190 | <input type="checkbox"/> | • Hot cupboard base with tray support for 6 & 10 GN 1/1 oven holding GN 1/1 or 400x600mm | PNC 922615 | <input type="checkbox"/> |
| • Baking tray with 4 edges in aluminum, 400x600x20mm | PNC 922191 | <input type="checkbox"/> | • External connection kit for detergent and rinse aid | PNC 922618 | <input type="checkbox"/> |
| • Pair of frying baskets | PNC 922239 | <input type="checkbox"/> | • Grease collection kit for GN 1/1-2/1 cupboard base (trolley with 2 tanks, open/close device and drain) | PNC 922619 | <input type="checkbox"/> |
| • AISI 304 stainless steel bakery/pastry grid 400x600mm | PNC 922264 | <input type="checkbox"/> | • Stacking kit for electric 6+6 GN 1/1 ovens or electric 6+10 GN 1/1 GN ovens | PNC 922620 | <input type="checkbox"/> |
| • Double-step door opening kit | PNC 922265 | <input type="checkbox"/> | • Trolley for slide-in rack for 6 & 10 GN 1/1 oven and blast chiller freezer | PNC 922626 | <input type="checkbox"/> |
| • Grid for whole chicken (8 per grid - 1,2kg each), GN 1/1 | PNC 922266 | <input type="checkbox"/> | • Trolley for mobile rack for 6 GN 1/1 on 6 or 10 GN 1/1 ovens | PNC 922630 | <input type="checkbox"/> |
| • Grease collection tray, GN 1/1, H=100 mm | PNC 922321 | <input type="checkbox"/> | • Stainless steel drain kit for 6 & 10 GN oven, dia=50mm | PNC 922636 | <input type="checkbox"/> |
| • Kit universal skewer rack and 4 long skewers for GN 1/1 ovens | PNC 922324 | <input type="checkbox"/> | • Plastic drain kit for 6 & 10 GN oven, dia=50mm | PNC 922637 | <input type="checkbox"/> |
| • Universal skewer rack | PNC 922326 | <input type="checkbox"/> | • Trolley with 2 tanks for grease collection | PNC 922638 | <input type="checkbox"/> |
| • 4 long skewers | PNC 922327 | <input type="checkbox"/> | • Grease collection kit for open base (2 tanks, open/close device and drain) | PNC 922639 | <input type="checkbox"/> |
| • Multipurpose hook | PNC 922348 | <input type="checkbox"/> | • Wall support for 10 GN 1/1 oven | PNC 922645 | <input type="checkbox"/> |
| • 4 flanged feet for 6 & 10 GN , 2", 100-130mm | PNC 922351 | <input type="checkbox"/> | • Banquet rack with wheels holding 30 plates for 10 GN 1/1 oven and blast chiller freezer, 65mm pitch | PNC 922648 | <input type="checkbox"/> |
| • Grid for whole duck (8 per grid - 1,8kg each), GN 1/1 | PNC 922362 | <input type="checkbox"/> | • Banquet rack with wheels holding 23 plates for 10 GN 1/1 oven and blast chiller freezer, 85mm pitch | PNC 922649 | <input type="checkbox"/> |
| • Thermal cover for 10 GN 1/1 oven and blast chiller freezer | PNC 922364 | <input type="checkbox"/> | • Dehydration tray, GN 1/1, H=20mm | PNC 922651 | <input type="checkbox"/> |
| | | | • Flat dehydration tray, GN 1/1 | PNC 922652 | <input type="checkbox"/> |
| | | | • Open base for 6 & 10 GN 1/1 oven, disassembled | PNC 922653 | <input type="checkbox"/> |
| | | | • Bakery/pastry rack kit for 10 GN 1/1 oven with 8 racks 400x600mm and 80mm pitch | PNC 922656 | <input type="checkbox"/> |
| | | | • Heat shield for stacked ovens 6 GN 1/1 on 10 GN 1/1 | PNC 922661 | <input type="checkbox"/> |
| | | | • Heat shield for 10 GN 1/1 oven | PNC 922663 | <input type="checkbox"/> |
| | | | • Fixed tray rack for 10 GN 1/1 and 400x600mm grids | PNC 922685 | <input type="checkbox"/> |
| | | | • Kit to fix oven to the wall | PNC 922687 | <input type="checkbox"/> |
| | | | • 4 high adjustable feet for 6 & 10 GN ovens, 100-115MM | PNC 922688 | <input type="checkbox"/> |
| | | | • Tray support for 6 & 10 GN 1/1 open base | PNC 922690 | <input type="checkbox"/> |
| | | | • Reinforced tray rack with wheels, lowest support dedicated to a grease collection tray for 10 GN 1/1 oven, 64mm pitch | PNC 922694 | <input type="checkbox"/> |

- Detergent tank holder for open base PNC 922699
- Bakery/pastry runners 400x600mm for 6 & 10 GN 1/1 oven base PNC 922702
- Wheels for stacked ovens PNC 922704
- Spit for lamb or suckling pig (up to 12kg) for GN 1/1 ovens PNC 922709
- Mesh grilling grid PNC 922713
- Probe holder for liquids PNC 922714
- Odourless hood with fan for 6 & 10 GN 1/1 electric ovens PNC 922718
- Condensation hood with fan for 6 & 10 GN 1/1 electric oven PNC 922723
- Exhaust hood with fan for 6 & 10 GN 1/1 ovens PNC 922728
- Exhaust hood without fan for 6&10 1/1GN ovens PNC 922733
- Fixed tray rack, 8 GN 1/1, 85mm pitch PNC 922741
- Fixed tray rack, 8 GN 2/1, 85mm pitch PNC 922742
- 4 high adjustable feet for 6 & 10 GN ovens, 230-290mm PNC 922745
- Tray for traditional static cooking, H=100mm PNC 922746
- Double-face griddle, one side ribbed and one side smooth, 400x600mm PNC 922747
- TROLLEY FOR GREASE COLLECTION KIT PNC 922752
- Water inlet pressure reducer PNC 922773
- KIT FOR INSTALLATION OF ELECTRIC POWER PEAK MANAGEMENT SYSTEM-6-10 GN OVENS PNC 922774
- Non-stick universal pan, GN 1/1, H=20mm PNC 925000
- Non-stick universal pan, GN 1/ 1, H=40mm PNC 925001
- Non-stick universal pan, GN 1/1, H=60mm PNC 925002
- Double-face griddle, one side ribbed and one side smooth, GN 1/1 PNC 925003
- Aluminum grill, GN 1/1 PNC 925004
- Frying pan for 8 eggs, pancakes, hamburgers, GN 1/1 PNC 925005
- Flat baking tray with 2 edges, GN 1/1 PNC 925006
- Baking tray for 4 baguettes, GN 1/1 PNC 925007
- Potato baker for 28 potatoes, GN 1/1 PNC 925008
- Non-stick universal pan, GN 1/2, H=20mm PNC 925009
- Non-stick universal pan, GN 1/2, H=40mm PNC 925010
- Non-stick universal pan, GN 1/2, H=60mm PNC 925011
- Compatibility kit for installation on previous base GN 1/1 PNC 930217

Front

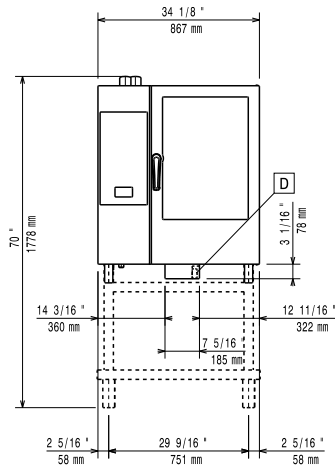

Side

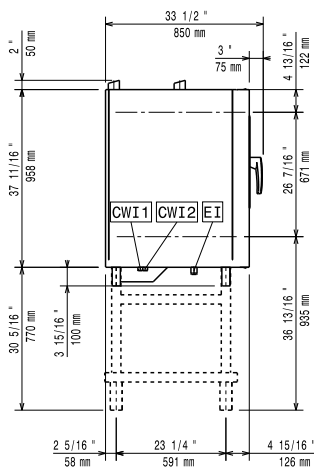

- C-** = Cold Water inlet 1 **EI** = Electrical inlet (power)
- WI-1**
- C-** = Cold Water Inlet 2
- WI-2**
- D** = Drain
- DO** = Overflow drain pipe

Top

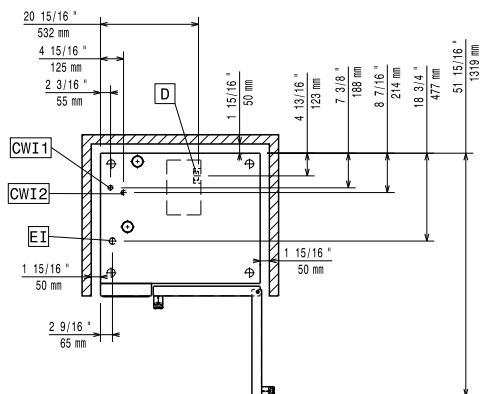

Electric

Supply voltage:

218832 (ZCOE101B2S0) 400-430 V/3N ph/50-60 Hz

Electrical power, default:

19 kW

Electrical power max.:

19.8 kW

Circuit breaker required

Water:

Water inlet "FCW"

connection: 3/4"

Pressure, bar min/max: 1-6 bar

Drain "D": 50mm

Max inlet water supply

temperature: 30 °C

Chlorides: <45 ppm

Conductivity: >50 µS/cm

Electrolux Professional recommends the use of treated water, based on testing of specific water conditions.

Please refer to user manual for detailed water quality information.

Installation:

Clearance:

Clearance: 5 cm rear and right hand sides.

Suggested clearance for service access:

50 cm left hand side.

Capacity:

GN: 10 - 1/1 Gastronorm

Max load capacity: 50 kg

Key Information:

Door hinges:

External dimensions, Width:

867 mm

External dimensions, Depth:

775 mm

External dimensions, Height:

1058 mm

Net weight:

148.5 kg

Shipping weight:

166.5 kg

Shipping volume:

1.06 m³