

Magistar Combi DS Electric Combi Oven 20GN2/1

ITEM # _____

MODEL # _____

NAME # _____

SIS # _____

AIA # _____



218835 (ZCOE202B2S0) Magistar Combi DS combi boiler oven with digital control, 20x2/1GN, electric, programmable, automatic cleaning (Australia)

Short Form Specification

Item No.

Combi oven with high resolution full touch screen interface, multilanguage

- Built-in steam generator with real humidity control based upon Lambda Sensor
- AirFlow air distribution system to achieve maximum performance with 7 fan speed levels
- HP Automatic Cleaning: Automatic and built-in self cleaning system with integrated descale of the steam generator. 5 automatic cycles (soft, medium, strong, extra strong, rinse-only) and economizer functions to save energy, water, detergent and rinse aid
- Cooking modes: Automatic (9 food families with 100+ different pre-installed variants); Programs (a maximum of 1000 recipes can be stored and organized in 16 different categories); Manual (steam, combi and convection cycles); Specialistic Cycles (regeneration, Low Temperature Cooking, proving, EcoDelta, Sous-Vide, Static-Combi, Pasteurization of pasta, dehydration, Food Safe Control and Advanced Food Safe Control)
- Special functions: MultiTimer cooking, Cooking Optimizer to cut running costs, Make-it-Mine to customize interface, SoloMio to customize homepage, agenda Calendar, automatic backup mode to avoid downtime
- USB port to download HACCP data, programs and settings. Connectivity ready
- 6-point multi sensor core temperature probe
- Double-glass door with single LED lights line
- Stainless steel construction throughout
- Supplied with n.1 trolley rack 2/1 GN, 63 mm pitch.

Main Features

- Digital interface with LED backlight buttons with guided selection.
- Built-in steam generator for highly precise humidity and temperature control according to the chosen settings.
- Real humidity control based upon Lambda Sensor to automatically recognize quantity and size of food for consistent quality results.
- Dry, hot convection cycle (25 °C - 300 °C): ideal for low humidity cooking.
- Combination cycle (25 °C - 300 °C): combining convected heat and steam to obtain humidity controlled cooking environment, accelerating the cooking process and reducing weight loss.
- Low temperature Steam cycle (25 °C - 99 °C): ideal for sous-vide, re-thermalization and delicate cooking. Steam cycle (100 °C): seafood and vegetables. High temperature steam (25 °C - 130 °C).
- EcoDelta cooking: cooking with food probe maintaining preset temperature difference between the core of the food and the cooking chamber.
- Pre-set program for Regeneration, ideal for banqueting on plate or rethermalizing on tray.
- Programs mode: a maximum of 100 recipes can be stored in the oven's memory, to recreate the exact same recipe at any time. 4-step cooking programs also available.
- Fan with 5 speed levels from 300 to 1500 RPM and reverse rotation for optimal evenness. Fan stops in less than 5 seconds when door is opened.
- Single sensor core temperature probe included.
- Automatic fast cool down and pre-heat function.
- USB port to download HACCP data, share cooking programs and configurations. USB port also allows to plug-in sous-vide probe (optional accessory).
- Back-up mode with self-diagnosis is automatically activated if a failure occurs to avoid downtime.
- AirFlow air distribution system to achieve maximum performance in chilling/heating evenness and temperature control thanks to a special design of the chamber combined with high precision variable speed fan.
- HP Automatic Cleaning: Automatic and built-in self cleaning system with integrated descale of the steam generator. 5 automatic cycles (soft, medium, strong, extra strong, rinse-only).
- 2 different chemical options available: solid and liquid (requires optional accessory).
- Capacity: 20 GN 2/1 or 40 GN 1/1 trays.
- [NOT TRANSLATED]

Construction

- Double thermo-glazed door with open frame construction, for cool outside door panel. Swing hinged easy-release inner glass on door for easy cleaning.
- Seamless hygienic internal chamber with all rounded corners for easy cleaning.
- 304 AISI stainless steel construction throughout.
- Front access to control board for easy service.

APPROVAL:

- IPX 5 spray water protection certification for easy cleaning.
- Supplied with n.1 trolley rack 2/1 GN, 63 mm pitch.

User Interface & Data Management

- Connectivity ready for real time access to connected appliances from remote and HACCP monitoring (requires optional accessory).
- Connectivity ready for real time access to connected appliances from remote and data monitoring (requires optional accessory – contact the Company for more details).

Sustainability

- Reduced power function for customized slow cooking cycles.

Included Accessories

- 1 of Trolley with tray rack 20 GN 2/1, 63mm pitch (included) PNC 922757

Optional Accessories

- Water softener with cartridge and flow meter (high steam usage) PNC 920003
- Water softener with salt for ovens with automatic regeneration of resin PNC 921305
- Pair of AISI 304 stainless steel grids, GN 1/1 PNC 922017
- Pair of grids for whole chicken (8 per grid - 1,2kg each), GN 1/1 PNC 922036
- AISI 304 stainless steel grid, GN 1/1 PNC 922062
- External side spray unit (needs to be mounted outside and includes support to be mounted on the oven) PNC 922171
- Baking tray for 5 baguettes in perforated aluminum with silicon coating, 400x600x38mm PNC 922189
- Baking tray with 4 edges in perforated aluminum, 400x600x20mm PNC 922190
- Baking tray with 4 edges in aluminum, 400x600x20mm PNC 922191
- Pair of frying baskets PNC 922239
- AISI 304 stainless steel bakery/pastry grid 400x600mm PNC 922264
- Grid for whole chicken (8 per grid - 1,2kg each), GN 1/1 PNC 922266
- Universal skewer rack PNC 922326
- 6 short skewers PNC 922328
- Smoker for lengthwise and crosswise oven (4 kinds of smoker wood chips are available on request) PNC 922338
- Multipurpose hook PNC 922348
- Grease collection tray, GN 2/1, H=60 mm PNC 922357
- Grid for whole duck (8 per grid - 1,8kg each), GN 1/1 PNC 922362
- Thermal cover for 20 GN 2/1 oven and blast chiller freezer PNC 922367
- Wall mounted detergent tank holder PNC 922386
- USB SINGLE POINT PROBE PNC 922390
- External connection kit for detergent and rinse aid PNC 922618
- Dehydration tray, GN 1/1, H=20mm PNC 922651
- Flat dehydration tray, GN 1/1 PNC 922652
- Heat shield for 20 GN 2/1 oven PNC 922658

- Trolley with tray rack, 16 GN 2/1, 84mm pitch PNC 922686
- Kit to fix oven to the wall PNC 922687
- 4 flanged feet for 20 GN , 2", 150mm PNC 922707
- Mesh grilling grid PNC 922713
- Probe holder for liquids PNC 922714
- Tray for traditional static cooking, H=100mm PNC 922746
- Double-face griddle, one side ribbed and one side smooth, 400x600mm PNC 922747
- Trolley with tray rack 20 GN 2/1, 63mm pitch (included) PNC 922757
- Trolley with tray rack, 16 GN 2/1, 80mm pitch PNC 922758
- Banquet trolley with rack holding 92 plates for 20 GN 2/1 oven and blast chiller freezer, 85mm pitch PNC 922760
- Bakery/pastry trolley with rack holding 400x600mm grids for 20 GN 2/1 oven and blast chiller freezer, 80mm pitch (16 runners) PNC 922762
- Banquet trolley with rack holding 116 plates for 20 GN 2/1 oven and blast chiller freezer, 66mm pitch PNC 922764
- Kit compatibility for aos/easyline trolley (produced till 2019) with SkyLine/Magistar 20 GN 2/1 combi oven PNC 922770
- Kit compatibility for aos/easyline 20 GN oven with SkyLine/Magistar trolleys PNC 922771
- Water inlet pressure reducer PNC 922773
- KIT FOR INSTALLATION OF ELECTRIC POWER PEAK MANAGEMENT SYSTEM 20 GN OVENS PNC 922778
- Non-stick universal pan, GN 1/ 1, H=40mm PNC 925001
- Non-stick universal pan, GN 1/1, H=60mm PNC 925002
- Double-face griddle, one side ribbed and one side smooth, GN 1/1 PNC 925003
- Aluminum grill, GN 1/1 PNC 925004
- Frying pan for 8 eggs, pancakes, hamburgers, GN 1/1 PNC 925005
- Flat baking tray with 2 edges, GN 1/1 PNC 925006
- Potato baker for 28 potatoes, GN 1/1 PNC 925008

Front

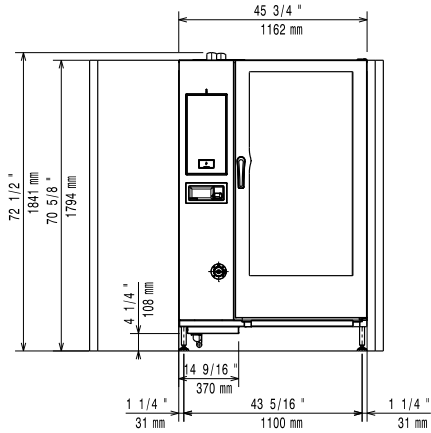

Side

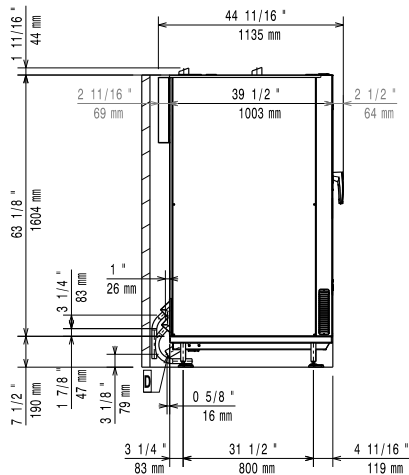

- C-** = Cold Water inlet 1
- WI-1**
- C-** = Cold Water Inlet 2
- WI-2**
- D** = Drain
- DO** = Overflow drain pipe
- EI** = Electrical inlet (power)

Top

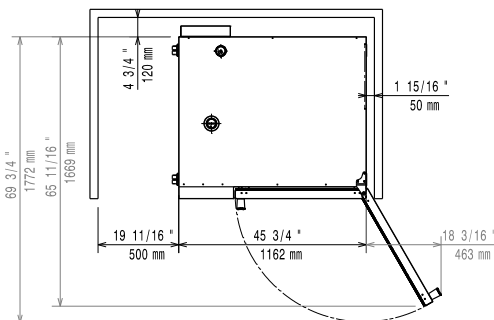

Electric

Supply voltage:

218835 (ZCOE202B2S0) 400-430 V/3N ph/50-60 Hz

Electrical power, default:

65.4 kW

Electrical power max.:

68.3 kW

Circuit breaker required

Water:

Water inlet "FCW"

connection: 3/4"

Pressure, bar min/max: 1-6 bar

Drain "D": 50mm

Max inlet water supply

temperature: 30 °C

Chlorides: <45 ppm

Conductivity: >50 µS/cm

Electrolux Professional recommends the use of treated water, based on testing of specific water conditions.

Please refer to user manual for detailed water quality information.

Installation:

Clearance: 5 cm rear and right hand sides.

Clearance:

Suggested clearance for service access:

50 cm left hand side.

Capacity:

GN:

20 - 2/1 Gastronorm

Max load capacity:

200 kg

Key Information:

Door hinges:

External dimensions, Width:

1162 mm

External dimensions, Depth:

1066 mm

External dimensions, Height:

1794 mm

Net weight:

355.5 kg

Shipping weight:

393.5 kg

Shipping volume:

2.77 m³