

Magistar Combi DI Natural Gas Combi Oven 6GN1/1

ITEM # _____

MODEL # _____

NAME # _____

SIS # _____

AIA # _____

**218970 (ZCOG61C2U0)**

Magistar Combi DI combi boilerless oven with digital control, 6x1/1GN, gas, programmable, automatic cleaning (Australia)

Short Form Specification

Item No. _____

- Combi oven with digital interface with guided selection.
- Boilerless steaming function to add and retain moisture.
 - AirFlow air distribution system to achieve maximum performance with 5 fan speed levels.
 - HP Automatic Cleaning: Automatic and built-in self cleaning system. 5 automatic cycles (soft, medium, strong, extra strong, rinse-only).
 - Cooking modes: Programs (a maximum of 100 recipes can be stored); Manual (steam, combi and convection cycles); EcoDelta cooking cycle.
 - Automatic backup mode to avoid downtime.
 - USB port to download HACCP data, programs and settings. Connectivity ready.
 - Single sensor core temperature probe.
 - Double-glass door with LED lights.
 - Stainless steel construction throughout.
 - Supplied with n.1 tray rack 1/1 GN, 67 mm pitch.

Main Features

- Digital interface with LED backlight buttons with guided selection.
- Boilerless steaming function to add and retain moisture for high quality, consistent cooking results.
- Dry hot convection cycle (max 300 °C) ideal for low humidity cooking. Automatic moistener (11 settings) for boiler-less steam generation.
- EcoDelta cooking: cooking with food probe maintaining preset temperature difference between the core of the food and the cooking chamber.
- Programs mode: a maximum of 100 recipes can be stored in the oven's memory, to recreate the exact same recipe at any time. 4-step cooking programs also available.
- AirFlow air distribution system to achieve maximum performance in chilling/heating evenness and temperature control thanks to a special design of the chamber combined with high precision variable speed fan.
- Fan with 5 speed levels from 300 to 1500 RPM and reverse rotation for optimal evenness. Fan stops in less than 5 seconds when door is opened.
- Single sensor core temperature probe included.
- Automatic fast cool down and pre-heat function.
- HP Automatic Cleaning: Automatic and built-in self cleaning system. 5 automatic cycles (soft, medium, strong, extra strong, rinse-only).
- Grease Collector: predisposed for integrated grease drain and collection for safer operation (dedicated base as optional accessory).
- USB port to download HACCP data, share cooking programs and configurations. USB port also allows to plug-in sous-vide probe (optional accessory).
- Back-up mode with self-diagnosis is automatically activated if a failure occurs to avoid downtime.
- 2 different chemical options available: solid and liquid (requires optional accessory).
- Capacity: 6 GN 1/1 trays.
- [NOT TRANSLATED]

Construction

- Double thermo-glazed door with open frame construction, for cool outside door panel. Swing hinged easy-release inner glass on door for easy cleaning.
- Seamless hygienic internal chamber with all rounded corners for easy cleaning.
- 304 AISI stainless steel construction throughout.
- Front access to control board for easy service.
- IPX 5 spray water protection certification for easy cleaning.
- Supplied with n.1 tray rack 1/1 GN, 67 mm pitch.

User Interface & Data Management

- Connectivity ready for real time access to connected appliances from remote and HACCP monitoring (requires optional accessory).
- Connectivity ready for real time access to connected appliances from remote and data monitoring (requires optional accessory).

APPROVAL: _____

optional accessory – contact the Company for more details).

Optional Accessories

| | | | | | |
|---|------------|--------------------------|--|------------|--------------------------|
| • Water softener with cartridge and flow meter (high steam usage) | PNC 920003 | <input type="checkbox"/> | • Cupboard base with tray support for 6 & 10 GN 1/1 oven | PNC 922614 | <input type="checkbox"/> |
| • Water softener with salt for ovens with automatic regeneration of resin | PNC 921305 | <input type="checkbox"/> | • Hot cupboard base with tray support for 6 & 10 GN 1/1 oven holding GN 1/1 or 400x600mm | PNC 922615 | <input type="checkbox"/> |
| • Wheel kit for 6 & 10 GN 1/1 and 2/1 GN oven base (not for the disassembled one) | PNC 922003 | <input type="checkbox"/> | • External connection kit for detergent and rinse aid | PNC 922618 | <input type="checkbox"/> |
| • Pair of AISI 304 stainless steel grids, GN 1/1 | PNC 922017 | <input type="checkbox"/> | • Grease collection kit for GN 1/1-2/1 cupboard base (trolley with 2 tanks, open/close device and drain) | PNC 922619 | <input type="checkbox"/> |
| • Pair of grids for whole chicken (8 per grid - 1,2kg each), GN 1/1 | PNC 922036 | <input type="checkbox"/> | • Stacking kit for gas 6 GN 1/1 oven placed on gas 6 GN 1/1 oven | PNC 922622 | <input type="checkbox"/> |
| • AISI 304 stainless steel grid, GN 1/1 | PNC 922062 | <input type="checkbox"/> | • Stacking kit for gas 6 GN 1/1 oven placed on gas 10 GN 1/1 oven | PNC 922623 | <input type="checkbox"/> |
| • Grid for whole chicken (4 per grid - 1,2kg each), GN 1/2 | PNC 922086 | <input type="checkbox"/> | • Trolley for slide-in rack for 6 & 10 GN 1/1 oven and blast chiller freezer | PNC 922626 | <input type="checkbox"/> |
| • External side spray unit (needs to be mounted outside and includes support to be mounted on the oven) | PNC 922171 | <input type="checkbox"/> | • Trolley for mobile rack for 2 stacked 6 GN 1/1 ovens on riser | PNC 922628 | <input type="checkbox"/> |
| • Baking tray for 5 baguettes in perforated aluminum with silicon coating, 400x600x38mm | PNC 922189 | <input type="checkbox"/> | • Trolley for mobile rack for 6 GN 1/1 on 6 or 10 GN 1/1 ovens | PNC 922630 | <input type="checkbox"/> |
| • Baking tray with 4 edges in perforated aluminum, 400x600x20mm | PNC 922190 | <input type="checkbox"/> | • Riser on feet for 2 6 GN 1/1 ovens or a 6 GN 1/1 oven on base | PNC 922632 | <input type="checkbox"/> |
| • Baking tray with 4 edges in aluminum, 400x600x20mm | PNC 922191 | <input type="checkbox"/> | • Riser on wheels for stacked 2x6 GN 1/1 ovens, height 250mm | PNC 922635 | <input type="checkbox"/> |
| • Pair of frying baskets | PNC 922239 | <input type="checkbox"/> | • Stainless steel drain kit for 6 & 10 GN oven, dia=50mm | PNC 922636 | <input type="checkbox"/> |
| • AISI 304 stainless steel bakery/pastry grid 400x600mm | PNC 922264 | <input type="checkbox"/> | • Plastic drain kit for 6 & 10 GN oven, dia=50mm | PNC 922637 | <input type="checkbox"/> |
| • Double-step door opening kit | PNC 922265 | <input type="checkbox"/> | • Grease collection kit for open base (2 tanks, open/close device and drain) | PNC 922639 | <input type="checkbox"/> |
| • Grid for whole chicken (8 per grid - 1,2kg each), GN 1/1 | PNC 922266 | <input type="checkbox"/> | • Wall support for 6 GN 1/1 oven | PNC 922643 | <input type="checkbox"/> |
| • Grease collection tray, GN 1/1, H=100 mm | PNC 922321 | <input type="checkbox"/> | • Dehydration tray, GN 1/1, H=20mm | PNC 922651 | <input type="checkbox"/> |
| • Kit universal skewer rack and 4 long skewers for GN 1/1 ovens | PNC 922324 | <input type="checkbox"/> | • Flat dehydration tray, GN 1/1 | PNC 922652 | <input type="checkbox"/> |
| • Universal skewer rack | PNC 922326 | <input type="checkbox"/> | • Open base for 6 & 10 GN 1/1 oven, disassembled | PNC 922653 | <input type="checkbox"/> |
| • 4 long skewers | PNC 922327 | <input type="checkbox"/> | • Bakery/pastry rack kit for 6 GN 1/1 oven with 5 racks 400x600mm and 80mm pitch | PNC 922655 | <input type="checkbox"/> |
| • Smoker for lengthwise and crosswise oven (4 kinds of smoker wood chips are available on request) | PNC 922338 | <input type="checkbox"/> | • Stacking kit for gas 6 GN 1/1 oven placed on 7kg and 15kg crosswise blast chiller freezer | PNC 922657 | <input type="checkbox"/> |
| • Multipurpose hook | PNC 922348 | <input type="checkbox"/> | • Heat shield for stacked ovens 6 GN 1/1 on 6 GN 1/1 | PNC 922660 | <input type="checkbox"/> |
| • 4 flanged feet for 6 & 10 GN , 2", 100-130mm | PNC 922351 | <input type="checkbox"/> | • Heat shield for stacked ovens 6 GN 1/1 on 10 GN 1/1 | PNC 922661 | <input type="checkbox"/> |
| • Grid for whole duck (8 per grid - 1,8kg each), GN 1/1 | PNC 922362 | <input type="checkbox"/> | • Heat shield for 6 GN 1/1 oven | PNC 922662 | <input type="checkbox"/> |
| • Tray support for 6 & 10 GN 1/1 disassembled open base | PNC 922382 | <input type="checkbox"/> | • Kit to convert from natural gas to LPG | PNC 922670 | <input type="checkbox"/> |
| • Wall mounted detergent tank holder | PNC 922386 | <input type="checkbox"/> | • Kit to convert from LPG to natural gas | PNC 922671 | <input type="checkbox"/> |
| • USB SINGLE POINT PROBE | PNC 922390 | <input type="checkbox"/> | • Flue condenser for gas oven | PNC 922678 | <input type="checkbox"/> |
| • Tray rack with wheels, 6 GN 1/1, 65mm pitch (included) | PNC 922600 | <input type="checkbox"/> | • Fixed tray rack for 6 GN 1/1 and 400x600mm grids | PNC 922684 | <input type="checkbox"/> |
| • Tray rack with wheels, 5 GN 1/1, 80mm pitch | PNC 922606 | <input type="checkbox"/> | • Kit to fix oven to the wall | PNC 922687 | <input type="checkbox"/> |
| • Bakery/pastry tray rack with wheels holding 400x600mm grids for 6 GN 1/1 oven and blast chiller freezer, 80mm pitch (5 runners) | PNC 922607 | <input type="checkbox"/> | • 4 high adjustable feet for 6 & 10 GN ovens, 100-115MM | PNC 922688 | <input type="checkbox"/> |
| • Slide-in rack with handle for 6 & 10 GN 1/1 oven | PNC 922610 | <input type="checkbox"/> | • Tray support for 6 & 10 GN 1/1 open base | PNC 922690 | <input type="checkbox"/> |
| • Open base with tray support for 6 & 10 GN 1/1 oven | PNC 922612 | <input type="checkbox"/> | • Detergent tank holder for open base | PNC 922699 | <input type="checkbox"/> |
| | | | • Bakery/pastry runners 400x600mm for 6 & 10 GN 1/1 oven base | PNC 922702 | <input type="checkbox"/> |
| | | | • Wheels for stacked ovens | PNC 922704 | <input type="checkbox"/> |
| | | | • CHIMNEY ADAPTOR NEEDED IN CASE OF CONVERSION OF 6 GN 1/1 OR 6 GN 2/1 OVENS FROM NATURAL GAS TO LPG | PNC 922706 | <input type="checkbox"/> |

- Mesh grilling grid PNC 922713
- Probe holder for liquids PNC 922714
- Exhaust hood with fan for 6 & 10 GN 1/1 ovens PNC 922728
- Exhaust hood without fan for 6&10 1/1GN ovens PNC 922733
- Fixed tray rack, 5 GN 1/1, 85mm pitch PNC 922740
- 4 high adjustable feet for 6 & 10 GN ovens, 230-290mm PNC 922745
- Tray for traditional static cooking, H=100mm PNC 922746
- Double-face griddle, one side ribbed and one side smooth, 400x600mm PNC 922747
- TROLLEY FOR GREASE COLLECTION KIT PNC 922752
- Water inlet pressure reducer PNC 922773
- EXTENSION FOR CONDENSATION TUBE PNC 922776
- Non-stick universal pan, GN 1/1, H=20mm PNC 925000
- Non-stick universal pan, GN 1/ 1, H=40mm PNC 925001
- Non-stick universal pan, GN 1/1, H=60mm PNC 925002
- Double-face griddle, one side ribbed and one side smooth, GN 1/1 PNC 925003
- Aluminum grill, GN 1/1 PNC 925004
- Frying pan for 8 eggs, pancakes, hamburgers, GN 1/1 PNC 925005
- Flat baking tray with 2 edges, GN 1/1 PNC 925006
- Baking tray for 4 baguettes, GN 1/1 PNC 925007
- Potato baker for 28 potatoes, GN 1/1 PNC 925008
- Non-stick universal pan, GN 1/2, H=20mm PNC 925009
- Non-stick universal pan, GN 1/2, H=40mm PNC 925010
- Non-stick universal pan, GN 1/2, H=60mm PNC 925011
- Compatibility kit for installation on previous base GN 1/1 PNC 930217

Front

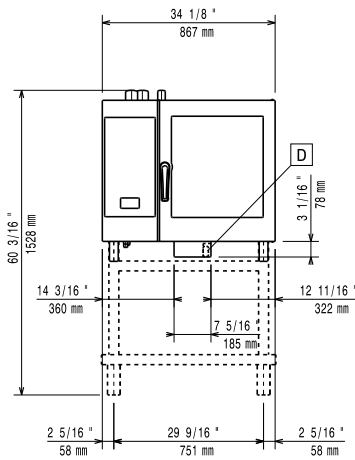

Side

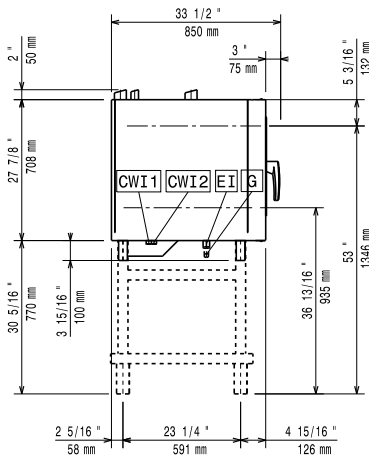

- C-WI-1** = Cold Water inlet 1 **EI** = Electrical inlet (power)
- C-WI-2** = Cold Water Inlet 2 **G** = Gas connection
- D** = Drain
- DO** = Overflow drain pipe

Top

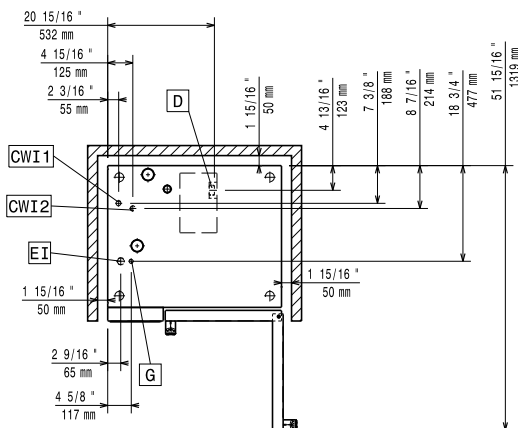

Electric

Supply voltage:
218970 (ZCOG61C2U0) 230-240 V/1 ph/50 Hz
Electrical power, default: 1.1 kW
Electrical power max.: 1.1 kW
Circuit breaker required

Gas

Gas Power: 13 kW
Standard gas delivery: Natural Gas G20
ISO 7/1 gas connection diameter: 1/2" MNPT
Total thermal load: 44317 BTU (13 kW)

Water:

Water inlet "FCW" connection: 3/4"
Pressure, bar min/max: 1-6 bar
Drain "D": 50mm
Max inlet water supply temperature: 30 °C
Chlorides: <10 ppm
Conductivity: >50 µS/cm
Electrolux Professional recommends the use of treated water, based on testing of specific water conditions.
Please refer to user manual for detailed water quality information.

Installation:

Clearance: Clearance: 5 cm rear and right hand sides.
Suggested clearance for service access: 50 cm left hand side.

Capacity:

GN: 6 - 1/1 Gastronorm
Max load capacity: 30 kg

Key Information:

Door hinges:
External dimensions, Width: 867 mm
External dimensions, Depth: 775 mm
External dimensions, Height: 808 mm
Net weight: 122.5 kg
Shipping weight: 139.5 kg
Shipping volume: 0.84 m³