

Modular Cooking Range Line EVO900 One Well Electric Fryer 23 liter with Electronic control

ITEM # _____

MODEL # _____

NAME # _____

SIS # _____

AIA # _____

**392339 (Z9KKHDBAMCG)**

23-lt electric fryer with 1 "V" shaped well (external heating elements) and 2 half size baskets, time and temperature electronic control - hp - free standing

Short Form Specification

Item No. _____

High efficiency external infrared heating elements (18kW) with innovative deflectors attached to the outside of the well. Deep drawn V-Shaped well and equipped with electronic control panel. Melting function to safely heat-up solid shortening used to fry products. Oil drains through a tap into a container positioned under the well. Height adjustable feet in stainless steel. Exterior panels in stainless steel. Worktop in 20/10, stainless steel. Right-angled side edges eliminate gaps and possible dirt traps between units.

Main Features

- Deep drawn V-Shaped well.
- Interior of well with rounded corners for ease of cleaning.
- External infrared heating elements for ease of cleaning of internal well.
- Melting function to safely heat-up solid shortening used to fry products.
- Thermostatic regulation of oil temperature up to a maximum of 185 °C.
- Overheat protection thermostat as standard on all units.
- Oil drains through a tap into a drainage container positioned under the well.
- All major compartments located in front of unit for ease of maintenance.
- Unit to be equipped with electronic control panel.
- Unit is 93 cm deep to give a larger working surface area.
- IPX5 water resistance certification.
- The special design of the control knob system guarantees against water infiltration.
- Exterior panels in Stainless Steel with Scotch Brite finish.
- Model has right-angled side edges to allow flush fitting joints between units, eliminating gaps and possible dirt traps.
- Unit delivered with four 50 mm legs in stainless steel as standard (all round Stainless steel kick plates as option).
- Supplied as standard with 2 half size baskets and 1 right side door for cupboard.

Construction

- All exterior panels in Stainless Steel with Scotch Brite finishing.
- Model has right-angled side edges to allow flush fitting joints between units, eliminating gaps and possible dirt traps.
- Interior of well with rounded corners for ease of cleaning.
- Unit is 900mm deep to give a larger working surface area.
- Unit delivered with four 50 mm legs in stainless steel as standard.
- IPX5 water resistance certification.

Sustainability

- [NOT TRANSLATED]

APPROVAL: _____



Modular Cooking Range Line EVO900 One Well Electric Fryer 23 liter with Electronic control

Included Accessories

- 1 of OIL FILTER S/S FOR 23 LT FRYERS PNC 200086
- 1 of DOOR FOR OPEN BASE CUPBOARD PNC 206350
- 1 of 2 half size baskets for 18/23lt well fryers PNC 927223

Optional Accessories

- OIL FILTER S/S FOR 23 LT FRYERS PNC 200086
- Junction sealing kit PNC 206086
- 4 wheels, 2 swivelling with brake (EVO700/900). It is mandatory to install with base supports for feet/wheels. PNC 206135
- Flanged feet kit PNC 206136
- Pair of side kicking strips PNC 206180
- Hygienic lid for 23lt fryers PNC 206201
- Frontal kicking strip for 23lt fryers in two parts PNC 206203
- Extension pipe for oil drainage for 15lt, 18lt, 23lt fryers PNC 206209
- Base support for wheels (lateral) for 23lt fryers and pastacookers and refrigerated bases (900) PNC 206372
- SEDIMENT TRAY FOR 23LT FRYER PNC 921023
- 2 half size baskets for 18/23lt well fryers PNC 927223
- 1 full size basket for 18/23lt well fryers PNC 927226
- Unclogging rod for 23lt fryers drainage pipe PNC 927227
- Deflector for floured products for the 23lt fryer PNC 960645



Modular Cooking Range Line
EVO900 One Well Electric Fryer 23 liter with Electronic control

The company reserves the right to make modifications to the products without prior notice. All information correct at time of printing.

Modular Cooking Range Line EVO900 One Well Electric Fryer 23 liter with Electronic control

Front

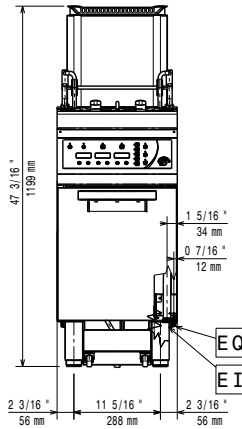

Side

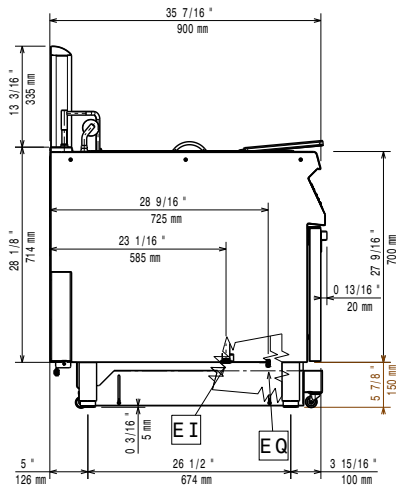

EI = Electrical inlet (power)
EQ = Equipotential screw

Top

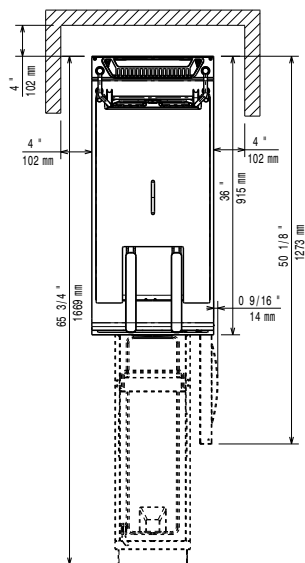

Electric

Supply voltage:

392339 (Z9KKHDBAMCG)

380-400 V/3N ph/50/60 Hz

Total Watts:

18 kW

Key Information:

Usable well dimensions (width):	340 mm
Usable well dimensions (height):	575 mm
Usable well dimensions (depth):	400 mm
Well capacity:	21 lt MIN; 23 lt MAX
Performance*:	37.6 kg\hr
Thermostat Range:	110 °C MIN; 190 °C MAX
Net weight:	86 kg
Shipping weight:	87 kg
Shipping height:	1480 mm
Shipping width:	460 mm
Shipping depth:	1020 mm
Shipping volume:	0.69 m ³

If appliance is set up or next to or against temperature sensitive furniture or similar, a safety gap of approximately 150 mm should be maintained or some form of heat insulation fitted.

*Based on: ASTM F1361-Deep fat fryers
[NOT TRANSLATED] EFE91E23