

Magistar Combi TS Natural Gas Combi Oven 6GN1/1, boiler AISI 316L

ITEM # _____

MODEL # _____

NAME # _____

SIS # _____

AIA # _____



218795 (ZCOG61T3G31)

Magistar Combi TS combi boiler oven with touch screen control, 6x1/1GN, gas, 3 cooking modes (automatic, recipe program, manual), automatic cleaning, boiler in AISI 316L, 3-glass door

Short Form Specification

Item No.

Combi oven with high resolution full touch screen interface, multilanguage

- Built-in steam generator (in s/s 316L) with real humidity control based upon Lambda Sensor
- AirFlow air distribution system to achieve maximum performance with 7 fan speed levels
- HP Automatic Cleaning: Automatic and built-in self cleaning system with integrated descale of the steam generator. 4 automatic cycles (short, medium, intensive, rinse) and economizer functions to save energy, water, detergent and rinse aid
- Cooking modes: Automatic (9 food families with 100+ different pre-installed variants); Programs (a maximum of 1000 recipes can be stored and organized in 16 different categories); Manual (steam, combi and convection cycles); Specialistic Cycles (regeneration, Low Temperature Cooking, proving, EcoDelta, Sous-Vide, Static-Combi, Pasteurization of pasta, dehydration, Food Safe Control and Advanced Food Safe Control)
- Special functions: MultiTimer cooking, Cooking Optimizer to cut running costs, Make-it-Mine to customize interface, Match connection to Rapido Chiller, SoloMio to customize homepage, agenda Calendar, automatic backup mode to avoid downtime
- USB port to download HACCP data, programs and settings.
- Connectivity for real time access, remote software update, HACCP, recipe and energy management (optional).
- 6-point multi sensor core temperature probe
- Triple-glass door with double LED lights line.
- Stainless steel construction throughout
- Supplied with n.1 tray rack 1/1 GN, 67 mm pitch.

Main Features

- Zanussi Professional recommends the use of treated water to guarantee optimal cooking results and extend the life of the appliance. Check local water condition to select the appropriate water filter. More info available on the website.
- 6-point multi sensor core temperature probe for maximum precision and food safety.
- Programs mode: a maximum of 1000 recipes can be stored in the oven's memory, to recreate the exact same recipe at any time. The recipes can be grouped in 16 different categories to better organize the menu. 16-step cooking programs also available.
- Dry, hot convection cycle (25 °C - 300 °C): ideal for low humidity cooking.
- Combination cycle (25 °C - 300 °C): combining convected heat and steam to obtain humidity controlled cooking environment, accelerating the cooking process and reducing weight loss.
- Low temperature Steam cycle (25 °C - 99 °C): ideal for sous-vide, re-thermalization and delicate cooking.
Steam cycle (100 °C): seafood and vegetables.
High temperature steam (101 °C - 130 °C).
- Built-in steam generator for highly precise humidity and temperature control according to the chosen settings.
- Real humidity control based upon Lambda Sensor to automatically recognize quantity and size of food for consistent quality results.
- Fan with 7 speed levels from 300 to 1500 RPM and reverse rotation for optimal evenness. Fan stops in less than 5 seconds when door is opened.
- Automatic fast cool down and pre-heat function.
- Automatic mode including 9 food families (meat, poultry, fish, vegetables, pasta/rice, eggs, savory and sweet bakery, bread, dessert) with 100+ different pre-installed variants. Through Automatic Sensing Phase the oven optimizes the cooking process according to size, quantity and type of food loaded to achieve the selected cooking result. Real time overview of the cooking parameters. Possibility to personalize and save up to 70 variants per family.
- Cycles :
 - Regeneration (ideal for banqueting on plate or rethermalizing on tray),
 - Low Temperature Cooking (to minimize weight loss and maximize food quality) Patented US7750272B2 and related family,
 - Proving cycle,
 - EcoDelta cooking, cooking with food probe maintaining preset temperature difference between the core of the food and the cooking chamber,
 - Sous-vide cooking,
 - Static Combi (to reproduce traditional cooking from static oven),
 - Pasteurization of pasta,
 - Dehydration cycle (ideal for drying fruits, vegetables, meats, seafood),
 - Food Safe Control (to automatically monitor safety of cooking process in compliance with HACCP hygienic standards) Patented US6818865B2 and related family,
 - Advanced Food Safe Control (to drive the cooking with pasteurization factor).
- Back-up mode with self-diagnosis is automatically activated if a failure occurs to avoid downtime.
- OptiFlow air distribution system to achieve maximum performance in chilling/heating evenness and temperature

APPROVAL: _____

control thanks to a special design of the chamber.

- Short cleaning cycle: optimized cleaning cycle with a duration of just 33 minutes, improving efficiency and reducing downtime.
- 6-point multi sensor core temperature probe for maximum precision and food safety (optional accessory).
- AirFlow air distribution system to achieve maximum performance in chilling/heating evenness and temperature control thanks to a special design of the chamber combined with high precision variable speed fan.
- Grease Collector: predisposed for integrated grease drain and collection for safer operation (dedicated base as optional accessory).
- MultiTimer function to manage up to 60 different cooking cycles at the same time, improving flexibility and ensuring excellent cooking results. Can be saved up to 200 MultiTimer programs.
- HP Automatic Cleaning: automatic and built-in self cleaning system with 4 automatic cycles (short, medium, intensive, rinse) and integrated descale of the steam generator.

Construction

- Boiler in 316L AISI to protect against corrosion.
- Integrated spray gun with automatic retracting system for fast rinsing.
- 304 AISI stainless steel construction throughout.
- IPX5 spray water protection certification for easy cleaning.
- Hygienic internal chamber with all rounded corners for easy cleaning.
- Triple thermo-glazed door with 2 hinged inside panels for easy cleaning and double LED lights line.
- Front access to control board for easy service.

User Interface & Data Management

- Make-it-mine feature to allow full personalization or locking of the user interface.
- Pictures upload for full customization of cooking cycles.
- Trainings and guidances supporting materials easily accessible by scanning QR-Code with any mobile device.
- USB port to download HACCP data, share cooking programs and configurations. USB port also allows to plug-in sous-vide probe (optional accessory).
- High resolution full touch screen interface (translated in more than 30 languages) - color-blind friendly panel.
- Automatic consumption visualization at the end of the cycle.
- Connectivity for remote real time access, easy HACCP management, equipment uptime increase, consumption tracking and energy management (requires optional accessory).
- Calendar works as an agenda where the user can plan the daily work and receive personalized alerts for each task.
- SoloMio lets the user group the favorite functions in the homepage for immediate access.

Sustainability

- Energy Star 2.0 certified product.
- Reduced power function for customized slow cooking cycles.
- Zero Waste provides chefs with useful tips for minimizing food waste. Zero Waste is a library of Automatic recipes that aims to: - give a second life to raw food close to expiration date (e.g., from milk to yogurt) - obtain genuine and tasty dishes from overripe fruit/vegetables (usually considered not appropriate for sale) - promote the use of typically discarded food items (e.g., carrot peels).
- C22 and C25 detergents are formulated without phosphates and phosphorus (C25 is also maleic acid-free), making them safe for both the environment and human health.
- The outer cardboard packaging is made from 70% recycled

materials and FSC*-certified paper, printed with eco-friendly, water-based ink to support sustainability and environmental responsibility.

<i>(*Forest Stewardship Council is the world's leading organization for sustainable forest management).</i>

- Triple-glass door minimize your energy loss.*

*<i>Approx. -10% of idle energy consumption in convection based on test in compliance with ASTM Standard F2861-20</i>

- <p>Cooking Optimizer function organizes the cooking sequence of the chosen cycles optimizing the work in the kitchen from a time and energy efficiency point of view.</p>
- Cooking Optimizer function organizes the cooking sequence of the chosen cycles optimizing the work in the kitchen from a time and energy efficiency point of view.
- Save energy, water, detergent and rinse aid with green functions.
- Automatic and built-in self cleaning system with 4 automatic cycles (short, medium, intensive, rinse) and integrated descale of the steam generator.

Optional Accessories

• External reverse osmosis filter for single tank Dishwashers with atmosphere boiler and Ovens	PNC 864388	<input type="checkbox"/>
• Water filter with cartridge and flow meter for low steam usage (less than 2 hours of full steam per day)	PNC 920004	<input type="checkbox"/>
• Water filter with cartridge and flow meter for medium steam usage	PNC 920005	<input type="checkbox"/>
• Wheel kit for 6 & 10 GN 1/1 and 2/1 GN oven base (not for the disassembled one)	PNC 922003	<input type="checkbox"/>
• Pair of AISI 304 stainless steel grids, GN 1/1	PNC 922017	<input type="checkbox"/>
• Pair of grids for whole chicken (8 per grid - 1,2kg each), GN 1/1	PNC 922036	<input type="checkbox"/>
• AISI 304 stainless steel grid, GN 1/1	PNC 922062	<input type="checkbox"/>
• Grid for whole chicken (4 per grid - 1,2kg each), GN 1/2	PNC 922086	<input type="checkbox"/>
• External side spray unit (needs to be mounted outside and includes support to be mounted on the oven)	PNC 922171	<input type="checkbox"/>
• Baking tray for 5 baguettes in perforated aluminum with silicon coating, 400x600x38mm	PNC 922189	<input type="checkbox"/>
• Baking tray with 4 edges in perforated aluminum, 400x600x20mm	PNC 922190	<input type="checkbox"/>
• Baking tray with 4 edges in aluminum, 400x600x20mm	PNC 922191	<input type="checkbox"/>
• Pair of frying baskets	PNC 922239	<input type="checkbox"/>
• AISI 304 stainless steel bakery/pastry grid 400x600mm	PNC 922264	<input type="checkbox"/>
• Double-step door opening kit	PNC 922265	<input type="checkbox"/>
• Grid for whole chicken (8 per grid - 1,2kg each), GN 1/1	PNC 922266	<input type="checkbox"/>
• USB probe for sous-vide cooking	PNC 922281	<input type="checkbox"/>
• Grease collection tray, GN 1/1, H=100 mm	PNC 922321	<input type="checkbox"/>
• Kit universal skewer rack and 4 long skewers for GN 1/1 ovens	PNC 922324	<input type="checkbox"/>
• Universal skewer rack	PNC 922326	<input type="checkbox"/>
• 4 long skewers	PNC 922327	<input type="checkbox"/>
• Grease collection tray, GN 1/1, H=40 mm	PNC 922329	<input type="checkbox"/>
• Smoker for lengthwise and crosswise oven	PNC 922338	<input type="checkbox"/>
• Multipurpose hook	PNC 922348	<input type="checkbox"/>
• 4 flanged feet for 6 & 10 GN , 2", 100-130mm	PNC 922351	<input type="checkbox"/>

Magistar Combi TS
Natural Gas Combi Oven 6GN1/1, boiler AISI 316L

The company reserves the right to make modifications to the products without prior notice. All information correct at time of printing.

• Grid for whole duck (8 per grid - 1,8kg each), GN 1/1	PNC 922362	<input type="checkbox"/>	• Open base for 6 & 10 GN 1/1 oven, disassembled - NO accessory can be fitted with the exception of 922382	PNC 922653	<input type="checkbox"/>
• Tray support for 6 & 10 GN 1/1 disassembled open base	PNC 922382	<input type="checkbox"/>	• Bakery/pastry rack kit for 6 GN 1/1 oven with 5 racks 400x600mm and 80mm pitch	PNC 922655	<input type="checkbox"/>
• Wall mounted detergent tank holder	PNC 922386	<input type="checkbox"/>	• Stacking kit for 6 GN 1/1 combi or convection oven on 15&25kg blast chiller/freezer crosswise	PNC 922657	<input type="checkbox"/>
• USB single point probe	PNC 922390	<input type="checkbox"/>	• Heat shield for stacked ovens 6 GN 1/1 on 6 GN 1/1	PNC 922660	<input type="checkbox"/>
• IoT module for OnE Connected (combi ovens, blast chiller/freezers, rack type DW) and Match (one IoT board per appliance - to connect oven to the blast chiller for Cook&Chill process).	PNC 922421	<input type="checkbox"/>	• Heat shield for stacked ovens 6 GN 1/1 on 10 GN 1/1	PNC 922661	<input type="checkbox"/>
• Connectivity router (WiFi and LAN)	PNC 922435	<input type="checkbox"/>	• Heat shield for 6 GN 1/1 oven	PNC 922662	<input type="checkbox"/>
• Riser on feet (h=250mm) for 2x6 GN 1/1 ovens or a 6 GN 1/1 oven on base	PNC 922436	<input type="checkbox"/>	• Kit to convert from natural gas to LPG	PNC 922670	<input type="checkbox"/>
• Steam optimizer	PNC 922440	<input type="checkbox"/>	• Kit to convert from LPG to natural gas	PNC 922671	<input type="checkbox"/>
• Grease collection kit for GN 1/1-2/1 open base (2 tanks, open/close device for drain)	PNC 922451	<input type="checkbox"/>	• Flue condenser for gas oven	PNC 922678	<input type="checkbox"/>
• Grease collection kit for ovens GN 1/1 & 2/1 (2 plastic tanks, connection valve with pipe for drain)	PNC 922452	<input type="checkbox"/>	• Fixed tray rack for 6 GN 1/1 and 400x600mm grids	PNC 922684	<input type="checkbox"/>
• Grease collection kit for stacked ovens 6 GN on 6 GN 1/1 - 2/1, with riser	PNC 922453	<input type="checkbox"/>	• Kit to fix oven to the wall	PNC 922687	<input type="checkbox"/>
• Tray rack with wheels, 6 GN 1/1, 65mm pitch	PNC 922600	<input type="checkbox"/>	• 4 high adjustable feet for 6 & 10 GN ovens, 100-115MM	PNC 922688	<input type="checkbox"/>
• Tray rack with wheels 5 GN 1/1, 80mm pitch	PNC 922606	<input type="checkbox"/>	• Tray support for 6 & 10 GN 1/1 oven base	PNC 922690	<input type="checkbox"/>
• Bakery/pastry tray rack with wheels holding 400x600mm grids for 6 GN 1/1 oven and blast chiller freezer, 80mm pitch (5 runners)	PNC 922607	<input type="checkbox"/>	• Detergent tank holder for open base	PNC 922699	<input type="checkbox"/>
• Slide-in rack with handle for 6 & 10 GN 1/1 oven	PNC 922610	<input type="checkbox"/>	• Bakery/pastry runners 400x600mm for 6 & 10 GN 1/1 oven base	PNC 922702	<input type="checkbox"/>
• Open base with tray support for 6 & 10 GN 1/1 oven	PNC 922612	<input type="checkbox"/>	• Wheels for stacked ovens	PNC 922704	<input type="checkbox"/>
• Cupboard base with tray support for 6 & 10 GN 1/1 oven	PNC 922614	<input type="checkbox"/>	• Chimney adaptor needed in case of conversion of 6 GN 1/1 or 6 GN 2/1 ovens from natural gas to LPG	PNC 922706	<input type="checkbox"/>
• Hot cupboard base with tray support for 6 & 10 GN 1/1 oven holding GN 1/1 or 400x600mm	PNC 922615	<input type="checkbox"/>	• Mesh grilling grid, GN 1/1	PNC 922713	<input type="checkbox"/>
• External connection kit for liquid detergent and rinse aid	PNC 922618	<input type="checkbox"/>	• Probe holder for liquids	PNC 922714	<input type="checkbox"/>
• Stacking kit for 6 GN 1/1 oven placed on gas 6 GN 1/1 oven	PNC 922622	<input type="checkbox"/>	• Exhaust hood with fan for 6 & 10 GN 1/1 ovens	PNC 922728	<input type="checkbox"/>
• Stacking kit for 6 GN 1/1 oven placed on gas 10 GN 1/1 oven	PNC 922623	<input type="checkbox"/>	• Exhaust hood with fan for stacking 6+6 or 6+10 GN 1/1 ovens	PNC 922732	<input type="checkbox"/>
• Trolley for slide-in rack for 6 & 10 GN 1/1 oven and blast chiller freezer	PNC 922626	<input type="checkbox"/>	• Exhaust hood without fan for 6&10 1/1GN ovens	PNC 922733	<input type="checkbox"/>
• Trolley for mobile rack for 6 GN 1/1 on 6 or 10 GN 1/1 ovens	PNC 922630	<input type="checkbox"/>	• Exhaust hood without fan for stacking 6+6 or 6+10 GN 1/1 ovens	PNC 922737	<input type="checkbox"/>
• Riser on feet for 2 6 GN 1/1 ovens or a 6 GN 1/1 oven on base	PNC 922632	<input type="checkbox"/>	• 4 high adjustable feet for 6 & 10 GN ovens, 230-290mm	PNC 922745	<input type="checkbox"/>
• Riser on wheels for stacked 2x6 GN 1/1 ovens, height 250mm	PNC 922635	<input type="checkbox"/>	• Tray for traditional static cooking, H=100mm	PNC 922746	<input type="checkbox"/>
• Stainless steel drain kit for 6 & 10 GN oven, dia=50mm	PNC 922636	<input type="checkbox"/>	• Double-face griddle, one side ribbed and one side smooth, 400x600mm	PNC 922747	<input type="checkbox"/>
• Plastic drain kit for 6 & 10 GN oven, dia=50mm	PNC 922637	<input type="checkbox"/>	• Hood Hopper to directly connect the Hood to the centralized ventilation system, for Standard Hoods (with fan motor) and Hoods without fan motor	PNC 922751	<input type="checkbox"/>
• Wall support for 6 GN 1/1 oven	PNC 922643	<input type="checkbox"/>	• Trolley for grease collection kit	PNC 922752	<input type="checkbox"/>
• Dehydration tray, GN 1/1, H=20mm	PNC 922651	<input type="checkbox"/>	• Water inlet pressure reducer	PNC 922773	<input type="checkbox"/>
• Flat dehydration tray, GN 1/1	PNC 922652	<input type="checkbox"/>	• Extension for condensation tube, 37cm	PNC 922776	<input type="checkbox"/>
			• Non-stick universal pan, GN 1/1, H=20mm	PNC 925000	<input type="checkbox"/>
			• Non-stick universal pan, GN 1/1, H=40mm	PNC 925001	<input type="checkbox"/>
			• Non-stick universal pan, GN 1/1, H=60mm	PNC 925002	<input type="checkbox"/>
			• Double-face griddle, one side ribbed and one side smooth, GN 1/1	PNC 925003	<input type="checkbox"/>
			• Aluminum grill, GN 1/1	PNC 925004	<input type="checkbox"/>
			• Frying pan for 8 eggs, pancakes, hamburgers, GN 1/1	PNC 925005	<input type="checkbox"/>
			• Flat baking tray with 2 edges, GN 1/1	PNC 925006	<input type="checkbox"/>

- Baking tray for 4 baguettes, GN 1/1 PNC 925007
- Potato baker for 28 potatoes, GN 1/1 PNC 925008
- Non-stick universal pan, GN 1/2, H=20mm PNC 925009
- Non-stick universal pan, GN 1/2, H=40mm PNC 925010
- Non-stick universal pan, GN 1/2, H=60mm PNC 925011
- Kit of 6 non-stick universal pans, GN 1/1, H=20mm PNC 925012
- Kit of 6 non-stick universal pans, GN 1/1, H=40mm PNC 925013
- Kit of 6 non-stick universal pan GN 1/1, H=60mm PNC 925014

Front

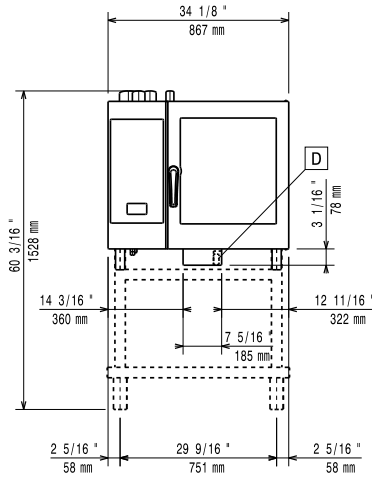

Side

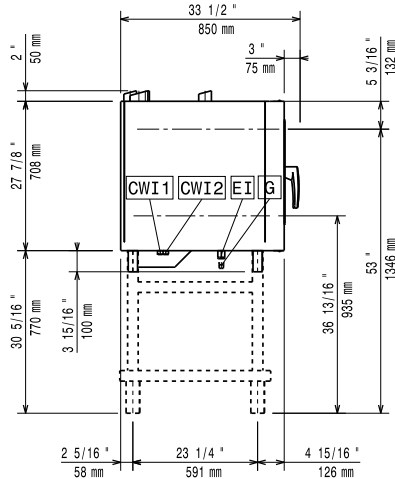

- CWI1** = Cold Water inlet 1 (cleaning) **EI** = Electrical inlet (power)
CWI2 = Cold Water Inlet 2 (steam generator) **G** = Gas connection
D = Drain
DO = Overflow drain pipe

Top

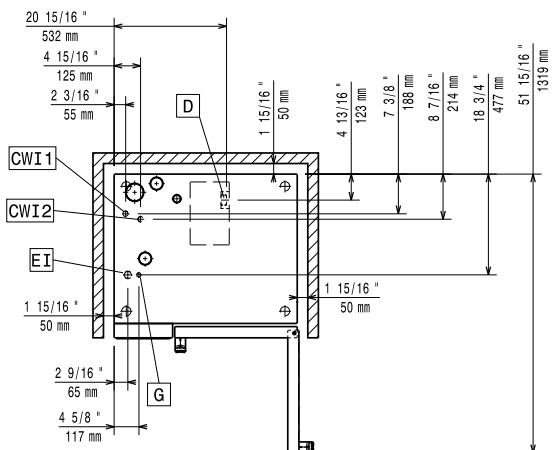

Electric

Supply voltage:	220-240 V/1 ph/50 Hz
Electrical power, max:	1.1 kW
Electrical power, default:	1.1 kW

Gas

Total thermal load:	76429 BTU (19 kW)
Gas Power:	19 kW
Standard gas delivery:	Natural Gas G20
ISO 7/1 gas connection diameter:	1/2" MNPT

Water:

Inlet water temperature, max:	30 °C
Inlet water pipe size (CWI1, CWI2):	3/4"
Pressure, min-max:	1-6 bar
Chlorides:	<20 ppm
Conductivity:	>50 µS/cm
Drain "D":	50mm

Capacity:

Trays type:	6 (GN 1/1)
Max load capacity:	30 kg

Key Information:

Door hinges:	Right Side
External dimensions, Width:	867 mm
External dimensions, Depth:	775 mm
External dimensions, Height:	808 mm
Weight:	152 kg
Net weight:	135 kg
Shipping weight:	152 kg
Shipping volume:	0.89 m ³

ISO Certificates

ISO Standards:	ISO 9001; ISO 14001; ISO 45001; ISO 50001
----------------	---