

Warewashing Warewashing Undercounter for 600x400mm trays, double skin, atm boiler, 30baskets/h

ITEM # _____

MODEL # _____

NAME # _____

SIS # _____

AIA # _____



402315 (ZXLIG)

Undercounter Dishwasher for 600x400mm trays with double skin, atmospheric boiler, drain pump and detergent and rinse aid dispenser, 360 trays/h

Short Form Specification

Item No.

Unit shall be Undercounter dishwasher type hot water rinsing using rack dimension of 600*400mm. Electrical characteristics to be 400 volts three phase 50Hz operation, convertible to single phase on-site. Washing performance is ensure by a powerful wash pump, large capacity wash tank, upper and lower revolving spray arms. Soft start wash pump to avoid accidental breakage of crystal wares. Rinse temperature and pressure guaranteed by built in pressure boiler. Uses 2.5 liters of clean water per final rinse. Three automatic cycles for different types of wares. Double skin insulated, counter-balance door. Double skin cabinet. Pressed wash tank with round corners. 304 AISI stainless steel construction to include door, external panels, frame, wash tank, tank filters, wash arms and rinse arms. The unit shall include rinse aid dispenser pump and is equipped with electric cable.

Main Features

- Washing system endowed with rotating washing arms, high powered wash pump and large capacity boiler for professional washing.
- Simple service from the front.
- Built-in rinse aid and detergent dispenser with automatic initial and continuous cycle loading for perfect result while minimizing service and maintenance needs.
- Double skinned insulated wall ensures a low noise level and a reduction in heat loss from the machine.
- Low noise level.
- Three phase or single phase electrical connection, convertible on-site.
- Easy to remove wash/rinse arms for cleaning.
- Built-in atmospheric boiler with rinse booster pump to provide constant water temperature and pressure for rinsing, independent from water inlet.
- A pause of a few seconds after washing and before rinsing ensures that no drops of unclean water will fall on the clean items at the end of the rinsing cycle.
- Large washing chamber is suitable for both 500x500 mm standard baskets and 600x500 mm baskets to wash 600x400 mm trays.
- Electronic control panel with temperature display to easily operate and monitor machine status.
- Equipped with drain pump for easy and quick installation without opening the machine.
- Built-in atmospheric boiler sized to raise incoming water to 84 °C minimum for sanitizing rinse. No external booster is required.
- Washing capacity of 30 baskets per hour.

Construction

- Unit to feature smooth surfaces to facilitate cleaning.
- Completely closed on the back by a cover plate.
- Large deep drawn wash tank and internal wash area with round corners and no pipes to avoid dirt built-up.
- Unit to feature rinse aid and detergent dispenser pumps.
- Large tank filter collects the soil to keep the wash water clean for a longer time and have better washing performance.
- Front panel, door, wash tank, tank filters, wash arms and rinse arms made in heavy duty anti-corrosive 304 AISI stainless steel.

Sustainability

- Insulated double skin door construction preserves heat inside the tank to lower energy consumption and the noise. Counter-balance mechanism minimizes impact when opening and closing.

APPROVAL: _____



**Warewashing
Warewashing Undercounter for
600x400mm trays, double skin, atm
boiler, 30baskets/h**

Included Accessories

- 1 of Stainless steel support for 4pcs of 600x400mm trays for pastry undercounter dishwasher PNC 867073
- 1 of Plastic rack (600x500mm) for utensils for pastry undercounter dishwasher PNC 867074

Optional Accessories

- Stainless steel support for 6pcs of 600x400mm trays for pastry undercounter dishwasher PNC 867075
- Stand for pastry undercounter dishwasher PNC 867076



**Warewashing
Warewashing Undercounter for 600x400mm trays, double skin, atm
boiler, 30baskets/h**
The company reserves the right to make modifications to the products
without prior notice. All information correct at time of printing.

Front

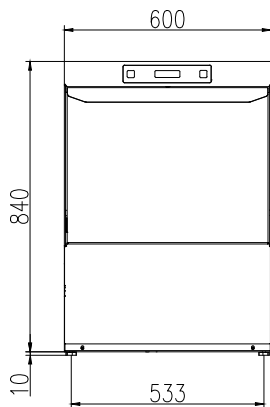

Side

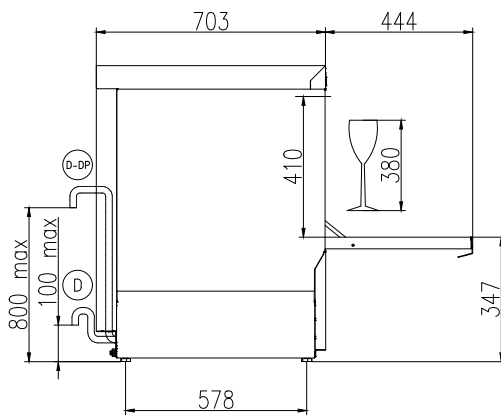

- CW11** = Cold Water inlet 1 (cleaning)
- D** = Drain
- EI** = Electrical inlet (power)
- EO** = Electrical Outlet
- HWI** = Hot water inlet
- WI** = Water inlet
- XD** = Detergent connection
- XR** = Rinse aid connection

Rear side

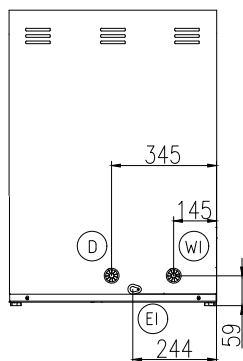

Electric

Supply voltage:	380-415 V/3N ph/50 Hz
Default Installed Power:	6.65 kW
Boiler heating elements:	6 kW
Tank heating elements:	2.4 kW
Wash pump size:	0.68 kW

Water:

Pressure, min-max:	1-6 bar
Water supply temperature*:	10-50 °C
Drain line size:	29mm
Inlet Water supply pressure:	15 - 87 psi (1 - 6 bar)
Washing tank capacity (lt):	22
Water consumption per cycle (lt):	0 / 2.2
Boiler Capacity (lt):	5.5

Key Information:

Wash temperature:	55-65°C
Cell dimensions - width:	500 mm
Cell dimensions - depth:	600 mm
Cell dimensions - height:	410 mm
Rinse temperature:	85 °C
External dimensions, Width:	600 mm
External dimensions, Depth:	703 mm
External dimensions, Height:	850 mm
Packaging size (WxDxH):	690x790x1000 mm
Baskets per hour:	30
Dishes per hour:	540
Program Cycle time:	120/180/360/540

Sustainability

Noise level:	61,3 dBA
--------------	----------