

Modular Cooking Range Line EVO700 Full Module Ambient Worktop with Drawer

ITEM # _____

MODEL # _____

NAME # _____

SIS # _____

AIA # _____



372119 (Z7WTNHN00E)

Ambient worktop with drawer,
1 module

Short Form Specification

Item No. _____

To be installed on EVO700 refrigerated/freezer bases, open base cupboards, bridging supports or cantilever systems. Exterior panels and work top in stainless steel with Scotch Brite finish. One piece pressed work top in 1.5 mm thick stainless steel. Right-angled side edges to allow flush-fitting junction between units.

Main Features

- Heavy duty internal frame in Stainless steel.
- Unit to be installed on other 700 line bases.
- Right angled side edges eliminate gaps and possible dirt traps between units.
- Suitable for countertop installation.

Construction

- One piece pressed 1.5 mm work top in Stainless steel.
- Stainless steel top provides a heavy duty work surface under any load.

Optional Accessories

- Junction sealing kit PNC 206086
- Support for bridge type installation, 800 mm PNC 206137
- Support for bridge type installation, 1000 mm PNC 206138
- Support for bridge type installation, 1200 mm PNC 206139
- Support for bridge type installation, 1400 mm PNC 206140
- Support for bridge type installation, 1600 mm PNC 206141
- Full module overshef PNC 206184
- Right and left side handrails PNC 206240
- Water column with swivel arm (water column extension not included) PNC 206289
- Water column extension PNC 206291
- 2 side covering panels, height 250 mm, depth 700 mm PNC 206320

APPROVAL: _____

Front

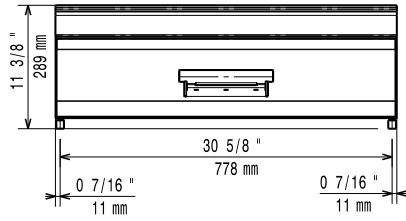

Side

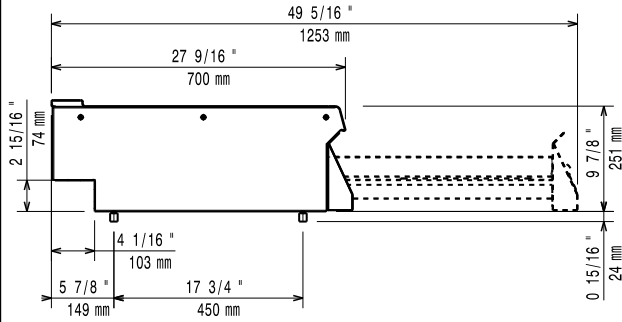

Top

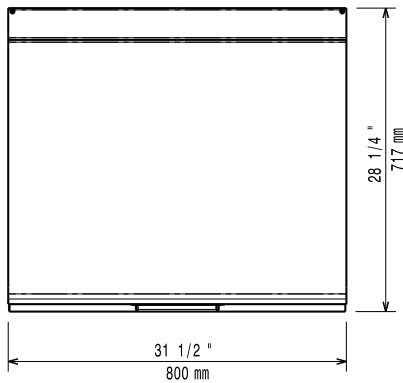

Key Information:

External dimensions, Width:	
372119 (Z7WTNHN00E)	800 mm
External dimensions, Depth:	700 mm
External dimensions, Height:	250 mm
Net weight:	25 kg