

Modular Cooking Range Line EVO700 Full Module Electric Bain Marie Top

ITEM # _____

MODEL # _____

NAME # _____

SIS # _____

AIA # _____



372145 (Z7BMEHB00N)

Electric bain-marie top with 1
GN 2/1 well

372097 (Z7BMEHB000)

Electric bain-marie top with 1
GN 2/1 well

Short Form Specification

Item No. _____

To be installed on open base installations, bridging supports or cantilever systems. Maintains cooked food at serving temperature by using hot water inside the well. Water temperature controlled by thermostat with maximum temperature of 90 °C. Exterior panels in stainless steel with Scotch Brite finish. One piece pressed work top in 1.5 mm thick stainless steel. Right-angled side edges to allow flush-fitting junction between units.

Main Features

- Unit to be mounted on open base cupboards, bridging supports or cantilever systems.
- Bain Marie used for keeping cooked food at serving temperatures using hot water.
- Incoloy armoured heating elements positioned beneath the base of the well.
- Water basin is seamlessly welded into the top of the appliance.
- Filling water level is plate-marked on the side of the well.
- Unit to feature manual refill of well.
- Water temperature controlled by thermostat with maximum temperature value of 90 °C.
- Basin drained by tap on the front of the machine.
- All major compartments located in front of unit for ease of maintenance.
- Suitable for countertop installation.

Construction

- All exterior panels in Stainless Steel with Scotch Brite finishing.
- One piece pressed 1.5 mm work top in Stainless steel.
- Model has right-angled side edges to allow flush fitting joints between units, eliminating gaps and possible dirt traps.

APPROVAL: _____

Optional Accessories

- Junction sealing kit PNC 206086
- Support for bridge type installation, 800 mm PNC 206137
- Support for bridge type installation, 1000 mm PNC 206138
- Support for bridge type installation, 1200 mm PNC 206139
- Support for bridge type installation, 1400 mm PNC 206140
- Support for bridge type installation, 1600 mm PNC 206141
- Frontal handrail 800 mm PNC 206167
- Large handrail (portioning shelf) 800 mm PNC 206186
- Frontal handrail 1200 mm PNC 206191
- Frontal handrail 1600 mm PNC 206192
- Right and left side handrails PNC 206240
- Chimney upstand, 800 mm PNC 206304
- 2 side covering panels, height 250 mm, depth 700 mm PNC 206320
- Drilled false bottom for bain-marie, 1 module PNC 921623
- Water filling tap for bain-marie top PNC 921627

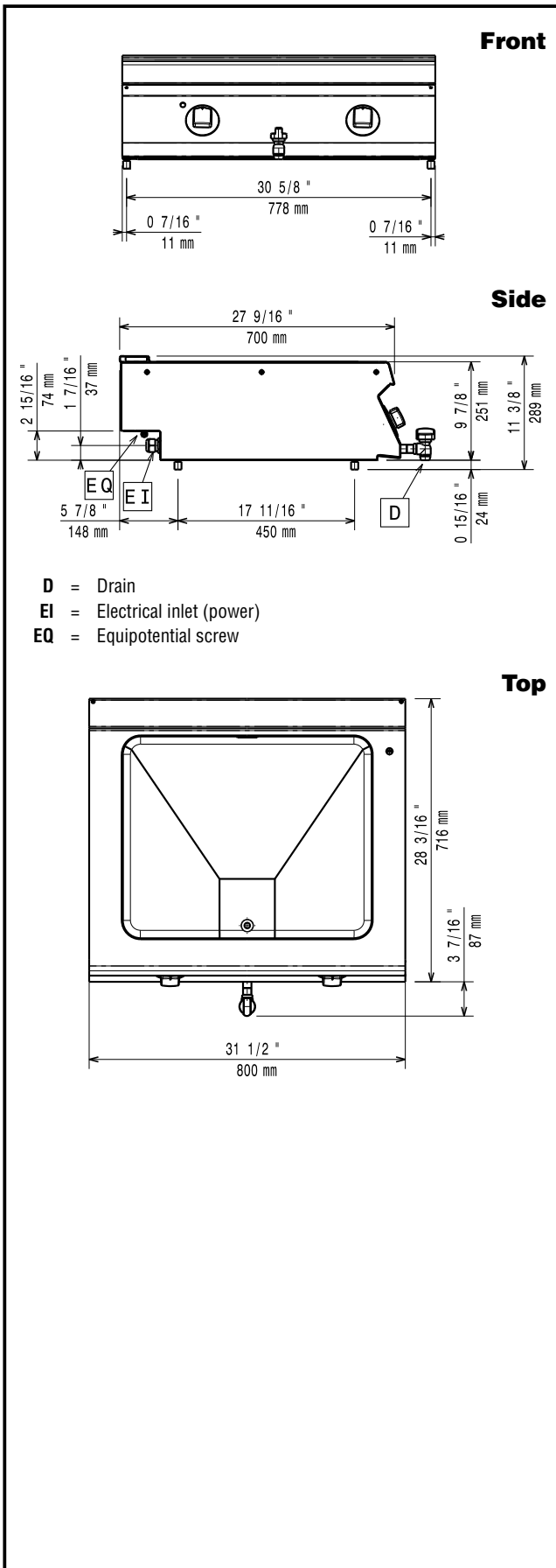

Electric

Supply voltage:	
372145 (Z7BMEHB00N)	230 V/3 ph/50/60 Hz
372097 (Z7BMEHB000)	380-400 V/2N ph/50/60 Hz
Total Watts:	3 kW
Predisposed for:	

Water:

Water Drain:	
372145 (Z7BMEHB00N)	50 mm

Key Information:

Usable well dimensions (width):	630 mm
Usable well dimensions (height):	156 mm
Usable well dimensions (depth):	510 mm
Thermostat Range:	30 °C MIN; 90 °C MAX
Net weight:	27 kg
Shipping weight:	40 kg
Shipping height:	540 mm
Shipping width:	820 mm
Shipping depth:	860 mm
Shipping volume:	0.38 m ³

If appliance is set up or next to or against temperature sensitive furniture or similar, a safety gap of approximately 150 mm should be maintained or some form of heat insulation fitted.

Certification group:

372145 (Z7BMEHB00N)	N7BE1
372097 (Z7BMEHB000)	N7BE