

Magistar Combi TS Electric Combi Oven 6GN1/1

ITEM # _____

MODEL # _____

NAME # _____

SIS # _____

AIA # _____



218720 (ZCOE61T2A0) Magistar Combi TS combi boiler oven with touch screen control, 6x1/1GN, electric, 3 cooking modes (automatic, recipe program, manual), automatic cleaning

218710 (ZCOE61T2C0) Magistar Combi TS combi boiler oven with touch screen control, 6x1/1GN, electric, 3 cooking modes (automatic, recipe program, manual), automatic cleaning

Short Form Specification

Item No.

Combi oven with high resolution full touch screen interface, multilanguage

- Built-in steam generator with real humidity control based upon Lambda Sensor
- AirFlow air distribution system to achieve maximum performance with 7 fan speed levels
- HP Automatic Cleaning: Automatic and built-in self cleaning system with integrated descale of the steam generator. 5 automatic cycles (soft, medium, strong, extra strong, rinse-only) and economizer functions to save energy, water, detergent and rinse aid
- Cooking modes: Automatic (9 food families with 100+ different pre-installed variants); Programs (a maximum of 1000 recipes can be stored and organized in 16 different categories); Manual (steam, combi and convection cycles); Specialistic Cycles (regeneration, Low Temperature Cooking, proving, EcoDelta, Sous-Vide, Static-Combi, Pasteurization of pasta, dehydration, Food Safe Control and Advanced Food Safe Control)
- Special functions: MultiTimer cooking, Cooking Optimizer to cut running costs, Make-it-Mine to customize interface, Match connection to Rapido Chiller, SoloMio to customize homepage, agenda Calendar, automatic backup mode to avoid downtime
- USB port to download HACCP data, programs and settings. Connectivity ready
- 6-point multi sensor core temperature probe
- Double glass door with LED lights
- Stainless steel construction throughout
- Supplied with n.1 tray rack 1/1 GN, 67 mm pitch.

Main Features

- Built-in steam generator for highly precise humidity and temperature control according to the chosen settings.
- Real humidity control based upon Lambda Sensor to automatically recognize quantity and size of food for consistent quality results.
- Dry, hot convection cycle (25 °C - 300 °C): ideal for low humidity cooking.
- Combination cycle (25 °C - 300 °C): combining convected heat and steam to obtain humidity controlled cooking environment, accelerating the cooking process and reducing weight loss.
- Low temperature Steam cycle (25 °C - 99 °C): ideal for sous-vide, re-thermalization and delicate cooking. Steam cycle (100 °C): seafood and vegetables. High temperature steam (25 °C - 130 °C).
- Automatic mode including 9 food families (meat, poultry, fish, vegetables, pasta/rice, eggs, savory and sweet bakery, bread, dessert) with 100+ different pre-installed variants. Through Automatic Sensing Phase the oven optimizes the cooking process according to size, quantity and type of food loaded to achieve the selected cooking result. Real time overview of the cooking parameters. Possibility to personalize and save up to 70 variants per family.
- Programs mode: a maximum of 1000 recipes can be stored in the oven's memory, to recreate the exact same recipe at any time. The recipes can be group in 16 different categories to better organize the menu. 16-step cooking programs also available.
- MultiTimer function to manage up to 20 different cooking cycles at the same time, improving flexibility and ensuring excellent cooking results. Can be saved up to 200 MultiTimer programs.
- Fan with 7 speed levels from 300 to 1500 RPM and reverse rotation for optimal evenness. Fan stops in less than 5 seconds when door is opened.
- 6-point multi sensor core temperature probe for maximum precision and food safety.
- Pictures upload for full customization of cooking cycles.
- Automatic fast cool down and pre-heat function.
- USB port to download HACCP data, share cooking programs and configurations. USB port also allows to plug-in sous-vide probe (optional accessory).
- Back-up mode with self-diagnosis is automatically activated if a failure occurs to avoid downtime.
- Special Cycles:
 - Regeneration (ideal for banqueting on plate or rethermalizing on tray),
 - Low Temperature Cooking (to minimize weight loss and maximize food quality),
 - Proving cycle,
 - EcoDelta cooking, cooking with food probe maintaining preset temperature difference between the core of the food and the cooking chamber,
 - Sous-vide cooking,
 - Static Combi (to reproduce traditional cooking from static oven),
 - Pasteurization of pasta,
 - Dehydration cycles (ideal for drying fruits,

APPROVAL:

vegetables, meats, seafood),

- Food Safe Control (to automatically monitor safety of cooking process in compliance with HACCP hygienic standards),
- Advanced Food Safe Control (to drive the cooking with pasteurization factor).
- AirFlow air distribution system to achieve maximum performance in chilling/heating evenness and temperature control thanks to a special design of the chamber combined with high precision variable speed fan.
- Grease Collector: predisposed for integrated grease drain and collection for safer operation (dedicated base as optional accessory).
- 2 different chemical options available: solid and liquid (requires optional accessory).
- Capacity: 6 GN 1/1 trays.
- OptiFlow air distribution system to achieve maximum performance in chilling/heating evenness and temperature control thanks to a special design of the chamber.

Construction

- Double thermo-glazed door with open frame construction, for cool outside door panel. Swing hinged easy-release inner glass on door for easy cleaning.
- Hygienic internal chamber with all rounded corners for easy cleaning.
- 304 AISI stainless steel construction throughout.
- Front access to control board for easy service.
- Integrated spray gun with automatic retracting system for fast rinsing.
- IPX 5 spray water protection certification for easy cleaning.
- Supplied with n.1 tray rack 1/1 GN, 67 mm pitch.
- Integrated door shield to avoid steam and heat dispersion from the door, when the roll-in rack is not used.

User Interface & Data Management

- High resolution full touch screen interface (translated in more than 30 languages) - color-blind friendly panel.
- With Match function the Oven and the Blast Chiller are connected to each other and communicate in order to guide the user through the cook&chill process optimizing time and efficiency (requires optional accessory).
- Make-it-mine feature to allow full personalization or locking of the user interface.
- Connectivity ready for real time access to connected appliances from remote and HACCP monitoring (requires optional accessory).
- Trainings and guidances supporting materials easily accessible by scanning QR-Code with any mobile device.
- Automatic consumption visualization at the end of the cycle.
- SoloMio lets the user group the favorite functions in the homepage for immediate access.
- Calendar works as an agenda where the user can plan the daily work and receive personalized alerts for each task.
- Connectivity ready for real time access to connected appliances from remote and data monitoring (requires optional accessory – contact the Company for more details).

Sustainability

- Reduced power function for customized slow cooking cycles.
- HP Automatic Cleaning: Automatic and built-in self cleaning system with integrated descale of the steam generator. 5 automatic cycles (soft, medium, strong, extra strong, rinse-only) and green functions to save energy, water, detergent and rinse aid. Also programmable with delayed start.

- Cooking Optimizer function organizes the cooking sequence of the chosen cycles optimizing the work in the kitchen from a time and energy efficiency point of view.

Optional Accessories

- | | | |
|---|------------|--------------------------|
| • External reverse osmosis filter for single tank Dishwashers with atmosphere boiler and Ovens | PNC 864388 | <input type="checkbox"/> |
| • Water softener with cartridge and flow meter (high steam usage) | PNC 920003 | <input type="checkbox"/> |
| • Water filter with cartridge and flow meter for 6 & 10 GN 1/1 ovens (low-medium steam usage - less than 2hrs per day full steam) | PNC 920004 | <input type="checkbox"/> |
| • Water softener with salt for ovens with automatic regeneration of resin | PNC 921305 | <input type="checkbox"/> |
| • Wheel kit for 6 & 10 GN 1/1 and 2/1 GN oven base (not for the disassembled one) | PNC 922003 | <input type="checkbox"/> |
| • Pair of AISI 304 stainless steel grids, GN 1/1 | PNC 922017 | <input type="checkbox"/> |
| • Pair of grids for whole chicken (8 per grid - 1,2kg each), GN 1/1 | PNC 922036 | <input type="checkbox"/> |
| • AISI 304 stainless steel grid, GN 1/1 | PNC 922062 | <input type="checkbox"/> |
| • Grid for whole chicken (4 per grid - 1,2kg each), GN 1/2 | PNC 922086 | <input type="checkbox"/> |
| • External side spray unit (needs to be mounted outside and includes support to be mounted on the oven) | PNC 922171 | <input type="checkbox"/> |
| • Baking tray for 5 baguettes in perforated aluminum with silicon coating, 400x600x38mm | PNC 922189 | <input type="checkbox"/> |
| • Baking tray with 4 edges in perforated aluminum, 400x600x20mm | PNC 922190 | <input type="checkbox"/> |
| • Baking tray with 4 edges in aluminum, 400x600x20mm | PNC 922191 | <input type="checkbox"/> |
| • Pair of frying baskets | PNC 922239 | <input type="checkbox"/> |
| • AISI 304 stainless steel bakery/pastry grid 400x600mm | PNC 922264 | <input type="checkbox"/> |
| • Double-step door opening kit | PNC 922265 | <input type="checkbox"/> |
| • Grid for whole chicken (8 per grid - 1,2kg each), GN 1/1 | PNC 922266 | <input type="checkbox"/> |
| • USB probe for sous-vide cooking | PNC 922281 | <input type="checkbox"/> |
| • Grease collection tray, GN 1/1, H=100 mm | PNC 922321 | <input type="checkbox"/> |
| • Kit universal skewer rack and 4 long skewers for GN 1/1 ovens | PNC 922324 | <input type="checkbox"/> |
| • Universal skewer rack | PNC 922326 | <input type="checkbox"/> |
| • 4 long skewers | PNC 922327 | <input type="checkbox"/> |
| • Smoker for lengthwise and crosswise oven | PNC 922338 | <input type="checkbox"/> |
| • Multipurpose hook | PNC 922348 | <input type="checkbox"/> |
| • 4 flanged feet for 6 & 10 GN , 2", 100-130mm | PNC 922351 | <input type="checkbox"/> |
| • Grid for whole duck (8 per grid - 1,8kg each), GN 1/1 | PNC 922362 | <input type="checkbox"/> |
| • Tray support for 6 & 10 GN 1/1 disassembled open base | PNC 922382 | <input type="checkbox"/> |
| • Wall mounted detergent tank holder | PNC 922386 | <input type="checkbox"/> |
| • USB single point probe | PNC 922390 | <input type="checkbox"/> |
| • IoT module for OnE Connected and Match (one IoT board per appliance - to connect oven to the blast chiller for Cook&Chill process). | PNC 922421 | <input type="checkbox"/> |

| | | | | | |
|--|------------|--------------------------|--|------------|--------------------------|
| • Tray rack with wheels, 6 GN 1/1, 65mm pitch | PNC 922600 | <input type="checkbox"/> | • Fixed tray rack for 6 GN 1/1 and 400x600mm grids | PNC 922684 | <input type="checkbox"/> |
| • Tray rack with wheels 5 GN 1/1, 80mm pitch | PNC 922606 | <input type="checkbox"/> | • Kit to fix oven to the wall | PNC 922687 | <input type="checkbox"/> |
| • Bakery/pastry tray rack with wheels holding 400x600mm grids for 6 GN 1/1 oven and blast chiller freezer, 80mm pitch (5 runners) | PNC 922607 | <input type="checkbox"/> | • 4 high adjustable feet for 6 & 10 GN ovens, 100-115MM | PNC 922688 | <input type="checkbox"/> |
| • Slide-in rack with handle for 6 & 10 GN 1/1 oven | PNC 922610 | <input type="checkbox"/> | • Tray support for 6 & 10 GN 1/1 oven base | PNC 922690 | <input type="checkbox"/> |
| • Open base with tray support for 6 & 10 GN 1/1 oven | PNC 922612 | <input type="checkbox"/> | • Detergent tank holder for open base | PNC 922699 | <input type="checkbox"/> |
| • Cupboard base with tray support for 6 & 10 GN 1/1 oven | PNC 922614 | <input type="checkbox"/> | • Bakery/pastry runners 400x600mm for 6 & 10 GN 1/1 oven base | PNC 922702 | <input type="checkbox"/> |
| • Hot cupboard base with tray support for 6 & 10 GN 1/1 oven holding GN 1/1 or 400x600mm | PNC 922615 | <input type="checkbox"/> | • Wheels for stacked ovens | PNC 922704 | <input type="checkbox"/> |
| • External connection kit for liquid detergent and rinse aid | PNC 922618 | <input type="checkbox"/> | • Mesh grilling grid, GN 1/1 | PNC 922713 | <input type="checkbox"/> |
| • Grease collection kit for GN 1/1-2/1 cupboard base (trolley with 2 tanks, open/close device for drain) | PNC 922619 | <input type="checkbox"/> | • Probe holder for liquids | PNC 922714 | <input type="checkbox"/> |
| • Stacking kit for 6+6 GN 1/1 ovens on electric 6+10 GN 1/1 GN ovens | PNC 922620 | <input type="checkbox"/> | • Odour reduction hood with fan for 6 & 10 GN 1/1 electric ovens | PNC 922718 | <input type="checkbox"/> |
| • Trolley for slide-in rack for 6 & 10 GN 1/1 oven and blast chiller freezer | PNC 922626 | <input type="checkbox"/> | • Odour reduction hood with fan for 6+6 or 6+10 GN 1/1 electric ovens | PNC 922722 | <input type="checkbox"/> |
| • Trolley for mobile rack for 2 stacked 6 GN 1/1 ovens on riser | PNC 922628 | <input type="checkbox"/> | • Condensation hood with fan for 6 & 10 GN 1/1 electric oven | PNC 922723 | <input type="checkbox"/> |
| • Trolley for mobile rack for 6 GN 1/1 on 6 or 10 GN 1/1 ovens | PNC 922630 | <input type="checkbox"/> | • Condensation hood with fan for stacking 6+6 or 6+10 GN 1/1 electric ovens | PNC 922727 | <input type="checkbox"/> |
| • Riser on feet for 2 6 GN 1/1 ovens or a 6 GN 1/1 oven on base | PNC 922632 | <input type="checkbox"/> | • Exhaust hood with fan for 6 & 10 GN 1/1 ovens | PNC 922728 | <input type="checkbox"/> |
| • Riser on wheels for stacked 2x6 GN 1/1 ovens, height 250mm | PNC 922635 | <input type="checkbox"/> | • Exhaust hood with fan for stacking 6+6 or 6+10 GN 1/1 ovens | PNC 922732 | <input type="checkbox"/> |
| • Stainless steel drain kit for 6 & 10 GN oven, dia=50mm | PNC 922636 | <input type="checkbox"/> | • Exhaust hood without fan for 6&10 1/1GN ovens | PNC 922733 | <input type="checkbox"/> |
| • Plastic drain kit for 6 & 10 GN oven, dia=50mm | PNC 922637 | <input type="checkbox"/> | • Exhaust hood without fan for stacking 6+6 or 6+10 GN 1/1 ovens | PNC 922737 | <input type="checkbox"/> |
| • Trolley with 2 tanks for grease collection | PNC 922638 | <input type="checkbox"/> | • Fixed tray rack, 5 GN 1/1, 85mm pitch | PNC 922740 | <input type="checkbox"/> |
| • Grease collection kit for GN 1/1-2/1 open base (2 tanks, open/close device for drain) | PNC 922639 | <input type="checkbox"/> | • 4 high adjustable feet for 6 & 10 GN ovens, 230-290mm | PNC 922745 | <input type="checkbox"/> |
| • Wall support for 6 GN 1/1 oven | PNC 922643 | <input type="checkbox"/> | • Tray for traditional static cooking, H=100mm | PNC 922746 | <input type="checkbox"/> |
| • Dehydration tray, GN 1/1, H=20mm | PNC 922651 | <input type="checkbox"/> | • Double-face griddle, one side ribbed and one side smooth, 400x600mm | PNC 922747 | <input type="checkbox"/> |
| • Flat dehydration tray, GN 1/1 | PNC 922652 | <input type="checkbox"/> | • Trolley for grease collection kit | PNC 922752 | <input type="checkbox"/> |
| • Open base for 6 & 10 GN 1/1 oven, disassembled - NO accessory can be fitted with the exception of 922382 | PNC 922653 | <input type="checkbox"/> | • Water inlet pressure reducer | PNC 922773 | <input type="checkbox"/> |
| • Bakery/pastry rack kit for 6 GN 1/1 oven with 5 racks 400x600mm and 80mm pitch | PNC 922655 | <input type="checkbox"/> | • Kit for installation of electric power peak management system for 6 GN and 10 GN ovens | PNC 922774 | <input type="checkbox"/> |
| • Stacking kit for 6 GN 1/1 combi oven on 15&25kg blast chiller/freezer crosswise | PNC 922657 | <input type="checkbox"/> | • Extension for condensation tube, 37cm | PNC 922776 | <input type="checkbox"/> |
| • Heat shield for stacked ovens 6 GN 1/1 on 6 GN 1/1 | PNC 922660 | <input type="checkbox"/> | • Non-stick universal pan, GN 1/1, H=20mm | PNC 925000 | <input type="checkbox"/> |
| • Heat shield for stacked ovens 6 GN 1/1 on 10 GN 1/1 | PNC 922661 | <input type="checkbox"/> | • Non-stick universal pan, GN 1/1, H=40mm | PNC 925001 | <input type="checkbox"/> |
| • Heat shield for 6 GN 1/1 oven | PNC 922662 | <input type="checkbox"/> | • Non-stick universal pan, GN 1/1, H=60mm | PNC 925002 | <input type="checkbox"/> |
| • Compatibility kit for installation of 6 GN 1/1 electric oven on previous 6 GN 1/1 electric oven (old stacking kit 922319 is also needed) | PNC 922679 | <input type="checkbox"/> | • Double-face griddle, one side ribbed and one side smooth, GN 1/1 | PNC 925003 | <input type="checkbox"/> |
| | | | • Aluminum grill, GN 1/1 | PNC 925004 | <input type="checkbox"/> |
| | | | • Frying pan for 8 eggs, pancakes, hamburgers, GN 1/1 | PNC 925005 | <input type="checkbox"/> |
| | | | • Flat baking tray with 2 edges, GN 1/1 | PNC 925006 | <input type="checkbox"/> |
| | | | • Baking tray for 4 baguettes, GN 1/1 | PNC 925007 | <input type="checkbox"/> |
| | | | • Potato baker for 28 potatoes, GN 1/1 | PNC 925008 | <input type="checkbox"/> |
| | | | • Non-stick universal pan, GN 1/2, H=20mm | PNC 925009 | <input type="checkbox"/> |
| | | | • Non-stick universal pan, GN 1/2, H=40mm | PNC 925010 | <input type="checkbox"/> |
| | | | • Non-stick universal pan, GN 1/2, H=60mm | PNC 925011 | <input type="checkbox"/> |
| | | | • Compatibility kit for installation on previous base GN 1/1 | PNC 930217 | <input type="checkbox"/> |

Front

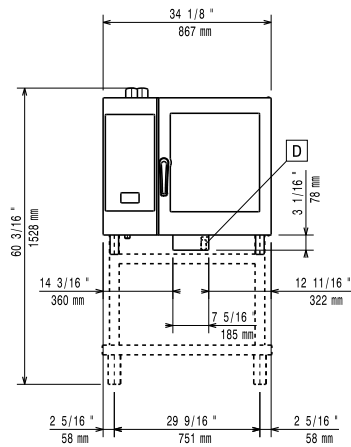

Side

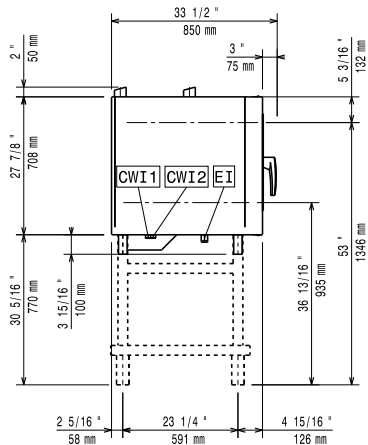

- C-** = Cold Water inlet 1 (cleaning)
- WI-1**
- C-** = Cold Water Inlet 2 (steam generator)
- WI-2**
- D** = Drain
- DO** = Overflow drain pipe
- EI** = Electrical inlet (power)

Top

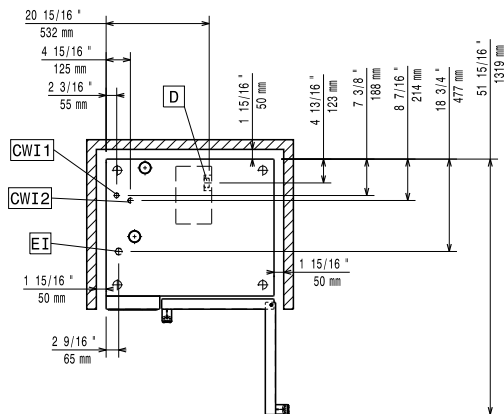

Electric

Supply voltage:

- 218720 (ZCOE61T2A0)** 380-415 V/3N ph/50-60 Hz
- 218710 (ZCOE61T2C0)** 220-240 V/3 ph/50-60 Hz

Electrical power, default:

11.1 kW

Electrical power max.:

11.8 kW

Circuit breaker required

Water:

Water inlet connections

"CWI1-CWI2": 3/4"

Pressure, bar min/max: 1-6 bar

Drain "D": 50mm

Max inlet water supply temperature: 30 °C

Chlorides: <17 ppm

Conductivity: >50 µS/cm

Electrolux Professional recommends the use of treated water, based on testing of specific water conditions.

Please refer to user manual for detailed water quality information.

Installation:

Clearance:

Clearance: 5 cm rear and right hand sides.

Suggested clearance for service access:

50 cm left hand side.

Capacity:

Trays type:

6 - 1/1 Gastronorm

Max load capacity:

30 kg

Key Information:

Door hinges:

External dimensions, Width: 867 mm

External dimensions, Depth: 775 mm

External dimensions, Height: 808 mm

Net weight: 117 kg

Shipping weight: 134 kg

Shipping height: 1030 mm

Shipping width: 930 mm

Shipping depth: 930 mm

Shipping volume: 0.89 m³