

Magistar Combi DS Electric Combi Oven 6GN1/1

ITEM # _____

MODEL # _____

NAME # _____

SIS # _____

AIA # _____



218810 (ZCOE61B2C0) Magistar Combi DS combi boiler oven with digital control, 6x1/1GN, electric, programmable, automatic cleaning

218820 (ZCOE61B2A0) Magistar Combi DS combi boiler oven with digital control, 6x1/1GN, electric, programmable, automatic cleaning

Short Form Specification

Item No.

- Combi oven with digital interface with guided selection.
- Built-in steam generator with real humidity control based upon Lambda Sensor.
 - AirFlow air distribution system to achieve maximum performance with 5 fan speed levels.
 - HP Automatic Cleaning: Automatic and built-in self cleaning system with integrated descale of the steam generator. 5 automatic cycles (soft, medium, strong, extra strong, rinse-only).
 - Cooking modes: Programs (a maximum of 100 recipes can be stored); Manual (steam, combi and convection cycles); EcoDelta cooking cycle; Regeneration cycle.
 - Automatic backup mode to avoid downtime.
 - USB port to download HACCP data, programs and settings. Connectivity ready.
 - Single sensor core temperature probe.
 - Double-glass door with LED lights.
 - Stainless steel construction throughout.
 - Supplied with n.1 tray rack 1/1 GN, 67 mm pitch.

Main Features

- Built-in steam generator for highly precise humidity and temperature control according to the chosen settings.
- Real humidity control based upon Lambda Sensor to automatically recognize quantity and size of food for consistent quality results.
- Dry, hot convection cycle (25 °C - 300 °C): ideal for low humidity cooking.
- Combination cycle (25 °C - 300 °C): combining convected heat and steam to obtain humidity controlled cooking environment, accelerating the cooking process and reducing weight loss.
- Low temperature Steam cycle (25 °C - 99 °C): ideal for sous-vide, re-thermalization and delicate cooking. Steam cycle (100 °C): seafood and vegetables. High temperature steam (101 °C - 130 °C).
- EcoDelta cooking: cooking with food probe maintaining preset temperature difference between the core of the food and the cooking chamber.
- Pre-set program for Regeneration, ideal for banqueting on plate or rethermalizing on tray.
- Programs mode: a maximum of 100 recipes can be stored in the oven's memory, to recreate the exact same recipe at any time. 4-step cooking programs also available.
- AirFlow air distribution system to achieve maximum performance in chilling/heating evenness and temperature control thanks to a special design of the chamber combined with high precision variable speed fan.
- Fan with 5 speed levels from 300 to 1500 RPM and reverse rotation for optimal evenness. Fan stops in less than 5 seconds when door is opened.
- Single sensor core temperature probe included.
- Automatic fast cool down and pre-heat function.
- HP Automatic Cleaning: Automatic and built-in self cleaning system with integrated descale of the steam generator. 5 automatic cycles (soft, medium, strong, extra strong, rinse-only).
- Grease Collector: predisposed for integrated grease drain and collection for safer operation (dedicated base as optional accessory).
- Back-up mode with self-diagnosis is automatically activated if a failure occurs to avoid downtime.
- 2 different chemical options available: solid and liquid (requires optional accessory).
- Capacity: 6 GN 1/1 trays.
- OptiFlow air distribution system to achieve maximum performance in chilling/heating evenness and temperature control thanks to a special design of the chamber.

Construction

- Double thermo-glazed door with open frame construction, for cool outside door panel. Swing hinged easy-release inner glass on door for easy cleaning.
- Hygienic internal chamber with all rounded corners for easy cleaning.
- 304 AISI stainless steel construction throughout.

APPROVAL: _____

- Front access to control board for easy service.
- IPX5 spray water protection certification for easy cleaning.
- Supplied with n.1 tray rack 1/1 GN, 67 mm pitch.
- Integrated door shield to avoid steam and heat dispersion from the door, when the roll-in rack is not used.

User Interface & Data Management

- Digital interface with LED backlight buttons with guided selection.
- USB port to download HACCP data, share cooking programs and configurations. USB port also allows to plug-in sous-vide probe (optional accessory).
- Connectivity ready for real time access to connected appliances from remote and HACCP monitoring (requires optional accessory).

Sustainability

- Reduced power function for customized slow cooking cycles.

Front

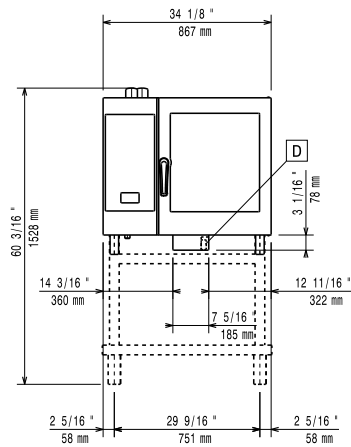

Side

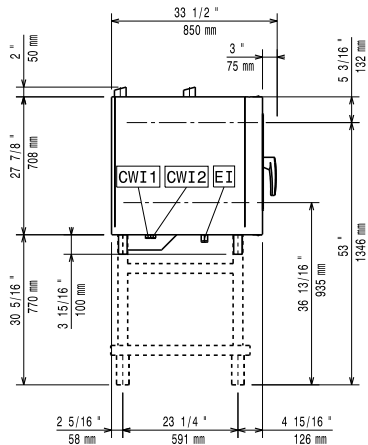

- C-** = Cold Water inlet 1 (cleaning)
- WI-1**
- C-** = Cold Water Inlet 2 (steam generator)
- WI-2**
- D** = Drain
- DO** = Overflow drain pipe
- EI** = Electrical inlet (power)

Top

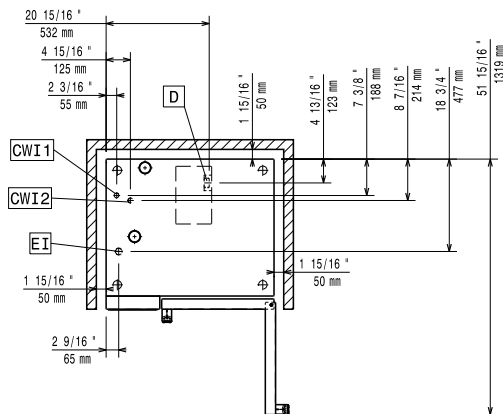

Electric

Circuit breaker required

Supply voltage:

- 218810 (ZCOE61B2C0)** 220-240 V/3 ph/50-60 Hz
- 218820 (ZCOE61B2A0)** 380-415 V/3N ph/50-60 Hz

Electrical power, max:

11.8 kW

Electrical power, default:

11.1 kW

Water:

Inlet water temperature, max:

30 °C

Inlet water pipe size (CWI1, CWI2):

3/4"

Pressure, min-max:

1-6 bar

Chlorides:

<45 ppm

Conductivity:

>50 µS/cm

Drain "D":

50mm

Electrolux Professional recommends the use of treated water, based on testing of specific water conditions.

Please refer to user manual for detailed water quality information.

Installation:

Clearance:

Clearance: 5 cm rear and right hand sides.

Suggested clearance for service access:

50 cm left hand side.

Capacity:

Trays type:

6 (GN 1/1)

Max load capacity:

30 kg

Key Information:

Door hinges:

Right Side

External dimensions, Width:

867 mm

External dimensions, Depth:

775 mm

External dimensions, Height:

808 mm

Weight:

131 kg

Net weight:

114 kg

Shipping weight:

131 kg

Shipping volume:

218810 (ZCOE61B2C0) 0.84 m³

218820 (ZCOE61B2A0) 0.85 m³