

**229758 (ECOIE102T3A3L)**

SkyLine PremiumS Combi Boiler Oven with touch screen control, 10x2/1GN, electric, 3 cooking modes (automatic, recipe program, manual), automatic cleaning, boiler in AISI 316L, left-hinged 3-glass door

Main Features

- 6-point multi sensor core temperature probe for maximum precision and food safety.
- Programs mode: a maximum of 1000 recipes can be stored in the oven's memory, to recreate the exact same recipe at any time. The recipes can be grouped in 16 different categories to better organize the menu. 16-step cooking programs also available.
- Dry, hot convection cycle (25 °C - 300 °C): ideal for low humidity cooking.
- Combination cycle (25 °C - 300 °C): combining convected heat and steam to obtain humidity controlled cooking environment, accelerating the cooking process and reducing weight loss.
- Low temperature Steam cycle (25 °C - 99 °C): ideal for sous-vide, re-thermalization and delicate cooking.
Steam cycle (100 °C): seafood and vegetables.
High temperature steam (101 °C - 130 °C).
- Built-in steam generator for highly precise humidity and temperature control according to the chosen settings.
- Real humidity control based upon Lambda Sensor to automatically recognize quantity and size of food for consistent quality results.
- Fan with 7 speed levels from 300 to 1500 RPM and reverse rotation for optimal evenness. Fan stops in less than 5 seconds when door is opened.
- Automatic fast cool down and pre-heat function.
- MultiTimer function to manage up to 60 different cooking cycles at the same time, improving flexibility and ensuring excellent cooking results. Can be saved up to 200 MultiTimer programs.
- Automatic mode including 9 food families (meat, poultry, fish, vegetables, pasta/rice, eggs, savory and sweet bakery, bread, dessert) with 100+ different pre-installed variants. Through Automatic Sensing Phase the oven optimizes the cooking process according to size, quantity and type of food loaded to achieve the selected cooking result. Real time overview of the cooking parameters. Possibility to personalize and save up to 70 variants per family.
- Cycles :
 - Regeneration (ideal for banqueting on plate or rethermalizing on tray),
 - Low Temperature Cooking (to minimize weight loss and maximize food quality) Patented US7750272B2 and related family,
 - Proving cycle,
 - EcoDelta cooking, cooking with food probe maintaining preset temperature difference between the core of the food and the cooking chamber,
 - Sous-vide cooking,
 - Static Combi (to reproduce traditional cooking from static oven),
 - Pasteurization of pasta,
 - Dehydration cycle (ideal for drying fruits, vegetables, meats, seafood),
 - Food Safe Control (to automatically monitor safety of cooking process in compliance with HACCP hygienic standards) Patented US6818865B2 and related family,
 - Advanced Food Safe Control (to drive the cooking with pasteurization factor).
- Back-up mode with self-diagnosis is automatically activated if a failure occurs to avoid downtime.
- OptiFlow air distribution system to achieve maximum performance in chilling/heating evenness and temperature control thanks to a special design of the chamber.



- GreaseOut: integrated grease drain and collection kit (to use the kit, the oven must be ordered as special code).
- Electrolux Professional recommends the use of treated water to guarantee optimal cooking results and extend the life of the appliance. Check local water condition to select the appropriate water filter. More info available on the website.
- SkyClean: Automatic and built-in self cleaning system with 4 automatic cycles (short, medium, intensive, rinse) and integrated descale of the steam generator.
- Short cleaning cycle: optimized cleaning cycle with a duration of just 33 minutes, improving efficiency and reducing downtime.

Construction

- 304 AISI stainless steel construction throughout
- IPX5 spray water protection certification for easy cleaning.
- Hygienic internal chamber with all rounded corners for easy cleaning.
- Boiler in 316L AISI to protect against corrosion.
- Integrated spray gun with automatic retracting system for fast rinsing.
- Triple thermo-glazed door with 2 hinged inside panels for easy cleaning and double LED lights line.
- Front access to control board for easy service.

User Interface & Data Management

- Pictures upload for full customization of cooking cycles.
- Trainings and guidances supporting materials easily accessible by scanning QR-Code with any mobile device.
- Make-it-mine feature to allow full personalization or locking of the user interface.
- With SkyDuo the Oven and the Blast Chiller are connected to each other and communicate in order to guide the user through the cook&chill process optimizing time and efficiency (requires optional accessory).
- SkyHub lets the user group the favorite functions in the homepage for immediate access.
- MyPlanner works as an agenda where the user can plan the daily work and receive personalized alerts for each task.
- USB port to download HACCP data, share cooking programs and configurations. USB port also allows to plug-in sous-vide probe (optional accessory).
- High resolution full touch screen interface (translated in more than 30 languages) - color-blind friendly panel.
- Automatic consumption visualization at the end of the cycle.
- Connectivity for remote real time access, easy HACCP management, equipment uptime increase, consumption tracking and energy management (requires optional accessory).





A focus on sustainability

Sustainability

- Energy Star 2.0 certified product
- Reduced power function for customized slow cooking cycles.
- Plan-n-Save function organizes the cooking sequence of the chosen cycles optimizing the work in the kitchen from a time and energy efficiency point of view.
- Wing-shaped handle with ergonomic design and hands-free opening with the elbow, making managing trays simpler. Protected by registered design (EM003143551 and related family).
- Zero Waste provides chefs with useful tips for minimizing food waste. Zero Waste is a library of Automatic recipes that aims to: - give a second life to raw food close to expiration date (e.g., from milk to yogurt) - obtain genuine and tasty dishes from overripe fruit/vegetables (usually considered not appropriate for sale) - promote the use of typically discarded food items (e.g., carrot peels).
- Save energy, water, detergent and rinse aid with SkyClean green functions.
- C22 and C25 detergents are formulated without phosphates and phosphorus (C25 is also maleic acid-free), making them safe for both the environment and human health.
- The outer cardboard packaging is made from 70% recycled materials and FSC*-certified paper, printed with eco-friendly, water-based ink to support sustainability and environmental responsibility. (*Forest Stewardship Council is the world's leading organization for sustainable forest management).
- Triple-glass door minimize your energy loss.* * Approx. -10% of idle energy consumption in convection based on test in compliance with ASTM Standard F2861-20

Certifications & Recognitions



Product assessed by the manufacturer and deemed to meet EU safety, health, and environmental protection requirements.



International system for mutual acceptance of test reports and certificates concerning the safety of electrical and electronic components, equipment, and products.



Certification for **energy efficiency**, ensuring products meet strict standards for reducing energy consumption, saving money, and helping protect the environment.



Product acceptable for use in a commercial food establishment and meets applicable construction, performance, and material requirements.



Awarded for its ease of use and smooth ergonomic design, it confirms its human-centered approach.



UL Verification is an independent, science-based process that validates marketing claims, helping distinguish verified facts from fiction.



Find out more:
ISO Certificates
[Electrolux Professional Recognitions](#)

The company reserves the right to make modifications to the products without prior notice. All information correct at time of printing.

2026/05/24

3/9

Technical specifications

Electric

Supply voltage:	380-415 V/3N ph/50-60 Hz
Electrical power max.:	40.1 kW
Electrical power, default:	37.4 kW

Water:

Max inlet water supply temperature:	30 °C
Chlorides:	<85 ppm
Conductivity:	>50 µS/cm
Drain "D":	50mm
Water inlet connections "CW11-CW12":	3/4"
Pressure, bar min/max:	1-6 bar

Capacity:

Trays type:	10 - GN 2/1
Max load capacity:	100 kg

Key Information:

External dimensions, Width:	1090 mm
External dimensions, Depth:	971 mm
Weight:	188 kg
External dimensions, Height:	1058 mm
Net weight:	188 kg
Shipping weight (gross):	210 kg
Shipping volume:	1.62 m ³

ISO Certificates

ISO Standards:	ISO 9001; ISO 14001; ISO 45001; ISO 50001
----------------	---

Installation drawings

Front

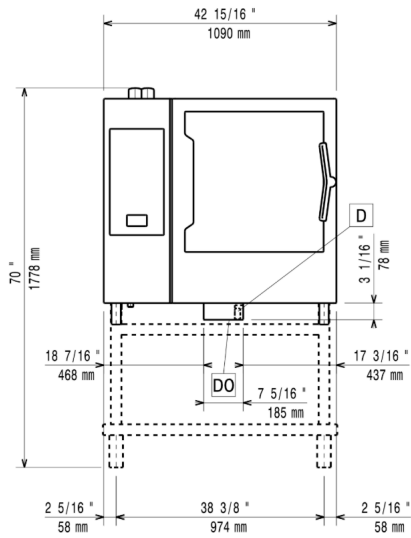

Side

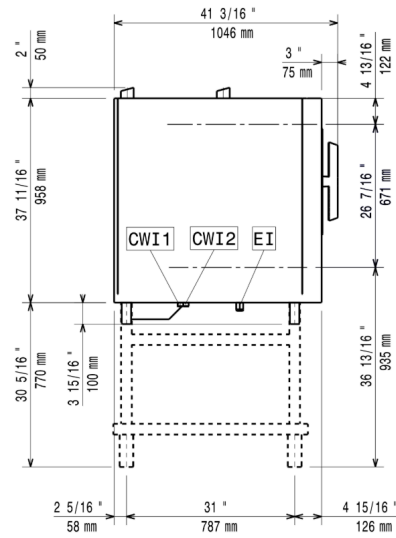

Top

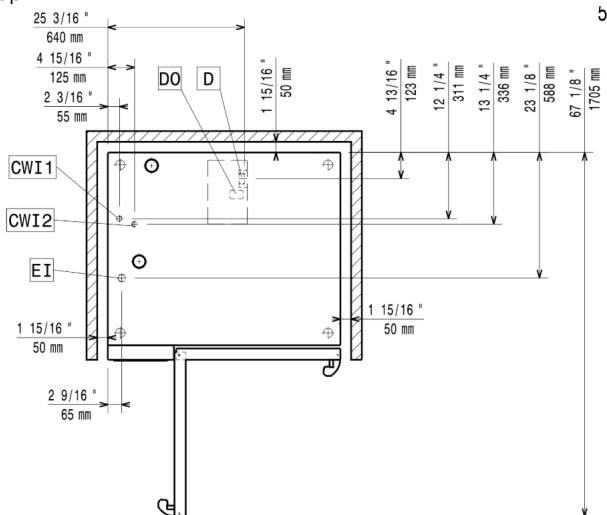

CWI1 = Cold Water inlet 1 (cleaning)

EI = Electrical inlet (power)

D = Drain

DO = Overflow drain pipe

Accessories

Optional Accessories

PNC Code	Description
Bases & base accessories	
922384	Tray support for 6 & 10 GN 2/1 disassembled open base
922613	Open base with tray support for 6 & 10 GN 2/1 oven
922616	Cupboard base with tray support for 6 & 10 GN 2/1 oven
922654	Open base for 6 & 10 GN 2/1 oven, disassembled - NO accessory can be fitted with the exception of 922384
922692	Tray support for 6 & 10 GN 2/1 oven base
Cleaning solutions	
922386	Wall mounted detergent tank holder
922618	External connection kit for liquid detergent and rinse aid
922699	Detergent tank holder for open base
Containers, trays and grids	
922017	Pair of AISI 304 stainless steel grids, GN 1/1
922036	Pair of grids for whole chicken (8 per grid - 1,2kg each), GN 1/1
922062	AISI 304 stainless steel grid, GN 1/1
922076	AISI 304 stainless steel grid, GN 2/1
922175	Pair of AISI 304 stainless steel grids, GN 2/1
922189	Baking tray for 5 baguettes in perforated aluminum with silicon coating, 400x600x38mm
922190	Baking tray with 4 edges in perforated aluminum, 400x600x20mm
922191	Baking tray with 4 edges in aluminum, 400x600x20mm
922239	Pair of frying baskets
922264	AISI 304 stainless steel bakery/pastry grid 400x600mm
922266	Grid for whole chicken (8 per grid - 1,2kg each), GN 1/1
922325	Kit universal skewer rack and 6 short skewers for Lengthwise and Crosswise ovens
922348	Multipurpose hook
922362	Grid for whole duck (8 per grid - 1,8kg each), GN 1/1
922651	Dehydration tray, GN 1/1, H=20mm
922652	Flat dehydration tray, GN 1/1
922713	Mesh grilling grid, GN 1/1
922746	Tray for traditional static cooking, H=100mm
922747	Double-face griddle, one side ribbed and one side smooth, 400x600mm
925000	Non-stick universal pan, GN 1/1, H=20mm
925001	Non-stick universal pan, GN 1/1, H=40mm
925002	Non-stick universal pan, GN 1/1, H=60mm
925003	Double-face griddle, one side ribbed and one side smooth, GN 1/1
925004	Aluminum grill, GN 1/1
925005	Frying pan for 8 eggs, pancakes, hamburgers, GN 1/1

Accessories

PNC Code	Description
Containers, trays and grids	
925006	Flat baking tray with 2 edges, GN 1/1
925008	Potato baker for 28 potatoes, GN 1/1
925012	Kit of 6 non-stick universal pans, GN 1/1, H=20mm
925013	Kit of 6 non-stick universal pans, GN 1/1, H=40mm
925014	Kit of 6 non-stick universal pan GN 1/1, H=60mm
Doors and drawers	
922265	Double-step door opening kit
Drains	
922636	Stainless steel drain kit for 6 & 10 GN oven, dia=50mm
922637	Plastic drain kit for 6 & 10 GN oven, dia=50mm
Feet, wheels and ramps	
922003	Wheel kit for 6 & 10 GN 1/1 and 2/1 GN oven base (not for the disassembled one)
922351	4 flanged feet for 6 & 10 GN , 2", 100-130mm
922688	4 adjustable feet for 6 & 10 GN ovens, 100-115mm
922693	4 adjustable feet with black cover for 6 & 10 GN ovens, 100-115mm
922745	4 high adjustable feet for 6 & 10 GN ovens, 230-290mm
Food probes	
922281	USB probe for sous-vide cooking
922390	USB single point probe
922714	Probe holder for liquids
Grease/oil management	
922357	Grease collection tray, GN 2/1, H=60 mm
922752	Trolley for grease collection kit
Handling - bakery	
922609	Bakery/pastry tray rack with wheels 400x600mm for 10 GN 2/1 oven and blast chiller freezer, 80mm pitch (8 runners)
Handling - banqueting	
922366	Thermal cover for 10 GN 2/1 oven and blast chiller freezer
922650	Banquet rack with wheels holding 51 plates for 10 GN 2/1 oven and blast chiller freezer, 75mm pitch
Handling - gastronom	
922603	Tray rack with wheels 10 GN 2/1, 65mm pitch
922604	Tray rack with wheels, 8 GN 2/1, 80mm pitch
922627	Trolley for slide-in rack for 10 GN 2/1 oven and blast chiller freezer
Installation solutions	
922664	Heat shield for 10 GN 2/1 oven
922667	Heat shield-stacked for ovens 6 GN 2/1 on 10 GN 2/1
922774	Kit for installation of electric power peak management system for 6 & 10 GN Oven

Accessories

PNC Code	Description
Slide-in supports	
922605	Slide-in rack with handle for 6 & 10 GN 2/1 oven
Spray units	
922171	External side spray unit (needs to be mounted outside and includes support to be mounted on the oven)
Stacking kits	
922621	Stacking kit for 6 GN 2/1 oven placed on electric 10 GN 2/1 oven
922631	Trolley for mobile rack for 6 GN 2/1 on 6 or 10 GN 2/1 ovens
Ventilation	
922440	Steam optimizer
922719	Odour reduction hood with fan for 6 & 10 GN 2/1 electric ovens
922721	Odour reduction hood with fan for 6+6 or 6+10 GN 2/1 electric ovens
922724	Condensation hood with fan for 6 & 10 GN 2/1 electric oven
922726	Condensation hood with fan for stacking 6+6 or 6+10 GN 2/1 electric ovens
922729	Exhaust hood with fan for 6 & 10 GN 2/1 GN ovens
922731	Exhaust hood with fan for stacking 6+6 or 6+10 GN 2/1 ovens
922734	Exhaust hood without fan for 6&10x2/1 GN oven
922736	Exhaust hood without fan for stacking 6+6 or 6+10 GN 2/1 ovens
922751	Hood Hopper to directly connect the Hood to the centralized ventilation system, for Standard Hoods (with fan motor) and Hoods without fan motor
922776	Extension for condensation tube, 37cm
Wall mounting kits	
922687	Kit to fix oven to the wall
Water treatment	
864388	External reverse osmosis filter for single tank Dishwashers with atmosphere boiler and Ovens
920003	Water filter with cartridge and flow meter for high steam usage (combi used mainly in steaming mode)
920005	Water filter with cartridge and flow meter for medium steam usage
Other accessories	
922326	Universal skewer rack
922328	6 short skewers
922421	IoT module for OnE Connected (Combi Ovens, Blast chiller/freezers, Rack Type DW) and SkyDuo (one IoT board per appliance - to connect oven to blast chiller for Cook&Chill process).
922435	Connectivity router (WiFi and LAN)
922448	Baking tray with 4 edges in perforated aluminum, coated surface, 400x600x20mm
922449	Baking tray with 4 edges in aluminum, coated surface, 400x600x20mm
922451	Grease collection kit for GN 1/1-2/1 open base (2 tanks, open/close device for drain)
922452	Grease collection kit for ovens GN 1/1 & 2/1 (2 plastic tanks, connection valve with pipe for drain)
922773	Water inlet pressure reducer

Accessories

Recommended Detergents

PNC Code	Description
0S2394	C25 Rinse & Descale Tabs, phosphate-free, phosphorous-free, maleic acid-free, 50 tabs bucket
0S2395	C22 Cleaning Tabs, phosphate-free, phosphorous-free, 100 bags bucket