

**260813 (EFCG61CSAS)**

Convection Oven Crosswise 6x1/1GN, gas

Main Features

- Drip tray to collect residual cooking juices and fat.
- Maximum temperature of 300°C.
- Food temperature probe (available as accessory).
- Rapid cooling of oven cavity.
- Halogen lighting and "crosswise" pan supports allow clear and unobstructed view of the products being cooked.
- Main switch/Cooking mode selector which can be used to set: ON/OFF, hot air without humidification and hot air with humidification (choice of 5 different humidity levels).
- Timer to set the cooking time, adjustable up to 120 minutes or for continuous operation with an acoustic alarm to show the cycle has finished. At the end of the set cooking time the heat and the fan are automatically switched off.
- Perfect evenness: guarantees perfect distribution of heat throughout the oven cavity.
- Capacity: 6 GN 1/1 trays.
- Drip tray under the door to collect condensed liquid available as accessory.

Construction

- Double thermo-glazed door with open frame construction, for cool outside door panel. Swing hinged easy-release inner glass on door for easy cleaning.
- IPx4 water protection.
- Integrated drain outlet.
- 1 pair of 60 mm pitch runners is supplied as standard.
- Robust structure thanks to stainless steel construction.
- Ergonomic door handle.
- Cooking chamber in 430 AISI stainless steel.



Optional Accessories

PNC Code	Description
Bases & base accessories	
922101	Open base for 6 GN 1/1 convection oven
922105	Shelf guides for 6x1/1GN, ovens base
Containers, trays and grids	
921101	Pair of AISI 304 stainless steel grids, GN 1/1
922017	Pair of AISI 304 stainless steel grids, GN 1/1
922036	Pair of grids for whole chicken (8 per grid - 1,2kg each), GN 1/1
922062	AISI 304 stainless steel grid, GN 1/1
922239	Pair of frying baskets
922266	Grid for whole chicken (8 per grid - 1,2kg each), GN 1/1
922325	Kit universal skewer rack and 6 short skewers for Lengthwise and Crosswise ovens
922713	Mesh grilling grid, GN 1/1
925000	Non-stick universal pan, GN 1/1, H=20mm
925001	Non-stick universal pan, GN 1/1, H=40mm
925002	Non-stick universal pan, GN 1/1, H=60mm
925003	Double-face griddle, one side ribbed and one side smooth, GN 1/1
925004	Aluminum grill, GN 1/1
925005	Frying pan for 8 eggs, pancakes, hamburgers, GN 1/1
Food probes	
921702	Probe for ovens 6 and 10x1/1GN
Grease/oil management	
922177	Fat filter for 6x1/1GN
Handling - gastronorm	
921713	Guide kit for 1/1GN drain pan
Other accessories	
922338	Volcano Smoker for lengthwise and crosswise oven
Spray units	
922170	Retractable hose reel spray unit
922171	External side spray unit (needs to be mounted outside and includes support to be mounted on the oven)
Stacking kits	
922657	Stacking kit for 6 GN 1/1 combi or convection oven on 15&25kg blast chiller/freezer crosswise
Ventilation	
921701	Flue condenser for gas ovens 10x1/1-2/1
Other accessories	
921106	Support for 1/2GN pan (2pcs)
922326	Universal skewer rack
922328	6 short skewers



Recommended Detergents

PNC Code	Description
OS2282	EXTRA STRONG DETERGENT FOR OVEN C20-2pzx5L
OS2283	EXTRA STRONG RINSE AID C21-2pzx5L



Technical specifications

Electric

Supply voltage:	220-230 V/1 ph/50 Hz
Electrical power max.:	0.35 kW
Capacity:	
Trays type:	6 - GN 1/1
Key Information:	
External dimensions, Width:	860 mm
External dimensions, Depth:	767 mm
External dimensions, Height:	701 mm
Net weight:	92.1 kg
Functional level:	
Cooking cycles - air-convection:	300 °C
Heating-up time (hot air cycle):	215°C / 350s.

ISO Certificates

ISO Standards:	ISO 9001; ISO 14001; ISO 45001; ISO 50001
----------------	---

Front

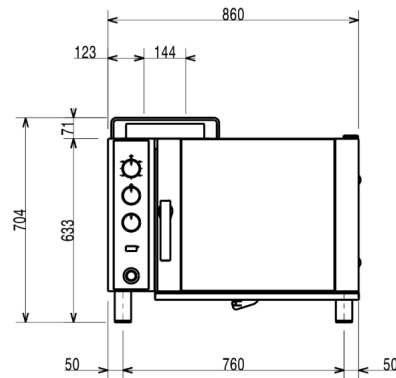

Side

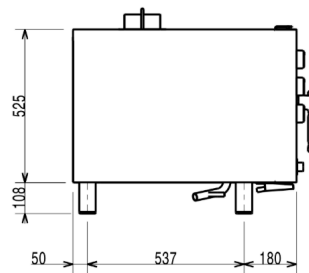

Top

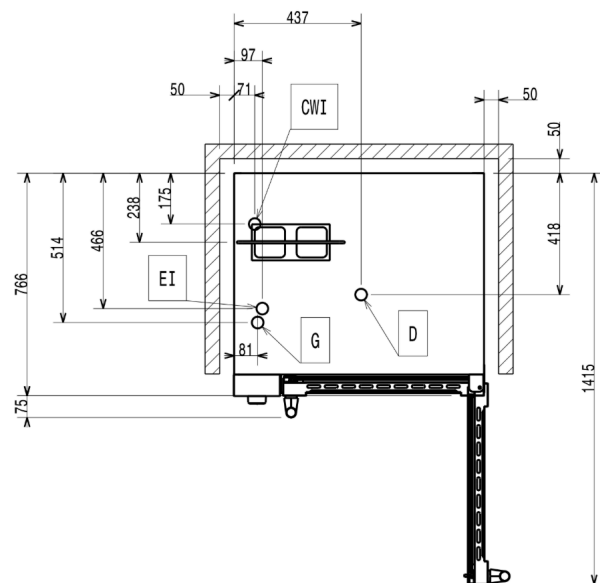

CWII = Cold Water inlet 1 (cleaning)

D = Drain

G = Gas connection

EI = Electrical inlet (power)

DO = Overflow drain pipe



Find out more:
ISO Certificates
Electrolux Professional Recognitions

The company reserves the right to make modifications to the products without prior notice. All information correct at time of printing.

2026/06/01

4/4